



BACK-UP ALARMS



DF445 only



DF445 only



40 SERIES Grommet Mount

The 40 series back-up alarms utilize a standard 4.5" rear-lighting grommet for mounting directly into the vehicle body. Vehicle down time is reduced since the alarm can be fitted or replaced quickly and easily without the use of tools; there are no holes to drill and no bolts to tighten. Not only is the 'in-body' mounting method easier to install, it also ensures the warning signal is projected where it is needed, directly into the hazard zone at the rear of the vehicle.

ECCO's Smart Alarm models measure ambient noise and adjust their sound level, creating a volume that is safe without being annoying or contributing to noise pollution. Smart Alarms eliminate the need for constant manual adjustment and help prevent intentional alarm disconnection.

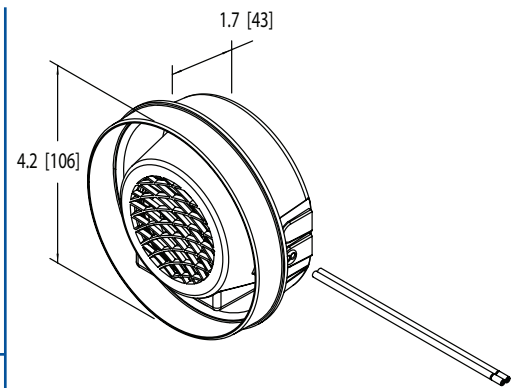

Models

PART NO.	TYPE	dB(A)	AMPS
SA955	Smart	82-102	0.4
DF445	Dual-Function	102 Back-up & Dual-Tone	0.5
4050	Tonal	102	0.4
4030	Tonal	97	0.2

Alarm Specifications

Connection: 16 AWG blunt cut wires
 Housing: Fiberglass reinforced nylon
 Mounting: 4.5" standard rear lighting grommet

Features and Benefits

- 12-24 VDC
- Grommet mount reduces installation time, requiring no tools
- Directs warning to rear of vehicle
- For use with standard 4.5" rear lighting grommet (order separately)
- Temperature Range: -40°F to +185°F (-40°C to +85°C)

Parts & Accessories

- Mounting Grommet: R2140GR

