



# Installation and Operation Instructions

## Auto Adjust 87-112 dB(A), 112 dB(A) Warble 12-24 Volt Back-Up Alarm

**IMPORTANT!** Read all instructions before installing and using. Installer: This manual must be delivered to the end user.



### WARNING!

Failure to install or use this product according to manufacturer's recommendations may result in property damage, serious injury, and/or death to those you are seeking to protect!

 **Do not install and/or operate this safety product unless you have read and understood the safety information contained in this manual.**

1. Proper installation combined with operator training in the use, care, and maintenance of emergency warning devices are essential to ensure the safety of emergency personnel and the public.
2. Emergency warning devices often require high electrical voltages and/or currents. Exercise caution when working with live electrical connections.
3. This product must be properly grounded. Inadequate grounding and/or shorting of electrical connections can cause high current arcing, which can cause personal injury and/or severe vehicle damage, including fire.
4. Proper placement and installation is vital to the performance of this warning device. Install this product so that output performance of the system is maximized and the controls are placed within convenient reach of the operator so that they can operate the system without losing eye contact with the roadway.
5. Do not install this product or route any wires in the deployment area of an air bag. Equipment mounted or located in an air bag deployment area may reduce the effectiveness of the air bag or become a projectile that could cause serious personal injury or death. Refer to the vehicle owner's manual for the air bag deployment area. It is the responsibility of the user/operator to determine a suitable mounting location ensuring the safety of all passengers inside the vehicle particularly avoiding areas of potential head impact.
6. It is the responsibility of the vehicle operator to ensure daily that all features of this product work correctly. In use, the vehicle operator should ensure the projection of the warning signal is not blocked by vehicle components (i.e., open trunks or compartment doors), people, vehicles or other obstructions.
7. The use of this or any other warning device does not ensure all drivers can or will observe or react to an emergency warning signal. Never take the right-of-way for granted. It is the vehicle operator's responsibility to be sure they can proceed safely before entering an intersection, drive against traffic, respond at a high rate of speed, or walk on or around traffic lanes.
8. This equipment is intended for use by authorized personnel only. The user is responsible for understanding and obeying all laws regarding emergency warning devices. Therefore, the user should check all applicable city, state, and federal laws and regulations. The manufacturer assumes no liability for any loss resulting from the use of this warning device.

Selection and installation of an alarm should meet the requirements of local and regional governing bodies such as ISO, SAE, etc. Install an alarm that will be audible on the noisiest job site the vehicle will be used on. Ground guidance should be provided to clear backing vehicles when the audibility of the alarm is in question. When installing an alarm product, be sure to verify that both sides of the mounting surface are clear of anything that could be damaged. Place the back-up alarm so it will operate properly under adverse conditions. The location must provide protection from impact and poor weather conditions while allowing unobstructed sound projection to the target hazard area. Do NOT mount the alarm opening facing up.

The back-up alarm system must be inspected each workday at the beginning of each shift to ensure that it is audible, operating properly, and securely attached to the vehicle. Inspect more often when: 1) The vehicle is operating in an adverse environment; 2) The vehicle is operating in foul weather conditions; 3) The operator has reason to believe the alarm has been damaged or is not working properly; and/or 4) Increased background noise interferes with the ability of workers to recognize when the alarm is sounding.

**Note: The back-up alarm should be used for REVERSING WARNING applications only. The alarm sound is generally recognized as a warning for reversing vehicles/mobile equipment. Alarm products with different sound tones are available for non-reversing applications.**

## Installation and Sound Level

This product is designed to concentrate its audible alarm in the target hazard area. **NOTE:** This product is a safety device. It **must** be connected to the vehicle's fused back-up lamp circuit or its own separate fused power point to assure its continued operation. For proper sound dispersion, it must be mounted approximately 4 feet above ground level with the sound opening facing the target hazard area. The label on each alarm describes the sound output level in decibels dB(A).

1. Select a mounting location at the rear of the vehicle that will provide protection from flying objects, debris, and foul weather conditions while allowing unobstructed sound projection from the vehicle. Do **NOT** mount the alarm opening facing up.
2. See figure 1. Using the alarm housing as a template, scribe drill position marks through the mounting holes in the unit. Drill holes at the position marks. Recommended drill bit size- Q bit.
3. Secure the unit on the vehicle with a minimum of four user-supplied 5/16" bolts and locknuts, or bolts, lockwashers, and nuts.

4. This unit requires a reliable power and ground connection for operation. Complete the wiring according to the wiring diagram in Figure 1. Use 18 gauge wire (minimum) Figure 1A if vehicle back-up light circuit is used, or Figure 1B if a user installed switch is required, and observe correct polarity. **WARNING!!** Anytime the back-up alarm is in operation, continuity must be maintained between the positive voltage of the power source and the positive terminal of the back-up alarm as well as between the negative terminal of the back-up alarm and the common ground (the vehicle member to which all wire grounds are connected). During operation the voltage differential between the positive voltage of the power source and the positive terminal (+) of the back-up alarm shall not exceed 150mV. During operation the voltage differential between the common ground and the negative terminal (-) of the alarm shall not exceed 150mV. Route wire in a protected manner in accordance with vehicle manufacturer recommendations. **NOTE:** The back-up alarm will not operate when its power connections are reversed and is protected against reversed polarity up to 400V.

**IMPORTANT! DO NOT spray any coating material, e.g. paint, undercoating, etc., over the sound opening. DO NOT install the alarm or its wiring in proximity to ignition wires. Failure to observe these conditions may have an adverse effect on the alarm's performance.**

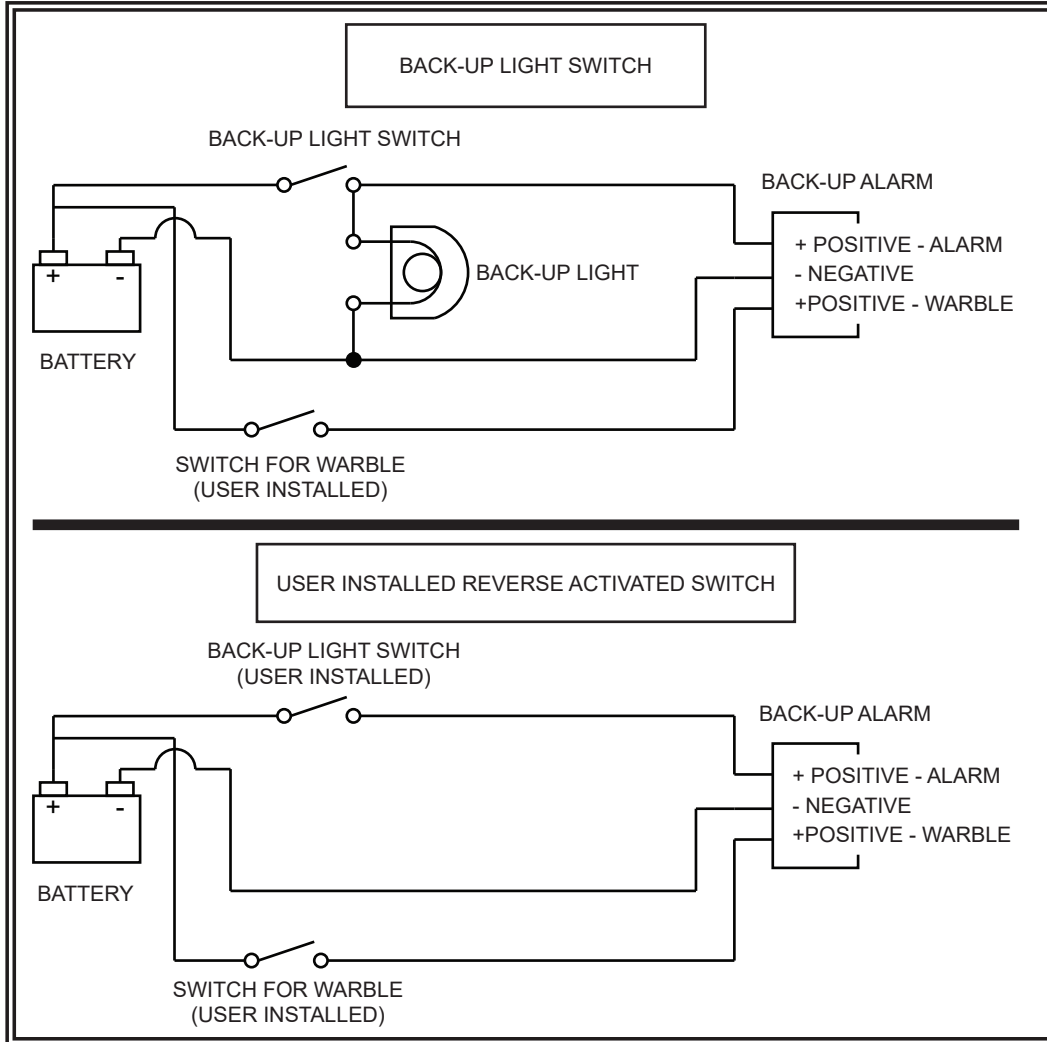

5. Test the alarm for proper operation. If alarm does not sound, review Step 4. After confirming proper operation, affix the provided Warning Label to the dashboard of the vehicle in plain view of the operator. **Do not operate this vehicle if the back-up alarm is not functioning properly.**
6. Add requirement to "test back-up alarm system before operating vehicle" to the daily maintenance log and notify your supervisor or team leader that people operating this vehicle **MUST** confirm proper alarm operation at the beginning of each work shift. **Do not operate this vehicle if the back-up alarm is not functioning properly.**

## Specifications

A listing of product specifications is available upon request.

## Vehicle Operations

As the operator of a vehicle, you should always know when the alarm is sounding and when it is not sounding. Should the alarm become inoperative, discontinue vehicle operation and notify your supervisor or team leader. Operating a vehicle with an alarm that is not functioning properly could endanger the lives and/or property of those who depend on the alarm signal for safety.

Back-up alarm testing must be itemized on the daily maintenance log. An alarm on an operating vehicle must be tested prior to the vehicle's use at the beginning of each work shift. Check the daily maintenance log to confirm acceptable results of this testing before operating the vehicle/mobile equipment.

- More frequent testing may be necessary if the vehicle is operating in adverse conditions.

- Ground guidance should be provided to the driver when backing a vehicle in a job environment where the audibility of the alarm is in question.

## Maintenance

Preventive maintenance procedures must specify an alarm safety system inspection. This check should include a thorough examination of the electrical connections and the sound opening. The sound opening must be kept clear of dust, mud, or any other foreign material that may prevent the alarm from sounding properly. Should this inspection reveal an alarm that is not functioning properly, place a "Do Not Use" sign on the equipment and notify your supervisor or team leader.

### **Manufacturer Limited Warranty and Limitation of Liability:**

**Manufacturer warrants that on the date of purchase, this product will conform to Manufacturer's specifications for this product (which are available from the Manufacturer upon request). This Limited Warranty extends for twenty-four (24) months from the date of purchase.**

**DAMAGE TO PARTS OR PRODUCTS RESULTING FROM TAMPERING, ACCIDENT, ABUSE, MISUSE, NEGLIGENCE, UNAPPROVED MODIFICATIONS, FIRE OR OTHER HAZARD; IMPROPER INSTALLATION OR OPERATION; OR NOT BEING MAINTAINED IN ACCORDANCE WITH THE MAINTENANCE PROCEDURES SET FORTH IN MANUFACTURER'S INSTALLATION AND OPERATING INSTRUCTIONS VOIDS THIS LIMITED WARRANTY.**

### **Exclusion of Other Warranties:**

**MANUFACTURER MAKES NO OTHER WARRANTIES, EXPRESSED OR IMPLIED. THE IMPLIED WARRANTIES FOR MERCHANTABILITY, QUALITY OR FITNESS FOR A PARTICULAR PURPOSE, OR ARISING FROM A COURSE OF DEALING, USAGE OR TRADE PRACTICE ARE HEREBY EXCLUDED AND SHALL NOT APPLY TO THE PRODUCT AND ARE HEREBY DISCLAIMED, EXCEPT TO THE EXTENT PROHIBITED BY APPLICABLE LAW. ORAL STATEMENTS OR REPRESENTATIONS ABOUT THE PRODUCT DO NOT CONSTITUTE WARRANTIES.**

### **Remedies and Limitation of Liability:**

**MANUFACTURER'S SOLE LIABILITY AND BUYER'S EXCLUSIVE REMEDY IN CONTRACT, TORT (INCLUDING NEGLIGENCE), OR UNDER ANY OTHER THEORY AGAINST MANUFACTURER REGARDING THE PRODUCT AND ITS USE SHALL BE, AT MANUFACTURER'S DISCRETION, THE REPLACEMENT OR REPAIR OF THE PRODUCT, OR THE REFUND OF THE PURCHASE PRICE PAID BY BUYER FOR NON-CONFORMING PRODUCT. IN NO EVENT SHALL MANUFACTURER'S LIABILITY ARISING OUT OF THIS LIMITED WARRANTY OR ANY OTHER CLAIM RELATED TO THE MANUFACTURER'S PRODUCTS EXCEED THE AMOUNT PAID FOR THE PRODUCT BY BUYER AT THE TIME OF THE ORIGINAL PURCHASE. IN NO EVENT SHALL MANUFACTURER BE LIABLE FOR LOST PROFITS, THE COST OF SUBSTITUTE EQUIPMENT OR LABOR, PROPERTY DAMAGE, OR OTHER SPECIAL, CONSEQUENTIAL, OR INCIDENTAL DAMAGES BASED UPON ANY CLAIM FOR BREACH OF CONTRACT, IMPROPER INSTALLATION, NEGLIGENCE, OR OTHER CLAIM, EVEN IF MANUFACTURER OR A MANUFACTURER'S REPRESENTATIVE HAS BEEN ADVISED OF THE POSSIBILITY OF SUCH DAMAGES. MANUFACTURER SHALL HAVE NO FURTHER OBLIGATION OR LIABILITY WITH RESPECT TO THE PRODUCT OR ITS SALE, OPERATION AND USE, AND MANUFACTURER NEITHER ASSUMES NOR AUTHORIZES THE ASSUMPTION OF ANY OTHER OBLIGATION OR LIABILITY IN CONNECTION WITH SUCH PRODUCT.**

**This Limited Warranty defines specific legal rights. You may have other legal rights which vary from jurisdiction to jurisdiction. Some jurisdictions do not allow the exclusion or limitation of incidental or consequential damages.**



833 West Diamond St, Boise, Idaho 83705

**Customer Service** USA 800-635-5900

UK +44 (0)113 237 5340 | AUS +61 (0)3 63322444

**ECCOESG.com**

An ECCO SAFETY GROUP™ Brand

**ECCOSAFETYGROUP.com**