

REVISION HISTORY		
REV.	DESCRIPTION	DATE
03	REVISED PER EL0216	2021-07-16
A	INITIAL RELEASE PER EL0216	2021-07-21
B	REVISED PER EL0216	2021-08-24

SPECIFICATIONS

- CERTIFICATIONS: ECE R10; SAE J595 (MAR 2014) (SEE CHART); J845 (FEB 2019) CLASS 1S; CA Title 13 (SEE CHART) ; ; Reg 65 (SEE CHART); IP67/IP69K
 Note: Unique components, accessories, and hardware kits are not typically included in the Product Certification Test Protocols. Unless otherwise Specified, the Product Certifications referred to herein are predicated upon the base product model configuration.
- FLASH MODE: SINGLE : 75 ± 5 FLASHES PER MINUTE
 SINGLE : 120 ± 5 FLASHES PER MINUTE
 DOUBLE : 75 ± 5 FLASHES PER MINUTE
- VOLTAGE (NOMINAL): 12-24 VDC
- VOLTAGE (EXTREME): 9.0-32 VDC
- CURRENT (PEAK): SEE CHART (@ 12 VDC NOMINAL)
- POWER (MAXIMUM): SEE CHART (@ 12 VDC NOMINAL)
- TEMPERATURE RANGE: -40°F (-40°C) TO 149°F (65°C)
- CONNECTION: 4 - 22 AWG CABLE
- MOUNTING: 2 BOLT
- BASE MATERIAL: ALUMINUM
- LENS MATERIAL: POLYCARBONATE
- PRODUCT WEIGHT: 0.12 LBS (0.05 Kg)

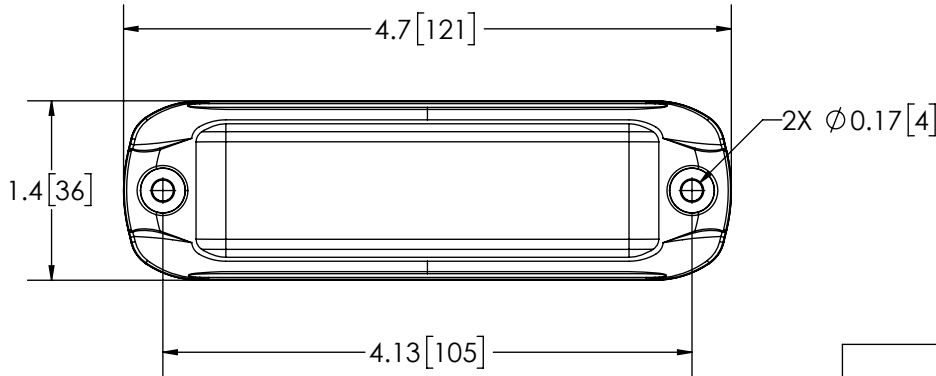
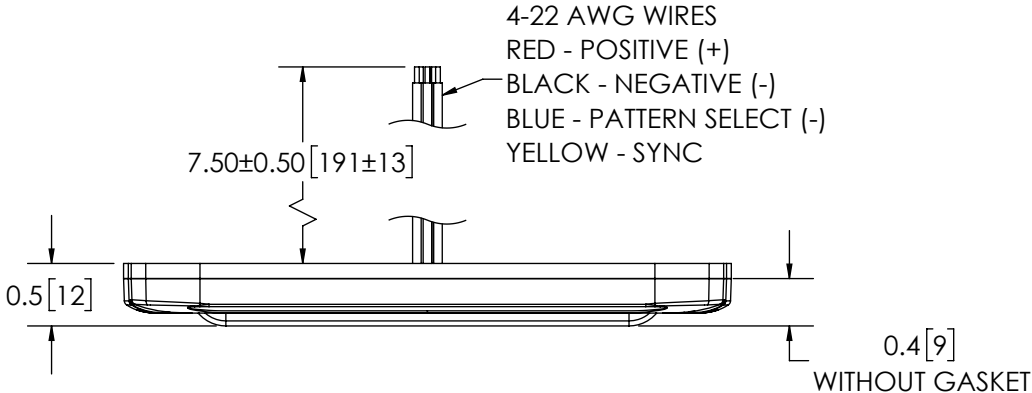

FGS. PRODUCT CHART

FGS. NO.	COLOR	CURRENT (PEAK) A	POWER (MAX) W	SAE J595	TITLE 13	ECE R65
ED3801A	AMBER	0.68	8.7	CLASS 1	CLASS B	CLASS 1
ED3801B	BLUE	0.76	12.2	CLASS 1	CLASS B	CLASS 1
ED3801G	GREEN	0.82	12.8	-	-	-
ED3801R	RED	0.79	9.6	CLASS 1	CLASS B	CLASS 1
ED3801W	WHITE	0.74	12.4	CLASS 1	-	-

NOTES:
 1. DIMENSIONS IN INCHES[MILLIMETERS (FOR REFERENCE)]

PROPRIETARY AND CONFIDENTIAL INFORMATION

THIS DRAWING AND THE DESIGN AND OTHER INFORMATION DISCLOSED HEREIN ARE THE PROPERTY OF ELECTRONIC CONTROLS COMPANY AND/OR ITS ECCO SAFETY GROUP AFFILIATES ("ECCO") AND IS ISSUED IN CONFIDENCE TO RECIPIENT FOR ENGINEERING INFORMATION PURPOSES ONLY. THIS DRAWING AND THE DESIGN AND OTHER INFORMATION DISCLOSED HEREIN MAY NOT BE USED, COPIED, REPRODUCED OR OTHERWISE DISCLOSED IN PART OR IN WHOLE TO THIRD PARTIES OR USED FOR ANY OTHER PURPOSE WITHOUT PRIOR ECCO WRITTEN CONSENT. ECCO RESERVES ALL PATENT, COPYRIGHT, TRADEMARK AND OTHER PROPRIETARY RIGHTS TO THIS DOCUMENT, INCLUDING ALL DESIGN, MANUFACTURING, REPRODUCTION, USE AND SALES RIGHTS THERETO. THIS DRAWING IS SUBJECT TO RECALL BY ECCO AT ANY TIME, AND YOUR POSSESSION AND/OR USE CONSTITUTES ACCEPTANCE OF THESE TERMS. ©2021 ELECTRONIC CONTROLS COMPANY

SCALE 2:3	APPROVALS	DATE
CAD GENERATED DRAWING DO NOT MANUALLY UPDATE. MODEL REFERENCED: 01	DRAWN BY JW	2021-08-18
	CHECKED BTK	2021-08-19
TOLERANCES ARE IN INCHES, AND MILLIMETERS TOLERANCES UNLESS OTHERWISE STATED ARE:	MECH. ENG.	
MILLIMETERS DECIMALS XX. ± 1.0mm XX.X ± 0.5mm	ELEC. ENG.	
INCHES DECIMALS X.X ± 0.1 X.XX ± 0.04 X.XXX ± 0.02	TEST ENG.	
ANGLES ± 0.5°	SALES	
FRACTIONS ± 1/64		
THIRD ANGLE PROJECTION		

ECCO www.eccolink.com

Americas (800) 635-5900 | Europe +44 (0)113 237 5340 | Asia Pacific +61 (0)3 63322444

6 LED, THIN MNT, 12-24V

CUSTOMER PART NO.
SEE CHART

SIZE: A DWG. NO. ED3801X REV. B

Electronically Controlled Use Latest Copy SHEET 1 OF 1 Project: EL0216 Date Created: 2021-07-09