

Catalog No. DS245
Weatherly No. 090
2023
Supersedes No. DS245 2017



THE DRIVELINE EXPERTS

2023

Proven Quality Drivelines



Manufacturing Driveline Solutions®
in the USA Since 1921.

NeapcoAftermarket.com

©Neapco LLC 2023

IMPORTANT INFORMATION

Issue Date 2023
Weatherly No. 090
Catalog DS245

Please read the following important information before using this Catalog:

ALWAYS CONSULT AND REVIEW THE ORIGINAL MANUFACTURERS INSTRUCTION MANUAL(S) TO DETERMINE THE APPROPRIATE INSTALLATION PROCEDURES FOR A PARTICULAR VEHICLE APPLICATION.

FOR THE LATEST INFORMATION ALWAYS REFER TO NeapcoParts.com

IMPORTANT NOTICE

The data listed in this catalog is correct to the best of our knowledge, having been compiled from sources of information which we believe to be reliable. However, we cannot assume any responsibility for possible error. Parts included in this catalog are manufactured for use only in the intended O.E.M. vehicle application(s). Installation and use in a vehicle that has been modified to any degree that is not consistent and equivalent to O.E.M. production specifications for the vehicle application(s) may result in reduced life or possible part failure.

WARRANTY

We warrant to the original purchaser all new parts to be free of defects in material and workmanship for a period of 24 months when such parts are used on applications which have been approved by our Engineering Department, but not against damage caused by negligence or abuse.

Our obligations and liabilities under this Warranty shall be limited to replacing or repairing such parts if found upon inspection by us to be defective.

OUR WARRANTIES ARE STRICTLY LIMITED TO THOSE JUST STATED. WARRANTIES OF MERCHANTABILITY OR FITNESS FOR A PARTICULAR PURPOSE AND ALL IMPLIED WARRANTIES ARISING FROM A COURSE OF DEALING, USAGE OR TRADE, BY STATUTE OR OTHERWISE ARE HEREBY DISCLAIMED, and in the event of breach of any warranty or any legal action brought by buyer based on alleged negligence or other tortious conduct of us, buyer's sole and exclusive remedy will be replacement of defective material as stated above. WE WILL NOT BE LIABLE FOR INCIDENTAL, CONSEQUENTIAL OR CONTINGENT DAMAGES OF ANY KIND. We make no warranty whatsoever with respect to component parts or accessories not supplied by us.

TABLE OF CONTENTS

Section	Section Name	Sub Section	Page
1	Companion Flange	Standard Flange	1-2
		Large Flange	1-5
		Flange Adapter	1-7
2	Flange Yoke	Inside Lock-Up	2-2
		Outside Lock-Up	2-3
		Bearing Plate Construction	2-5
		C.V. Flange Adapter	2-6
		C.V. Outside Lock-Up	2-7
		C.V. Inside Lock-Up	2-8
		Torque Limiter	2-8
3	Slip Yoke	Transmission Flange Sleeve	3-2
		Sleeve	3-2
		PTO Sleeve	3-3
		PTO Hex Bore - Inside Lock-Up	3-4
		PTO Square Bore - Inside Lock-Up	3-4
		PTO Rectangular Bore - Inside Lock-Up	3-5
		PTO Round Bore - Inside Lock-Up	3-5
		Splined Slip Yoke - Inside Lock-Up	3-6
		Splined Slip Yoke - Outside Lock-Up	3-7
		Transmission Inside Lock-Up	3-9
		Transmission Outside Lock-Up	3-10
		Bearing Plate Construction	3-12
		Splined - Inside Lock-Up	3-13

TABLE OF CONTENTS

Section	Section Name	Sub Section	Page
4	End Yoke	PTO hex bore - inside lock-up	4-2
		PTO square bore - inside lock-up	4-3
		PTO rectangular bore - inside lock-up	4-5
		PTO round bore - inside lock-up	4-6
		PTO round bore - outside lock-up	4-11
		PTO round bore - u-bolt	4-14
		PTO round bore - weld yoke	4-14
		PTO splined bore - inside lock-up	4-15
		PTO splined bore - outside lock-up	4-18
		PTO inner tube profile	4-24
		PTO outer tube profile	4-25
		Driveshaft splined - inside lock-up	4-26
		Driveshaft splined - outside lock-up	4-27
		Splined - C.V. construction	4-28
		Splined - u-bolt construction	4-29
		Splined - bearing strap construction	4-30
		Splined - bearing plate construction	4-33
		Splined - wing RPL construction	4-35
		Splined - steering clamp construction	4-36
		Splined - wing bearing construct	4-36

TABLE OF CONTENTS

Section	Section Name	Sub Section	Page
5	Center & Tube Weld Yoke	C.V. Ball Stud Tube Weld Yoke - Inside Lock-up	5-2
		C.V. Ball Stud Tube Weld Yoke - Outside Lock-up	5-2
		C.V. Ball Stud Tube Weld Yoke - Extended Lube	5-4
		C.V. Centering Yoke	5-5
		C.V.H Yoke - Inside Lock-up	5-5
		C.V.H Yoke - Outside Lock-up	5-6
		Double Pivot Yoke	5-6
		Tube Weld Yoke (Steel) - Inside Lock-up	5-7
		Tube Weld Yoke (Steel) - Outside Lock-up	5-8
		PTO Tube Weld Yoke (Steel) - Inside Lock-up	5-10
		PTO Tube Weld Yoke (Steel) - Outside Lock-up	5-10
		Bearing Plate Construction	5-11
		PlateLock Construction	5-12
		6	Shafting / Tubing / Yoke & Tube Assembly
Aux/PTO Solid Shaft-Rectangular	6-2		
Aux/PTO Solid Shaft-Square	6-3		
Aux/PTO Solid Shaft-Hexagonal	6-3		
Aux/PTO Solid Shaft-Spilned	6-4		
Aux/PTO Shaft Tubing-Round	6-4		
Aux/PTO Tubing-Rectangular	6-5		

TABLE OF CONTENTS

Section	Section Name	Sub Section	Page
		Drive Shaft Tubing - Steel	6-5
		Yoke & Tube Assembly	6-10
		PTO Tubing	6-10
		PTO Yoke and U-Joint Assembly	6-12
		PTO Yoke and Tube Assembly	6-16
7	Stub Shaft	CV Flange Stub	7-2
		Splined Mid-Ship - Outboard Slip Yokes	7-2
		Mid-Ship Cap Screw & Shaft Nut Type	7-4
		Slip Stub Shaft	7-5
		PTO Stub Shaft	7-8
8	Yoke Shaft	Outside Lock-Up	8-2
		Bearing Plate Construction	8-3
		PlateLock Construction	8-4
		Double Pivot Yoke Extended	8-5
9	Driveshaft & Double Cardan C.V.	Double Cardan C.V. Ball Seat Repair Kit	9-2
		Double Cardan C.V. Head Assembly	9-3
		PTO / AUX Shaft	9-6
		Drive Shaft-Steel	9-16
		UTV Drive Shafts	9-20
		CV Axle Assembly	9-21
		Drive Shaft Repair Kit	9-22
		Driveshaft Kit	9-23
		Steering Shaft Assembly	9-23
		PTO / AUX Shaft-Shielding System	9-24

TABLE OF CONTENTS

Section	Section Name	Sub Section	Page
10	Small Parts	Driveline Weight	10-2
		Neapco Ultra-Performance Universal Joint Grease	10-2
		PTO Friction Disc	10-3
		PTO Safety Shield Kit	10-4
		Slip Yoke-Stub Shaft Assembly (Includes U-Joint)	10-5
		Drive Shaft Sleeve	10-6
		Increasing Bushing	10-6
		Pilot Reducer	10-7
		Dust Seal	10-7
		Welch Plug	10-9
		U-Bolt Kit	10-9
		U-Joint Bearing Cap Retainer	10-10
		Bearing Strap Kit	10-11
		Bolt	10-13
		Snap Ring	10-13
		Drive Shaft Boot	10-15
		Washer	10-16
		Ball Seal	10-16
		Shaft Nut	10-16
		Lube Fitting	10-17
		Multi Purpose Retaining Ring	10-17

TABLE OF CONTENTS

Section	Section Name	Sub Section	Page
		U-Joint Fastener Bolt Kit	10-17
		Drive Shaft Centering Tool	10-17
		Strap	10-18
		Hardware Kit	10-18
		PTO Yoke & Shaft Alignment Key	10-18
		PTO Tube Pin	10-19
		PTO Repair Kit	10-19
		PTO Collar	10-20
		PTO Friction Clutch	10-20
11	Center Support	Dimensional Listing by Bearing ID	11-2
12	Aluminium Components	Balance Weights	12-2
		Tubing	12-3
		Driveshaft Assemblies	12-4
		Tube Yokes	12-4
		Yoke Shaft Assemblies	12-6
13	Wing Bearing Driveline Products	End Yoke	13-2
		Slip Yoke	13-2
		Stub Shaft	13-3
		Driveshaft Stub Shaft	13-4
		Tube Weld Yoke	13-5
		Yoke Shaft	13-7

TABLE OF CONTENTS

Section	Section Name	Sub Section	Page
14	General Information	Universal Joints	14-3
		Driveline Components	14-4
		Driveline Fabrication	14-12
		Aluminum Components	14-20
		PTO Components	14-22
		Trouble Shooting Guide	14-25
		Glossary	14-27



Off-Road / ATV / UTV



Commercial Vehicle



Industrial



Off-Highway-Ag

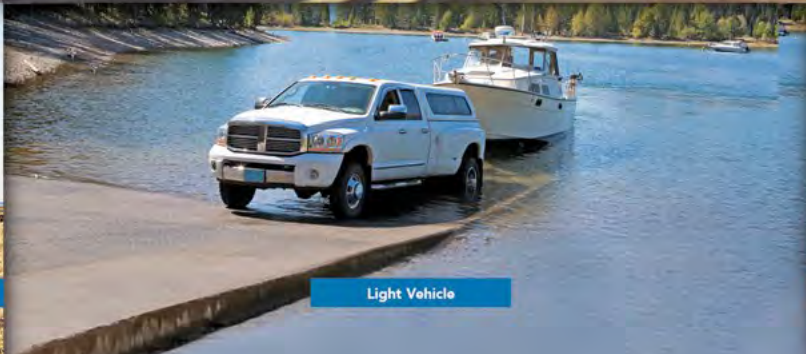

Light Vehicle



Performance

Notes



Off-Road / ATV / UTV



Commercial Vehicle



Industrial



Off-Highway-Ag

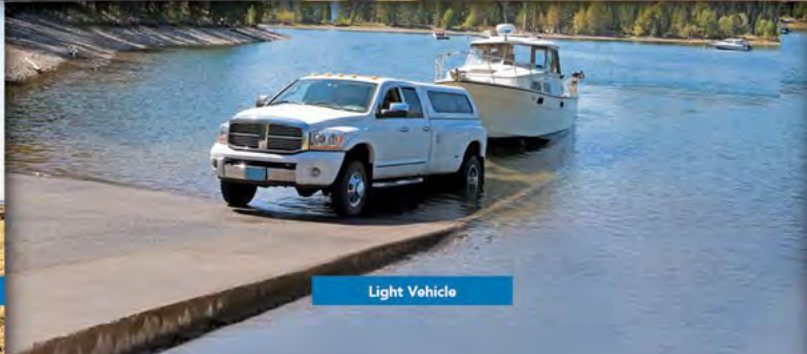

Light Vehicle



Performance

Notes



THE DRIVELINE EXPERTS



Proven Quality Drivelines

Neapco has been manufacturing driveline products for more than 100 years. Founded in 1921 as New England Auto Products Corporation, Neapco has grown to be the largest Tier One driveline supplier in North America. To meet the needs of a growing global marketplace, Neapco has expanded its footprint globally.

Our testing, validation, engineering and design teams have hundreds of years of cumulative driveline expertise. Neapco products range from driveshafts to prop shafts to u-joints and are trusted by the top OEMs for quality, performance, and endurance. Our aftermarket products perform like original equipment products because in many cases they are the original equipment products.

**Manufacturing Driveline Solutions®
in the USA Since 1921.**

NeapcoAftermarket.com

©Neapco LLC 2023



OEMs Trust Neapco for the First Installation.

OEMs around the world trust Neapco's quality, durability and performance for their vehicles as the original equipment installed at the factories.



You can trust us for the next installation.

You can trust Neapco's quality, durability and performance for all your aftermarket installations too.

NeapcoAftermarket.com



Over 80 years of driveline products . . . At the click of a mouse.

You have grown to trust Neapco quality and we have made it easier for you to find the products you need for your next job. Whether you are a vehicle owner or one of our distributors, NeapcoParts.com is your one stop shop.

Vehicle Owners can:

- Search products by: Type, Dimensions, Keywords, Year, Make and Model
- Find the Distributor closest to them

Distributors can:

- Search products by: Type, Dimensions, Keywords, Year, Make and Model
- Order product
- Manage their account
- And much more!

Find what your looking for at NeapcoParts.com!

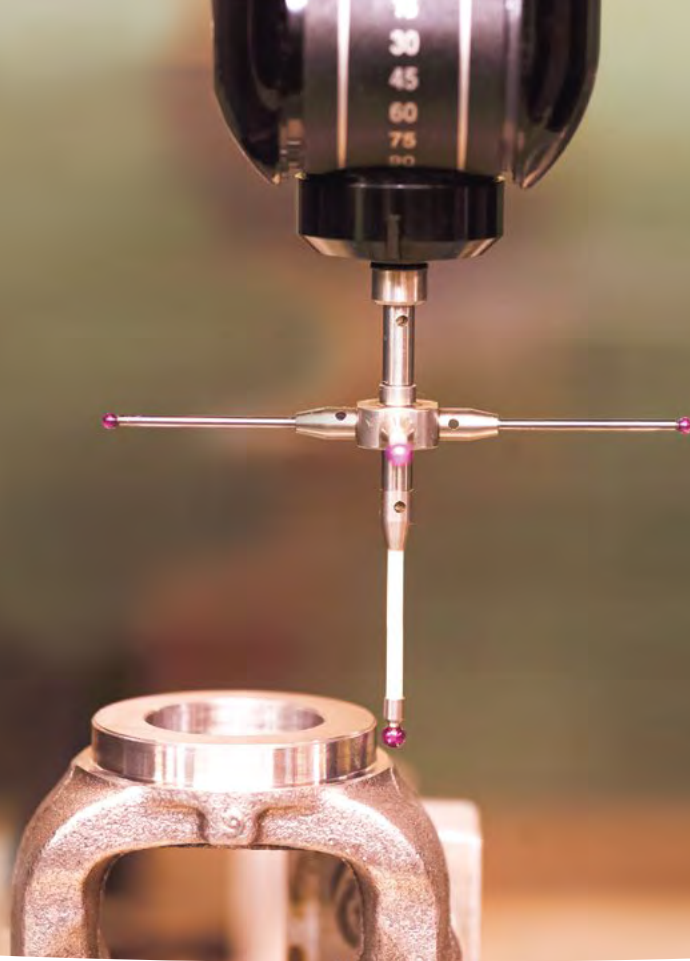

Proven quality drivelines

U.S.A. Based Manufacturer Since 1921

Since being founded in 1921, as New England Auto Products Corporation, Neapco has been designing, manufacturing and distributing OEM and related aftermarket drivelines and components. For nearly 100 years, Neapco has been a trusted name in the global automotive market including:

- Automotive light vehicle
- Commercial vehicle
- Off-highway
- Performance/Enthusiasts
- Other speciality applications

Neapco Products are OE Products

From our engineering and design teams to our testing, validation, sales and marketing teams, Neapco products are backed by hundreds of years of cumulative driveline expertise. Our products perform like original equipment, because they are original equipment on many leading platforms.

Neapco prides itself on providing built in service solutions such as:

- **PlateLock™** universal joints featuring the exclusive slip fit dual-plane retainer system, making it easier to service in the field
- **CheckValve™** which helps insure grease remains in the bearing cups when the u-joint is serviced
- **Fully Balanced** – unlike other manufacturers, Neapco components are fully balanced to make assembly and final balancing easier and more efficient



Proven Quality Drivelines

U.S.A. Based Manufacturing Since 1921

Since being founded in 1921, as New England Auto Products Corporation, Neapco has been designing, manufacturing and distributing OEM and related aftermarket drivelines and components. For nearly 100 years, Neapco has been a trusted name in the global automotive market including:

- Automotive light vehicle
- Commercial vehicle
- Off-highway
- Performance/Enthusiasts
- Other specialty applications



Neapco Genuine
Zerk (grease) fittings
for ease lubrication.

Neapco OE Series
Lubricated for life to
reduce maintenance
costs and vehicle
downtime.

Neapco Performance Series
Designed for extended-life
performance.

Whether it is the industry leading performance of Neapco Genuine, original equipment specifications and performance of Neapco OE Series, or the extended-life and demanding performance of Neapco Performance Series, our products and people are Driven to Deliver. Count on Neapco Products and People.

- Trusted OEM supplier
- Proven performance
- Aftermarket experts
- World-class testing and engineering
- Data-controlled manufacturing
- Industry-leading product coverage and inventories
- Unmatched service and support



Light Vehicles

We are a Tier One supplier with a long history of providing aftermarket driveline systems that are designed, engineered and manufactured to perform like original equipment, because many of our parts are original equipment.

Whether used in daily transportation, fleet service or professional duty, Neapco light-vehicle driveline products and assemblies are made in data-controlled manufacturing facilities in Beatrice, Nebraska and Belleville, Michigan. Our state-of-the-art research and testing facility in Farmington Hills, Michigan insures Neapco provides optimal quality and performance in every part we produce.

Neapco is a major Tier One supplier to many global, light vehicle OEMs, including Ford, GM, FCA, BMW, VW, Mercedes Benz and others.

Typical light vehicles include:

- Passenger cars/SUVs
- Light duty trucks up to Class 3
- Commercial vans
- Electric, Hybrid and alternative fuel vehicles

Our Light Vehicle product portfolio includes:

- Propshafts/Driveshafts
- Driveline components
- Universal joints
- Double cardan assemblies





Commercial Vehicles

Neapco offers aftermarket driveline parts and assemblies you can trust to maximize uptime, and get you where you are going. We provide a full line of fixed-length assemblies and many styles of yokes to interface with other driveline components.

Neapco commercial vehicle products are designed, engineered, and manufactured to meet the application specific demands of each vehicle.

As a global Tier One supplier, Neapco provides precision manufactured products that deliver OEM quality and performance you can trust for the long haul. With our components manufacturing and distribution center based in the heartland of America in Beatrice, NE, and regional distribution centers in Greer, SC and Las Vegas, NV, we have your service parts needs covered from coast to coast.

Typical commercial applications include medium-duty and heavy-duty commercial vehicles, such as:

- Class 8 tractor trailers
- RVs and large motor homes
- Buses
- Fire trucks and emergency vehicles

Our Commercial Vehicle product portfolio includes:

- Propshafts/Driveshafts
- Driveline components
- Universal joints
- Center supports
- Power take-off



INTRODUCING

N350

Neapco OE Series

Part# 6-0350

IN-SHOP, OE-STYLE, PRESS-FIT DESIGN

Designed, Engineered and Manufactured to meet or exceed OE Performance Specifications.

- **HOT FORGED CROSS** heat treated to proprietary levels to provide optimal strength and endurance for the intended, specific application.
- **PRECISION GROUND JOURNALS** provide exceptional strength, durability and load distribution to extend life.
- **PREMIUM SEALING SYSTEM** with needle bearing retainer to keep lube in and environmental contaminants out, while holding needle bearings in optimal position for peak performance and extended life of the joint.
- **PRECISION ENGINEERED, EXTENDED LENGTH NEEDLE BEARINGS** that enhance load distribution and durability for extended life.
- **GLASS IMPREGNATED NYLON THRUST WASHER** eliminates metal to metal contact between the bearings and the cap, to minimize heat and maximize life.
- **PRECISION GROUND BEARING CAP OD** for exact OE press-fit into the yoke.
- **OE-STYLE SNAP RING RETENTION SYSTEM** holds the bearing caps in optimal position for peak performance.

ULTIMATE
STRENGTH

LOW-CYCLE
FATIGUE

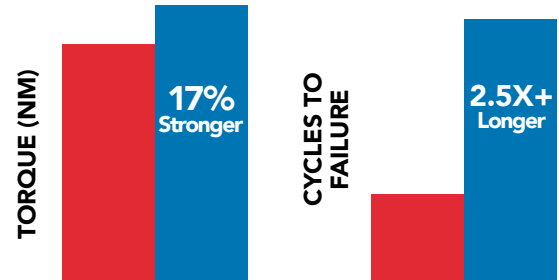

HIGH-CYCLE
FATIGUE

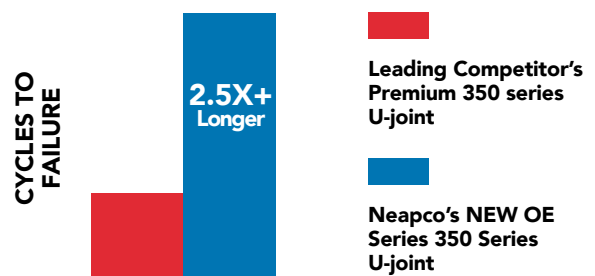

The Best of Both Worlds for SPL[®] Applications Neapco OE Series

Part#s 6-0170 and 6-0250

IN-SHOP, OE-STYLE, PRESS-FIT DESIGN

Designed, Engineered and Manufactured to meet or exceed
OE Performance Specifications.

- **HOT FORGED CROSS** heat treated to proprietary levels to provide ultimate strength that meets demand.
- **PRECISION GROUND JOURNALS** provide optimal strength, durability and load distribution to extend life.
- **PREMIUM SEALING SYSTEM** with needle bearing retainer keeps lube in and environmental contaminants out, while holding needle bearings in optimal position for premium performance and extended life of the joint.
- **PRECISION ENGINEERED, EXTENDED LENGTH NEEDLE BEARINGS** that enhance load distribution and durability for extended life.
- **GLASS IMPREGNATED NYLON THRUST WASHER** eliminates metal to metal contact between the bearings and the cap, to minimize heat and maximize life.
- **PRECISION GROUND BEARING CAP** OD for optimal OE press-fit into the yoke.
- **PRECISION MADE BEARING CAP INSTALLATION DISKS** to ensure proper bearing cap positioning.
- **OE-STYLE RETENTION TABS** hold the bearing caps in precise location to optimize performance.



Genuine Neapco PlateLock® Design

Part#s 6-1170 and 6-1250

IN-FIELD, NO-TOW, HAND-INSTALL DESIGN

Designed, Engineered and Manufactured to meet or exceed OE Performance Specifications, but with a unique design feature for easy, in-field or roadside installation.

- **HOT FORGED CROSS** heat treated to proprietary levels to provide ultimate strength that meets demand.
- **PRECISION GROUND JOURNALS** provide optimal strength, durability and load distribution to extend life.
- **PREMIUM SEALING SYSTEM** with needle bearing retainer keeps lube in and environmental contaminants out, while holding needle bearings in optimal position for premium performance and extended life of the joint.
- **PRECISION ENGINEERED, EXTENDED LENGTH NEEDLE BEARINGS** enhance load distribution and durability for extended life.
- **GLASS IMPREGNATED NYLON THRUST WASHER** eliminates metal to metal contact between the bearings and the cap, to minimize heat and maximize life.
- **PRECISION GROUND BEARING CAP** OD for hand installation into the yoke.
- **UNIQUE PLATELOCK DESIGN BEARING CAP END AND RETENTION TAB** to lock the cap in an optimal position in the yoke ear.





Off-Highway Vehicles

Neapco offers an extensive line of aftermarket products designed, engineered and manufactured to meet the demanding needs of the off-highway industry. Since 1950, we have specialized in producing driveline products for the following applications:

Typical off-highway applications include:

- Agriculture
- Construction
- Forestry
- Material handling
- Mining

We are an OEM supplier to many off-highway equipment manufacturers, including CNH, John Deere, AgCo, and others.



neapco
PERFORMANCE SERIES

BEAST MODE STRENGTH & ENDURANCE

NEAPCO PERFORMANCE SERIES DOMINATES THE COMPETITION



Made in
the U.S.A.

ULTIMATE STRENGTH
(pure brute strength)

LOW-CYCLE FATIGUE
(off-road & racing endurance)

HIGH-CYCLE FATIGUE
(everyday use & towing endurance)



**WE OUTPERFORM OUR COMPETITION,
SO YOU CAN OUTPERFORM YOURS!**



Performance/Enthusiast

Neapco Performance Series™ driveline products are the choice of some of the most recognized names in the racing and off-road industries. Our industry-leading Performance Series products are custom designed, engineered, and manufactured to meet the application demands for the environments where they live. Trust Neapco's application specific designs to provide optimal performance and the confidence you need to get you where you are going.

Typical performance applications include:

- 4x4 Off-road
- Circle track racing
- Drag racing
- ATVs/UTVs
- Street rods



neapco

PERFORMANCE SERIES

Neapco High Performance Grease

Introducing Neapco Performance Series Ultra-Performance Universal Joint Grease and Slip Spline Lubricant. Our products have been specifically developed and validated to be the industry's highest performing grease and lubricant for universal joints and slip splines.

High Cycle Fatigue Comparison

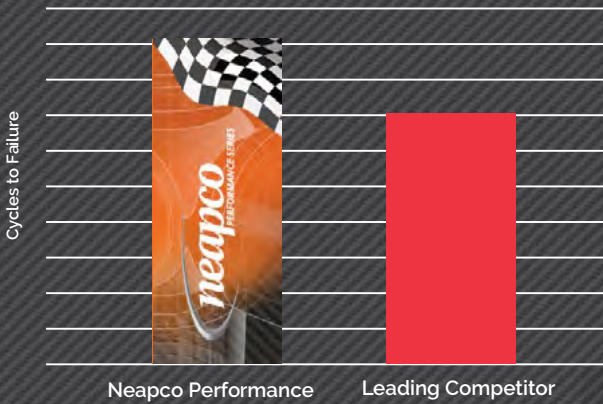

Neapco® Performance Series Universal Joints

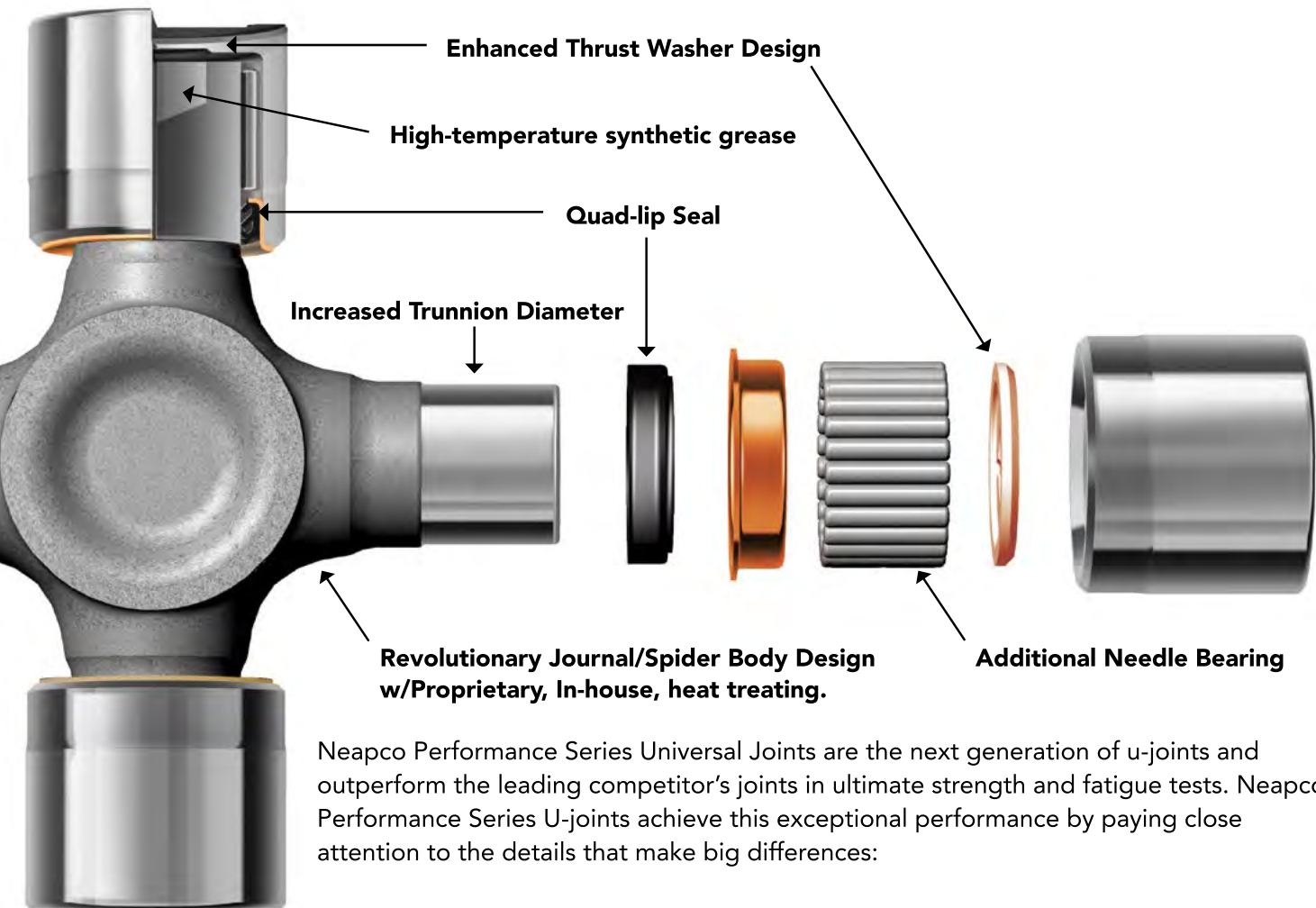

Neapco Performance Series Universal Joints are the next generation of u-joints and outperform the leading competitor's joints in ultimate strength and fatigue tests. Neapco Performance Series U-joints achieve this exceptional performance by paying close attention to the details that make big differences:

- **Enhanced design thrust washer** with a low-friction additive to the material decreases stick-slip and provides lower heat generation, friction, and wear due to new geometry.
- **Increased trunnion diameter** for optimum strength. The addition of a needle bearing and a reduction in grease reservoir depth increases the overall strength and improves stress distribution along the trunnion.
- **A quad-lip seal** prevents grease purging and outside contaminants from entering the u-joints.
- **Revolutionary Journal /Spider Body Design** is re-engineered to provide smoother transitions, ultimately decreasing stress risers throughout the u-joint while the proprietary, in-house heat treating provides Beast Mode strength and durability in all the right places.
- **Neapco Performance Series Ultra-Performance Synthetic U-Joint Grease** provides superior durability, greater water resistance, and is stable across a wide range of temperatures.

The Difference is Clear!



After rigorous head-to-head testing between a Neapco Performance Series U-joint and a Leading Competitor, Neapco lived to see another day. The leading competitor did NOT.

See for yourself.

Dyno Testing for Bearing Life
(Percentage of Prescribed Test Achieved)

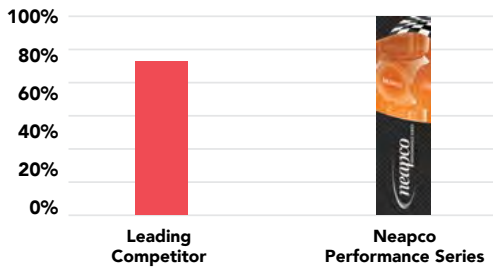

Neapco® Performance Series U-Joint after rigorous head-to-head testing



Leading Competitor U-Joint after rigorous head-to-head testing

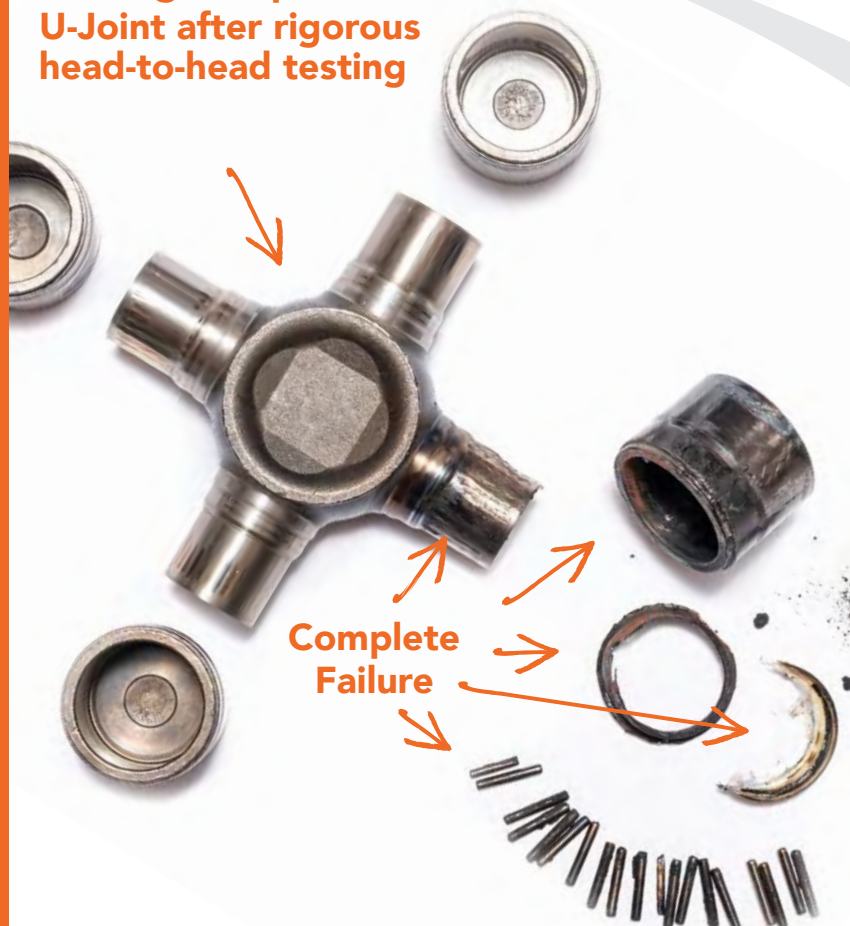

Trust Neapco -

We Outperform the Leading Competitor in Every Series Tested. The Numbers Don't Lie!

- Ultimate Strength (pure brute strength)
- Low-Cycle Fatigue (off-road & racing endurance)
- High-Cycle Fatigue (everyday use and towing endurance)

Test – 1310



Neapco Part# 1-0153P

Ultimate Strength Comparison (B10)

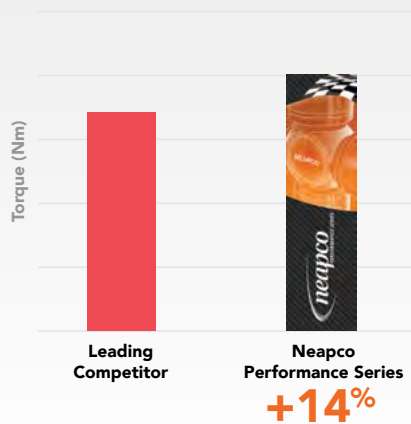

Low-Cycle Fatigue Comparison

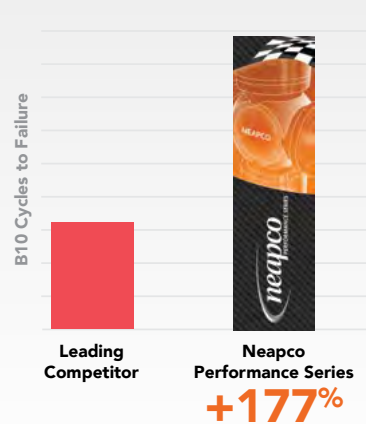

High-Cycle Fatigue Comparison

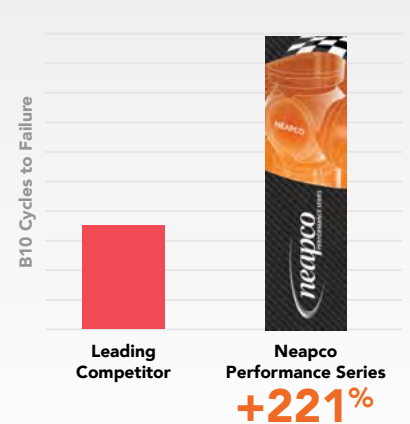

Test – 1330



Neapco Part# 2-4800P

Ultimate Strength Comparison (B10)

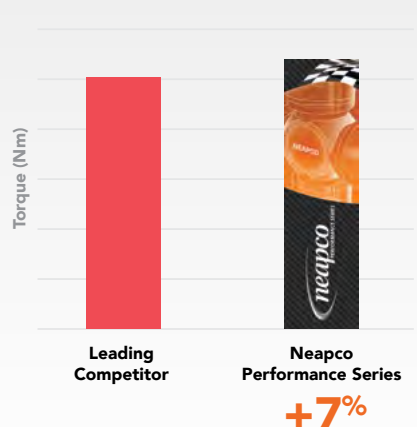

Low-Cycle Fatigue Comparison

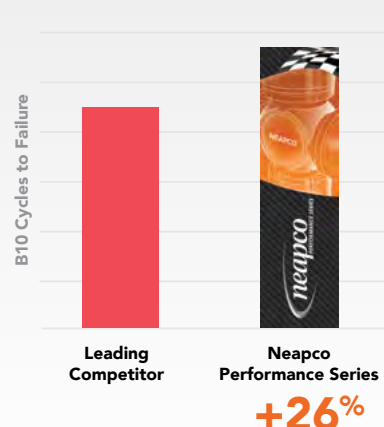

High-Cycle Fatigue Comparison

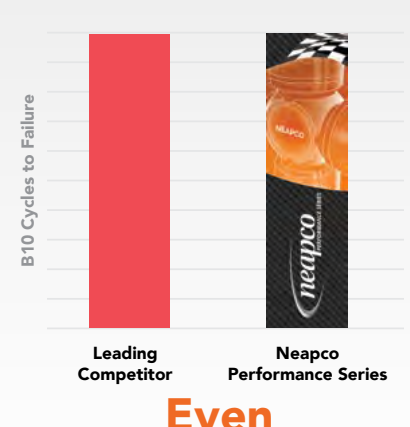

Trust Neapco -

We Outperform the Leading Competitor in Every Series Tested. The Numbers Don't Lie!

- Ultimate Strength (pure brute strength)
- Low-Cycle Fatigue (off-road & racing endurance)
- High-Cycle Fatigue (everyday use and towing endurance)

Test – 1350



Neapco Part# 2-0053P

Ultimate Strength Comparison (B10)

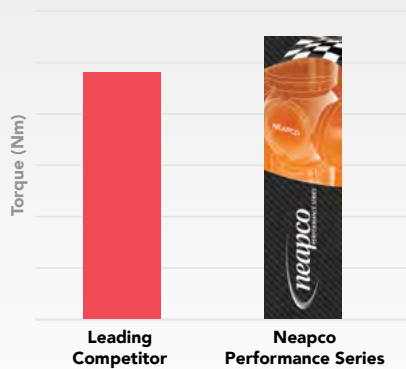

Low-Cycle Fatigue Comparison



High-Cycle Fatigue Comparison

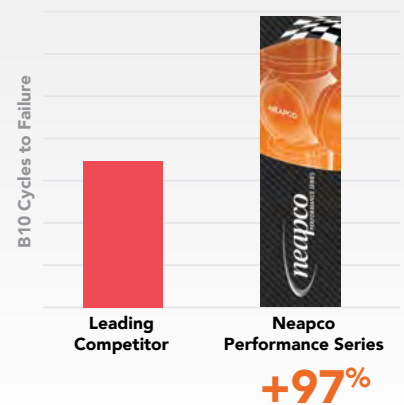

Test – 1410



Neapco Part# 2-0054P

Ultimate Strength Comparison (B10)

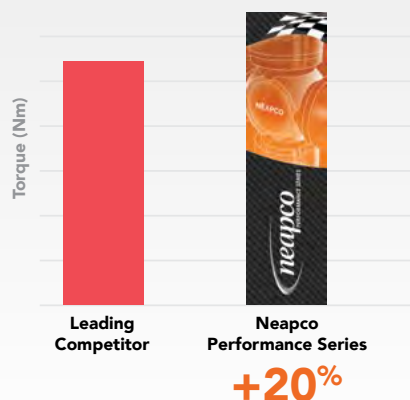

Low-Cycle Fatigue Comparison

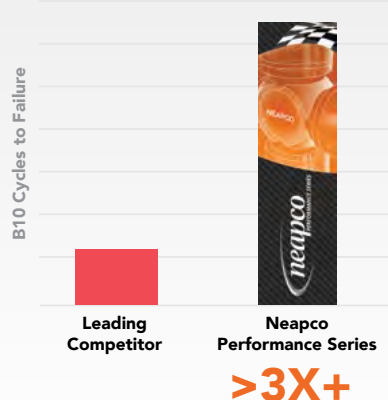

High-Cycle Fatigue Comparison

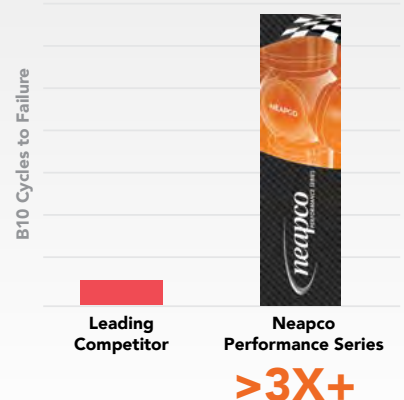



THE DRIVELINE EXPERTS

Companion Flange

Standard Flange

Large Flange

Flange Adapter

SECTION

1



**Manufacturing Driveline Solutions®
in the USA Since 1921.**

NeapcoAftermarket.com

©Neapco LLC 2023

COMPANION FLANGE

STANDARD FLANGE

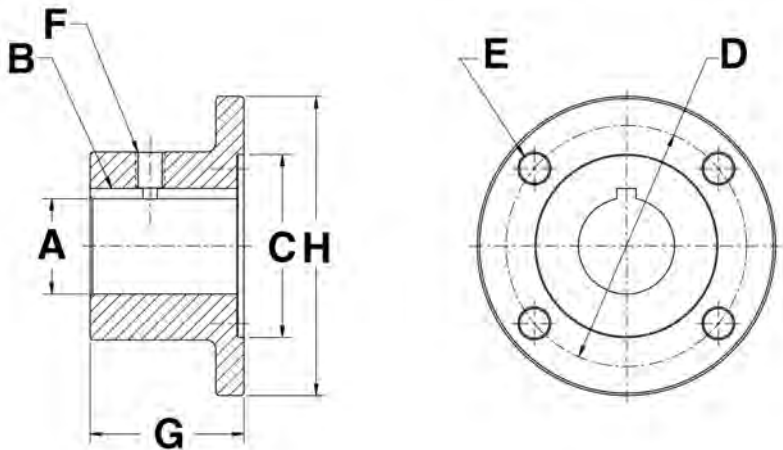

COMPANION FLANGE

DL Series	A Bore Dia.	Bore Dia. (max)	B Keyway	Keyway (max)	C Pilot Dia.	D Bolt Circle	E Hole/Threa Size	Holes/Bolts	F Set Screw Hole Size	G Overall Length	H Outside Dia.	Part Number
1000 Series (Mating Flange Yoke 10-0229)												
1000	1.250	***	0.312	***	2.250	2.750	0.328	4	3/8-16	2.125	3.500	N1-1-273
1000	1.125	***	0.250	***	2.250	2.750	0.328	4	3/8-16	2.125	3.500	N10-1-1022-2
1310 Series (Mating Flange Yoke N2-2-329: use bolt kit N131F)												
1310	0.750	1.688	***	0.375	2.375	3.125	0.391	4	3/8-16	2.000	3.875	N2-1-1313
1310	1.000	***	0.250	0.253	2.375	3.125	0.391	4	3/8-16	2.000	3.875	N2-1-1313-1
1310	1.125	***	0.250	0.253	2.375	3.125	0.391	4	3/8-16	2.000	3.875	N2-1-1313-2
1310	1.250	***	0.250	0.253	2.375	3.125	0.391	4	3/8-16	2.000	3.875	N2-1-1313-3
1310	1.250	***	0.312	0.315	2.375	3.125	0.391	4	3/8-16	2.000	3.875	N2-1-1313-4
1310	1.375	***	0.312	0.315	2.375	3.125	0.391	4	3/8-16	2.000	3.875	N2-1-1313-5
1310	1.375	***	0.375	0.378	2.375	3.125	0.391	4	3/8-16	2.000	3.875	N2-1-1313-6
1310	1.438	***	0.375	0.378	2.375	3.125	0.391	4	3/8-16	2.000	3.875	N2-1-1313-7
1310	1.500	***	0.375	0.378	2.375	3.125	0.391	4	3/8-16	2.000	3.875	N2-1-1313-8
1310	1.625	***	0.375	0.378	2.375	3.125	0.391	4	3/8-16	2.000	3.875	N2-1-1313-9
1350-1410 Series (Mating Flange Yoke 1350: N3-2-119 1410: N3-2-159: use bolt kit N135F)												
1350-1410	1.000	7.875	***	0.500	2.750	3.750	0.454	4	3/8-16	2.000	4.562	N3-1-1013
1350-1410	1.000	***	0.250	0.253	2.750	3.750	0.454	4	3/8-16	2.000	4.562	N3-1-1013-1
1350-1410	1.750	***	0.375	0.378	2.750	3.750	0.454	4	3/8-16	2.000	4.562	N3-1-1013-10
1350-1410	1.875	***	0.375	0.378	2.750	3.750	0.454	4	3/8-16	2.000	4.562	N3-1-1013-11
1350-1410	1.875	***	0.500	0.503	2.750	3.750	0.454	4	3/8-16	2.000	4.562	N3-1-1013-12
1350-1410	1.125	***	0.250	0.253	2.750	3.750	0.454	4	3/8-16	2.000	4.562	N3-1-1013-2
1350-1410	1.250	***	0.250	0.253	2.750	3.750	0.454	4	3/8-16	2.000	4.562	N3-1-1013-3
1350-1410	1.250	***	0.312	0.315	2.750	3.750	0.454	4	3/8-16	2.000	4.562	N3-1-1013-4
1350-1410	1.375	***	0.312	0.315	2.750	3.750	0.454	4	3/8-16	2.000	4.562	N3-1-1013-5
1350-1410	1.375	***	0.375	0.378	2.750	3.750	0.454	4	3/8-16	2.000	4.562	N3-1-1013-6
1350-1410	1.438	***	0.375	0.378	2.750	3.750	0.454	4	3/8-16	2.000	4.562	N3-1-1013-7
1350-1410	1.500	***	0.375	0.378	2.750	3.750	0.454	4	3/8-16	2.000	4.562	N3-1-1013-8
1350-1410	1.625	***	0.375	0.378	2.750	3.750	0.454	4	3/8-16	2.000	4.562	N3-1-1013-9

COMPANION FLANGE

STANDARD FLANGE (Cont'd)

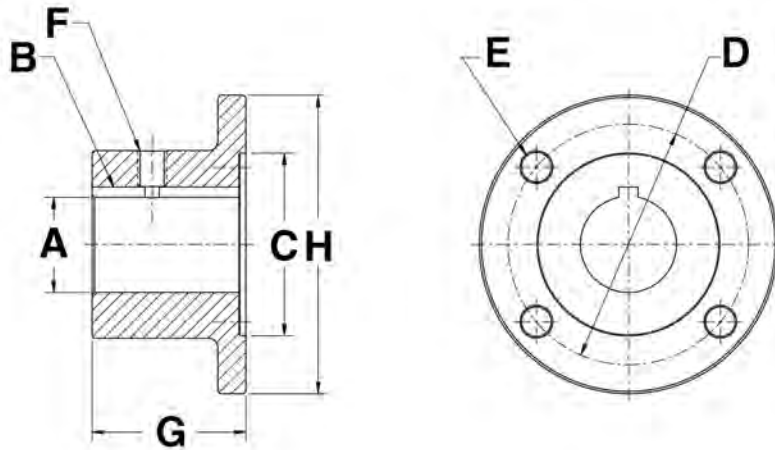

DL Series	A Bore Dia.	Bore Dia. (max)	B Keyway	Keyway (max)	C Pilot Dia.	D Bolt Circle	E Hole/Threa Size	Holes/Bolts	F Set Screw Hole Size	G Overall Length	H Outside Dia.	Part Number
1480-1550 Series (Mating Flange Yoke 1480: N3-2-479 1550 : N4-2-669: use bolt kit N148F)												
1480-1550	1.250	2.438	***	***	3.750	4.750	0.516	4	1/2-13	2.500	5.875	N4-1-1133
1480-1550	1.500	***	0.375	***	3.750	4.750	0.516	4	1/2-13	2.500	5.875	N4-1-1133-1
1480-1550	2.438	***	0.625	0.628	3.750	4.750	0.516	4	1/2-13	2.500	5.875	N4-1-1133-10
1480-1550	2.250	***	0.500	0.503	3.750	4.750	0.516	4	1/2-13	2.500	5.875	N4-1-1133-13
1480-1550	1.625	***	0.375	0.378	3.750	4.750	0.516	4	1/2-13	2.500	5.875	N4-1-1133-2
1480-1550	1.750	***	0.375	0.378	3.750	4.750	0.516	4	1/2-13	2.500	5.875	N4-1-1133-3
1480-1550	1.875	***	0.375	0.378	3.750	4.750	0.516	4	1/2-13	2.500	5.875	N4-1-1133-4
1480-1550	1.875	***	0.500	0.503	3.750	4.750	0.516	4	1/2-13	2.500	5.875	N4-1-1133-5
1480-1550	2.000	***	0.500	0.503	3.750	4.750	0.516	4	1/2-13	2.500	5.875	N4-1-1133-6
1480-1550	2.125	***	0.500	0.503	3.750	4.750	0.516	4	1/2-13	2.500	5.875	N4-1-1133-7
1480-1550	2.250	***	0.625	0.628	3.750	4.750	0.516	4	1/2-13	2.500	5.875	N4-1-1133-8
1480-1550	2.375	***	0.625	0.628	3.750	4.750	0.516	4	1/2-13	2.500	5.875	N4-1-1133-9
1610 Series (Mating Flange Yoke N5-2-279: use bolt kit N161F)												
1610	1.250	3.000	***	0.750	6.625	6.125	0.391	8	1/2-13	3.500	6.875	N5-1-873
1610	2.000	***	0.500	0.503	6.625	6.125	0.391	8	1/2-13	3.500	6.875	N5-1-873-1
1610	2.250	***	0.625	0.628	6.625	6.125	0.391	8	1/2-13	3.500	6.875	N5-1-873-3
1610	2.375	***	0.625	0.628	6.625	6.125	0.391	8	1/2-13	3.500	6.875	N5-1-873-4
1610	2.438	***	0.625	0.628	6.625	6.125	0.391	8	1/2-13	3.500	6.875	N5-1-873-5
1610	2.500	***	0.625	0.628	6.625	6.125	0.391	8	1/2-13	3.500	6.875	N5-1-873-6
1610	2.750	***	0.625	0.628	6.625	6.125	0.391	8	1/2-13	3.500	6.875	N5-1-873-7
1610	2.938	***	0.750	0.753	6.625	6.125	0.391	8	1/2-13	3.500	6.875	N5-1-873-8
1610	3.000	***	0.750	0.753	6.625	6.125	0.391	8	1/2-13	3.500	6.875	N5-1-873-9

COMPANION FLANGE

COMPANION FLANGE

STANDARD FLANGE (Cont'd)

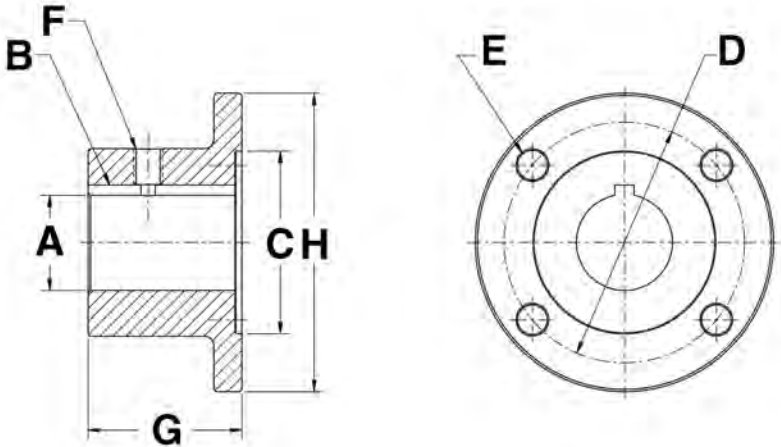

DL Series	A Bore Dia.	Bore Dia. (max)	B Keyway	Keyway (max)	C Pilot Dia.	D Bolt Circle	E Hole/Threa Size	Holes/Bolts	F Set Screw Hole Size	G Overall Length	H Outside Dia.	Part Number
1710 Series (Mating Flange Yoke N6-2-749)												
1710	1.250	4.000	***	1.000	7.750	7.250	0.391	8	***	4.000	8.000	N6-1-1253
1710	2.438	***	0.625	0.628	7.750	7.250	0.391	8	1/2-13	4.000	8.000	N6-1-1253-1
1710	2.125	***	0.500	0.503	7.750	7.250	0.391	8	1/2-13	4.000	8.000	N6-1-1253-10
1710	2.250	***	0.625	0.628	7.750	7.250	0.391	8	1/2-13	4.000	8.000	N6-1-1253-11
1710	2.375	***	0.625	0.628	7.750	7.250	0.391	8	1/2-13	4.000	8.000	N6-1-1253-12
1710 Series (Mating Flange Yoke N6-2-749)												
1710	2.500	***	0.625	0.628	7.750	7.250	0.391	8	1/2-13	4.000	8.000	N6-1-1253-2
1710	2.750	***	0.625	0.628	7.750	7.250	0.391	8	1/2-13	4.000	8.000	N6-1-1253-3
1710	2.938	***	0.750	0.753	7.750	7.250	0.391	8	1/2-13	4.000	8.000	N6-1-1253-4
1710	3.000	***	0.750	0.753	7.750	7.250	0.391	8	1/2-13	4.000	8.000	N6-1-1253-5
1710	3.500	***	0.875	0.878	7.750	7.250	0.391	8	1/2-13	4.000	8.000	N6-1-1253-6
1710	3.938	***	1.000	1.003	7.750	7.250	0.391	8	1/2-13	4.000	8.000	N6-1-1253-7
1710	4.000	***	1.000	1.003	7.750	7.250	0.391	8	1/2-13	4.000	8.000	N6-1-1253-8
1710	2.000	***	0.500	0.503	7.750	7.250	0.391	8	1/2-13	4.000	8.000	N6-1-1253-9
1810 Series (Mating Flange Yoke N6.5-2-329)												
1810	1.250	4.000	***	1.000	7.750	7.250	0.545	12	1/2-13	4.000	8.000	N6.5-1-533
1810	2.438	***	0.625	0.628	7.750	7.250	0.454	12	1/2-13	4.000	8.000	N6.5-1-533-1
1810	2.500	***	0.625	0.628	7.750	7.250	0.454	12	1/2-13	4.000	8.000	N6.5-1-533-2
1810	2.750	***	0.625	0.628	7.750	7.250	0.454	12	1/2-13	4.000	8.000	N6.5-1-533-3
1810	2.938	***	0.750	0.753	7.750	7.250	0.454	12	1/2-13	4.000	8.000	N6.5-1-533-4
1810	3.000	***	0.750	0.753	7.750	7.250	0.454	12	1/2-13	4.000	8.000	N6.5-1-533-5
1810	3.500	***	0.875	0.878	7.750	7.250	0.454	12	1/2-13	4.000	8.000	N6.5-1-533-6
1810	3.938	***	1.000	1.003	7.750	7.250	0.454	12	1/2-13	4.000	8.000	N6.5-1-533-7
1810	4.000	***	1.000	1.003	7.750	7.250	0.454	12	1/2-13	4.000	8.000	N6.5-1-533-8

COMPANION FLANGE

LARGE FLANGE

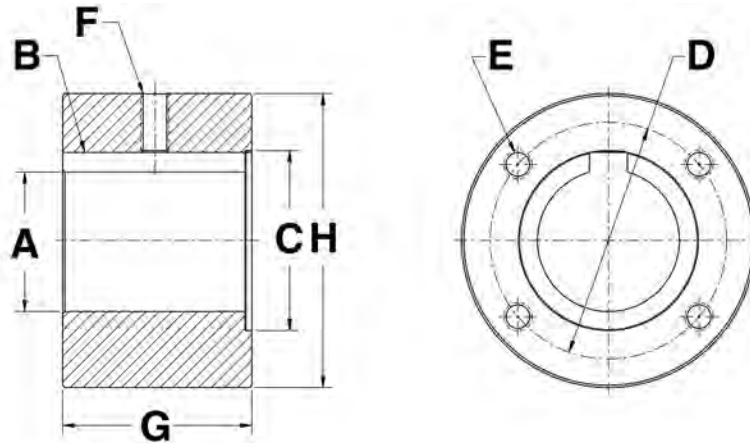

DL Series	A Bore Dia.	Bore Dia. (max)	B Keyway	Keyway (max)	C Pilot Dia.	D Bolt Circle	E Hole/Threa Size	Holes/Bolts	F Set Screw Hole Size	G Overall Length	H Outside Dia.	Part Number
1310 Series (Mating Flange Yoke N2-2-329)												
1310	1.375	2.375	***	0.625	2.375	3.125	3/8-24	4	3/8-16	2.500	3.875	N2-1-1323
1310	1.750	***	0.375	0.378	2.375	3.125	3/8-24	4	3/8-16	2.500	3.875	N2-1-1323-1
1310	1.875	***	0.375	0.378	2.375	3.125	3/8-24	4	3/8-16	2.500	3.875	N2-1-1323-2
1310	1.875	***	0.500	0.503	2.375	3.125	3/8-24	4	3/8-16	2.500	3.875	N2-1-1323-3
1310	2.000	***	0.500	0.503	2.375	3.125	3/8-24	4	3/8-16	2.500	3.875	N2-1-1323-4
1310	2.125	***	0.500	0.503	2.375	3.125	3/8-24	4	3/8-16	2.500	3.875	N2-1-1323-5
1310	2.250	***	0.625	0.628	2.375	3.125	3/8-24	4	3/8-16	2.500	3.875	N2-1-1323-6
1310	2.375	***	0.625	0.628	2.375	3.125	3/8-24	4	3/8-16	2.500	3.875	N2-1-1323-7
1310	2.250	***	0.500	0.503	2.375	3.125	3/8-24	4	3/8-16	2.500	3.875	N2-1-1323-8
1350-1410 Series (Mating Flange Yoke 1350: N3-2-119 1410: N3-2-159)												
1350-1410	1.750	3.000	***	0.750	2.750	3.750	7/16-20	4	3/8-16	3.000	4.562	N3-1-1023
1350-1410	2.000	***	0.500	0.503	2.750	3.750	7/16-20	4	3/8-16	3.000	4.562	N3-1-1023-1
1350-1410	2.250	***	0.500	0.503	2.750	3.750	7/16-20	4	3/8-16	3.000	4.562	N3-1-1023-10
1350-1410	2.125	***	0.500	0.503	2.750	3.750	7/16-20	4	3/8-16	3.000	4.562	N3-1-1023-2
1350-1410	2.250	***	0.625	0.628	2.750	3.750	7/16-20	4	3/8-16	3.000	4.562	N3-1-1023-3
1350-1410	2.375	***	0.625	0.628	2.750	3.750	7/16-20	4	3/8-16	3.000	4.562	N3-1-1023-4
1350-1410	2.438	***	0.625	0.628	2.750	3.750	7/16-20	4	3/8-16	3.000	4.562	N3-1-1023-5
1350-1410	2.500	***	0.625	0.628	2.750	3.750	7/16-20	4	3/8-16	3.000	4.562	N3-1-1023-6
1480-1550 Series (Mating Flange Yoke 1480: N3-2-479 1550 : N4-2-669)												
1480-1550	2.375	3.750	***	1.000	3.750	4.750	1/2-20	4	1/2-13	3.000	5.875	N4-1-1143
1480-1550	2.500	***	0.625	0.628	3.750	4.750	1/2-20	4	1/2-13	3.000	5.875	N4-1-1143-1
1480-1550	2.750	***	0.625	0.628	3.750	4.750	1/2-20	4	1/2-13	3.000	5.875	N4-1-1143-2
1480-1550	2.938	***	0.750	0.753	3.750	4.750	1/2-20	4	1/2-13	3.000	5.875	N4-1-1143-3
1480-1550	3.000	***	0.750	0.753	3.750	4.750	1/2-20	4	1/2-13	3.000	5.875	N4-1-1143-4
1480-1550	3.500	***	0.875	0.878	3.750	4.750	1/2-20	4	1/2-13	3.000	5.875	N4-1-1143-5

COMPANION FLANGE

LARGE FLANGE (Cont'd)

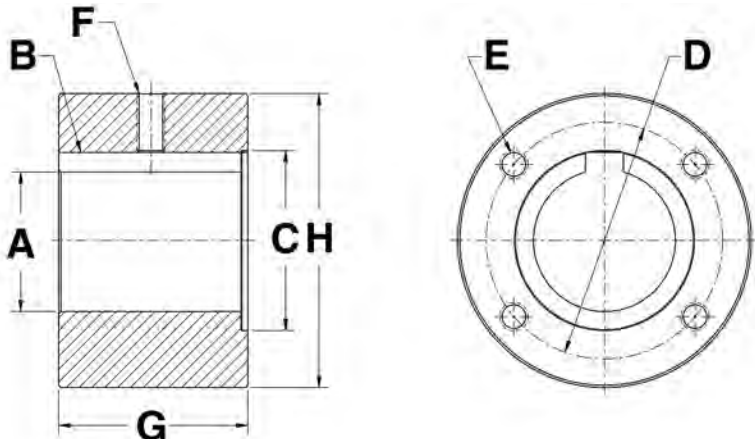

DL Series	A Bore Dia.	Bore Dia. (max)	B Keyway	Keyway (max)	C Pilot Dia.	D Bolt Circle	E Hole/Threa Size	Holes/Bolts	F Set Screw Hole Size	G Overall Length	H Outside Dia.	Part Number
1610 Series (Mating Flange Yoke N5-2-279: use bolt kit N161F)												
1610	3.125	4.500	***	1.000	6.625	6.125	3/8-24	8	1/2-13	5.000	6.875	N5-1-883
1610	3.500	***	0.875	0.878	6.625	6.125	3/8-24	8	1/2-13	5.000	6.875	N5-1-883-1
1610	4.000	***	1.000	1.003	6.625	6.125	3/8-24	8	1/2-13	5.000	6.875	N5-1-883-3
1710 Series (Mating Flange Yoke N6-2-749)												
1710	3.500	5.500	***	1.250	7.750	7.250	3/8-24	8	1/2-13	6.000	8.000	N6-1-1263
1810 Series (Mating Flange Yoke N6.5-2-329)												
1810	3.500	5.500	***	1.250	7.750	7.250	7/16-20	12	1/2-13	6.000	8.000	N6.5-1-543

COMPANION FLANGE

COMPANION FLANGE

FLANGE ADAPTER

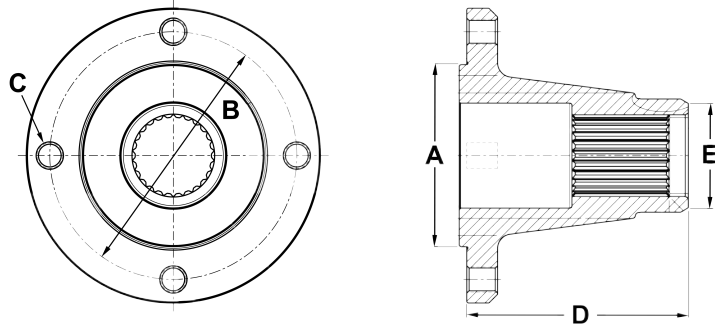

DL Series	A Pilot Dia.	B Bolt Circle	C Hole/Thread Size	Holes/Bolts	D Flange Face To End	E Hub Dia.	Spline/ Number Teeth	Part Number
1350 Series (Mating Flange Yoke N3-2-119)								
1350	3.125-M	4.250	7/16-20	4	2.53	1.938	1.401-32	N3-1-JK05
1350	3.125-M	4.250	7/16-20	4	3.81	1.938	1.401-32	N3-1-JK07

COMPANION FLANGE

COMPANION FLANGE

Notes



THE DRIVELINE EXPERTS

Flange Yoke

Inside Lock-Up

Outside Lock-Up

Bearing Plate Construction

C.V. Flange Adapter

C.V. Outside Lock-Up

C.V. Inside Lock-Up

Torque Limiter

SECTION

2



**Manufacturing Driveline Solutions®
in the USA Since 1921.**

NeapcoAftermarket.com

©Neapco LLC 2023

FLANGE YOKE

INSIDE LOCK-UP

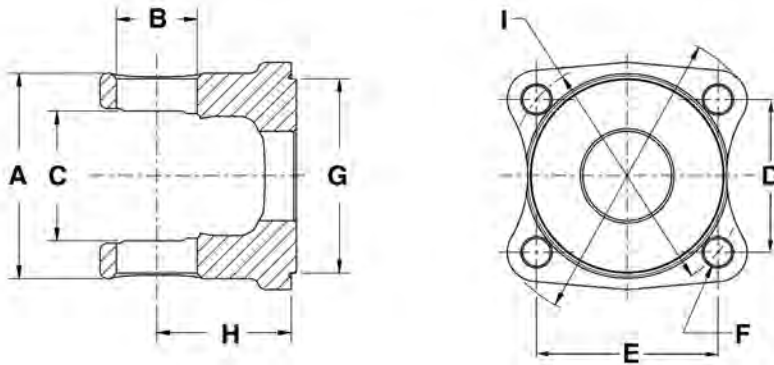

DL Series	D Length Between Holes	E Length Between Holes	F Hole/ Thread Size	G Pilot Dia.	H Flange Face To CL	I Bolt Circle Hub Dia.	Number Of Bolt Holes	CL To End Of Hub	Spline/ Number Teeth	Bolt Hole Pattern	Part Number	
1000 Series A-2.312 B-0.938 C-1.500												
1000	1.768	2.107	0.328	2.250-M	1.562	2.750	***	4	***	***	Rectangle	10-0229
1000	1.768	2.107	0.320	2.000-M	1.249	2.750	***	4	***	***	Rectangle	NOE-02-2653-A
1000	1.768	2.107	0.320	2.000-M	1.249	2.750	***	4	***	***	Rectangle	NOE-02-2655-A
1000	***	***	0.328	2.756	2.562	3.250	***	4	***	***	Round	NOE-02-2126-A
1000	***	***	5/16-18 UNC Thru	3.000	1.000	3.375	1.600	4	2.500	.984-22	Round	NOE-02-2171-A
1200 Series A-2.562 B-1.063 C-1.812												
1200	2.767	2.767	0.465	***	2.150	3.913	***	4	***	***	Square	12-1535

FLANGE YOKE

OUTSIDE LOCKUP

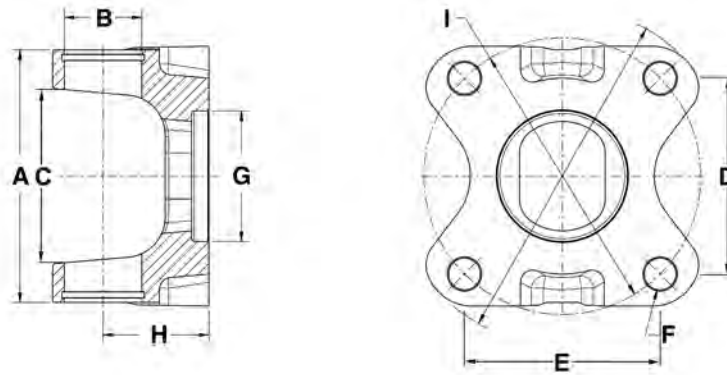

FLANGE YOKE

DL Series	C Length Between Holes	D Length Between Holes	E Bolt Circle	F Hole/Thread Size	G Pilot Dia.	H Flange Face To CL	I Hub Dia.	Number Of Bolt Holes	Joint Angle	CL To End Of Hub	Bolt Hole Pattern	Part Number
1210 Series A-2.56 B-1.063												
1210	2.475	2.475	3.500	0.500	2.000-F	1.625	***	4	20	***	Square	N2-2-1049
1210	2.165	2.165	3.062	0.328	1.812-M	1.500	***	4	20	***	Square	N2-2-2323
1210	1.768	2.107	2.750	0.328	2.250-M	1.484	***	4	20	***	Rectangle	N2-2-899
1310 Series A-3.469 B-1.063												
1310	3.005	3.005	4.250	0.500	2.000-F	1.625	***	4	19	***	Square	N2-2-1379
1310	2.652	2.652	3.750	0.484	2.562-M	1.562	***	4	22	***	Square	N2-2-1949-1
1310	***	***	3.391	0.328	3.938-M	2.188	***	6	20	***	Round	N2-2-206
1310	2.009	2.394	3.125	0.391	2.375-M	1.375	***	4	20	***	Rectangle	N2-2-329
1310	1.848	2.202	2.875	0.391	3.625-M	1.375	***	4	20	***	Rectangle	N2-2-349
1310	***	***	3.391	0.328	3.922-M	2.312	***	8	20	***	Round	N2-2-392
1310	2.009	2.394	3.125	0.391	2.375-M	1.625	***	4	30	***	Rectangle	N2-2-459
1310	2.410	2.873	3.750	0.454	2.750-M	1.375	***	4	20	***	Rectangle	N2-2-479
1310	3.053	3.639	4.750	0.516	3.750-M	1.375	***	4	20	***	Rectangle	N2-2-579
1310	2.596	2.596	3.672	0.454	1.812-M	1.562	***	4	20	***	Square	N2-2-780
1310	2.205	2.520	3.344	0.328	1.812-M	1.625	***	4	15	***	Rectangle	N2-2-799
1310	2.365	2.365	3.344	0.406	1.812-M	1.625	***	4	15	***	Square	N2-2-799-1
1310	1.768	2.107	2.750	0.328	2.250-M	1.625	***	4	15	***	Rectangle	N2-2-899-1
1310	2.475	2.475	3.500	0.500	2.000-F	1.625	***	4	20	***	Square	N2-2-939
1310	***	***	3.543	0.325	2.800-M	2.280	4.09	8	***	***	Round	N2-2-JL01
1330 Series A-3.875 B-1.063												
1330	3.005	3.005	4.250	0.500	2.000-F	1.625	***	4	19	***	Square	N2-2-1369
1330	2.785	2.785	3.938	0.500	2.156-F	1.625	***	4	20	***	Square	N2-2-1879-1
1330	2.596	2.596	3.672	0.454	1.812-M	1.562	***	4	20	***	Square	N2-2-1904
1330	2.596	2.596	3.672	0.500	1.812-M	1.562	***	4	20	***	Square	N2-2-2768
1330	2.410	2.873	3.750	0.454	2.750-M	1.562	***	4	20	***	Rectangle	N2-2-489
1330	2.475	2.475	3.500	0.500	2.000-F	1.656	***	4	20	***	Square	N2-2-949

FLANGE YOKE

OUTSIDE LOCKUP (Cont'd)

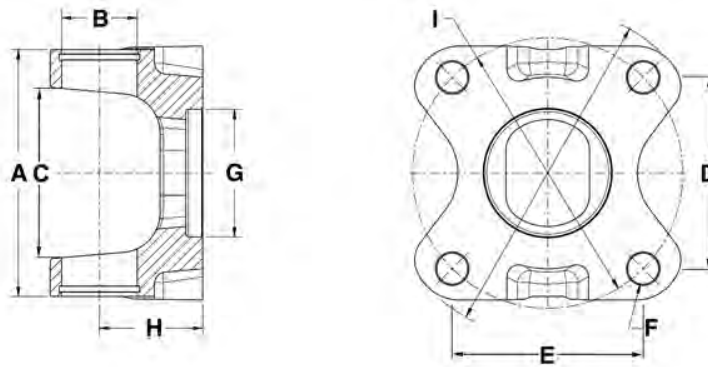

DL Series	C Length Between Holes	D Length Between Holes	E Bolt Circle	F Hole/ Thread Size	G Pilot Dia.	H Flange Face To CL	I Hub Dia.	Number Of Bolt Holes	Joint Angle	CL To End Of Hub	Bolt Hole Pattern	Part Number
1350 Series A-3.875 B-1.188												
1350	2.410	2.873	3.750	0.454	2.750-M	1.562	***	4	20	***	Rectangle	N3-2-119
1350	2.826	2.826	3.996	0.406	2.950-F	1.693	***	4	***	1.693	Square	N3-2-1351
1350	3.005	3.005	4.250	0.500	2.000-F	1.650	***	4	20	1.650	Square	N3-2-1579F
1350	3.005	3.005	4.250	M12x1.75	2.000-F	1.625	***	4	20	***	Square	N3-2-1619
1350	3.005	3.005	4.250	M12x1.75	2.688-F	1.625	***	4	20	***	Square	N3-2-1699
1350	3.359	3.359	4.750	0.490	2.950-F	1.650	***	4	***	***	Square	N3-2-1859
1350	2.645	2.645	3.750	0.500	2.562-M	1.562	***	4	20	***	Square	N3-2-1949
1350	***	***	3.740	0.410	2.800-M	2.480	4.46	6	***	***	Round	N3-2-2701-1X
1350	2.828	2.828	4.000	0.406	2.250-F	1.625	***	4	20	***	Square	N3-2-5104
1350	2.834	3.377	4.409	0.406	2.641-F	1.625	***	4	20	***	Rectangle	N3-2-5107
1350	***	***	3.543	0.325	2.800-F	2.480	4.09	8	***	***	Round	N3-2-JL01
1410 Series A-4.438 B-1.188												
1410	2.410	2.873	3.750	0.454	2.750-M	1.688	***	4	22	***	Rectangle	N3-2-159
1410	3.005	3.005	4.250	M12x1.75	2.688-F	1.656	***	4	20	***	Square	N3-2-1709
1410	3.005	3.005	4.250	0.500	2.688-F	1.656	***	4	20	***	Square	N3-2-1759
1410	3.005	3.005	4.250	0.500	2.000-F	1.656	***	4	20	***	Square	N3-2-1819
1410	3.359	3.359	4.750	0.500	2.953-F	2.000	***	4	25	***	Square	N3-2-1839
1410	3.053	3.639	4.750	0.500	3.750-M	2.000	***	4	30	***	Rectangle	N3-2-429
1480 Series A-4.438 B-1.375												
1480	3.053	3.639	4.750	0.500	3.750-M	2.000	***	4	20	***	Rectangle	N3-2-479
1480	***	***	6.125	0.375	6.625-M	2.000	***	8	20	***	Round	N3-2-499
1550 Series A-5.250 B-1.375												
1550	3.053	3.639	4.750	0.500	3.750-M	2.000	***	4	22	***	Rectangle	N4-2-669

FLANGE YOKE

BEARING PLATE CONSTRUCTION

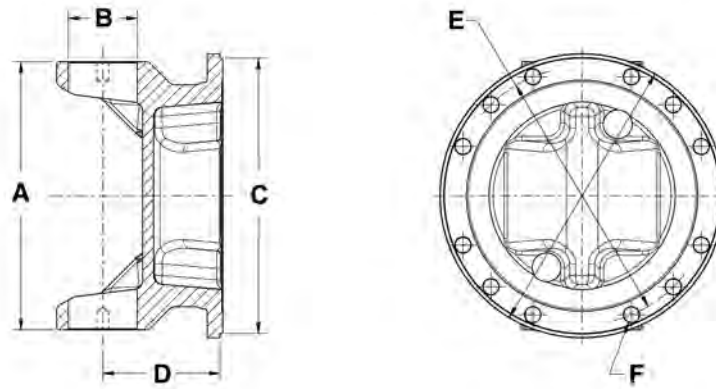

FLANGE YOKE

DL Series	C Pilot Dia.	D Flange Face To CL	E Bolt Circle	F Hole/ Thread Size	Number Of Bolt Holes	Joint Angle	Bolt Hole Pattern	Part Number
1610 Series				A-5.321	B-1.875			
1610	6.625-M	2.750	6.125	0.375	8	22	Round	N5-2-279
1710 Series				A-6.094	B-1.938			
1710	7.750-M	3.000	7.250	0.438	8	22/29	Round	N6-2-739
1710	7.750-M	3.000	7.250	0.375	8	22/29	Round	N6-2-749
1760 Series				A-7.000	B-1.938			
1760	7.750-M	3.375	7.250	0.438	12	30	Round	N6.3-2-19
1810 Series				A-7.547	B-1.938			
1810	7.750-M	3.375	7.250	0.438	12	30	Round	N6.5-2-329

FLANGE YOKE

C.V. FLANGE ADAPTER

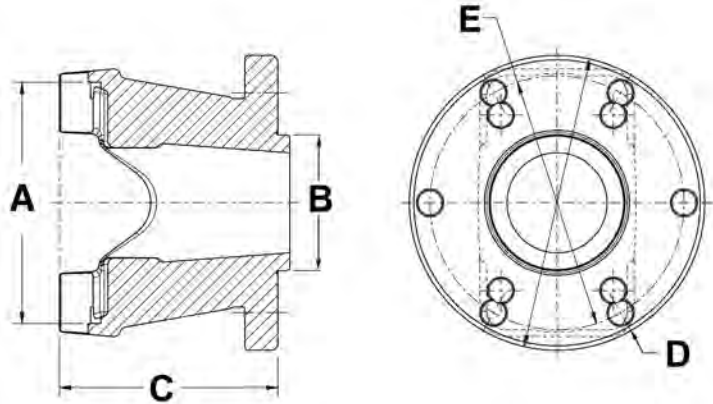

DL Series	B Pilot Dia.	C Flange Face To CL	D Hole/ Thread Size	E Bolt Circle	Number Of Bolt Holes	Bolt Hole Pattern	Part Number
1310HR Series A-3.219 B-1.063							
1310HR	3.938-M	2.906	0.328	3.391	6	Round	N2-83-206
1310HR	4.094-M	2.906	0.328	3.578	6	Round	N2-83-288X

FLANGE YOKE

C.V. OUTSIDE LOCK-UP

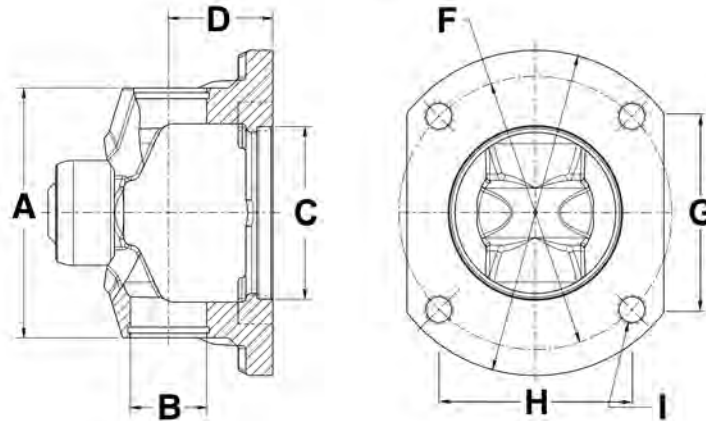

FLANGE YOKE

DL Series	C Pilot Dia.	D Flange Face To CL	Number Of Bolt Holes	E Stud Socket Dim.	F Bolt Circle	G Length Between Holes	H Length Between Holes	I Hole/ Thread Size	Lubrication Type	Bolt Hole Pattern	Part Number
1310 Series		A-3.469		B-1.063							
1310	1.812-M	1.625	4	0.500	3.578	2.362	2.697	0.328	***	Rectangle	N2-83-288-1X
1310	1.812-M	1.625	4	0.500	3.344	2.205	2.52	0.406	***	Rectangle	N2-83-288-2X
1310	1.812-M	1.625	4	0.500	3.344	2.365	2.365	0.406	***	Square	N2-83-288-3X
1310	1.812-M	1.625	4	0.500	3.672	2.596	2.596	0.454	***	Square	N2-83-288-4X
1310	2.000-F	1.625	4	0.500	3.500	2.475	2.475	0.500	GREASABLE	Square	N2-83-388X
1310	2.000-F	1.625	4	0.500	3.500	2.475	2.475	0.500	NON-GREASABLE	Square	N2-83-543X
1310	2.000-F	1.625	4	0.500	3.000	2.121	2.121	0.375-24	***	Square	N2-83-599X
1330 Series		A-3.875		B-1.063							
1330	2.000-F	1.625	4	0.500	4.250	3.005	3.005	M12x1.75	***	Square	N2-83-631X
1330	3.125-F	1.625	4	0.500	4.250	3.005	3.005	0.469	***	Square	N2-83-913X
1350 Series		A-3.875		B-1.188							
1350	3.125-F	1.625	4	0.500	3.938	2.635	2.927	0.469	***	Rectangle	N3-83-1606X
1350	3.125-F	1.625	4	0.500	4.250	3.005	3.005	0.469	***	Square	N3-83-3281X
1350	2.000-F	1.625	4	0.500	4.250	3.005	3.005	M12x1.75	***	Square	N3-83-024X
1350	2.688-F	1.625	4	0.500	4.250	3.005	3.005	M12x1.75	***	Square	N3-83-025X
1350	2.156-F	1.625	4	0.500	3.938	2.785	2.785	0.500	***	Square	N3-83-072X
1410 Series		A-4.438		B-1.188							
1410	3.128	***	4	***	4.250	3.005	3.005	0.463	***	Square	N3-83-1410X
1410	2.680	***	4	***	4.250	3.005	3.005	0.463	***	Square	N3-83-1411X
3R Series		A-3.563		B-1.125		C-2.563					
3R	3.125-F	1.688	4	0.906	4.250	***	***	0.454	***	Round	N3R-83-482
3R	3.125-F	1.688	4	0.906	4.250	***	***	0.406	***	Round	N3R-83-627

FLANGE YOKE

C.V. INSIDE LOCK-UP

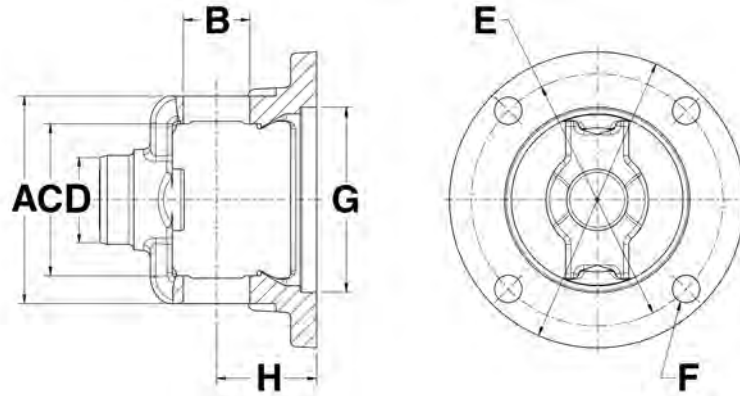

DL Series	D Stud Socket Dim.	E Bolt Circle	F Hole/Thread Size	G Pilot Dia.	H Flange Face To CL	Number Of Bolt Holes	Bolt Hole Pattern	Part Number
3R Series				A-3.563	B-1.125	C-2.563		
3R	0.906	4.250	0.454	3.125-F	1.688	4	Round	N3R-83-482
3R	0.906	4.250	0.406	3.125-F	1.688	4	Round	N3R-83-627

TORQUE LIMITER

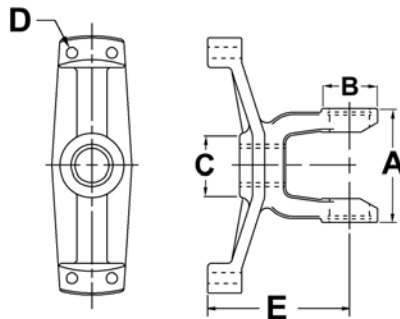

DL Series	C Bore Dia./Shape	D Hole/Thread Size	E Flange Face To CL	Number Of Bolt Holes	Part Number
2200 Series		A-3.218	B-1.250	C-2.06	
2200	1.061 Round	0.340	4.430	4	48-1181

FLANGE YOKE

Notes

FLANGE YOKE



THE DRIVELINE EXPERTS

Slip Yoke

SUB SECTION

Transmission Flange Sleeve

Sleeve

PTO Sleeve

PTO Hex Bore - Inside Lock-Up

PTO Square Bore - Inside Lock-Up

PTO Rectangular Bore - Inside Lock-Up

PTO Round Bore - Inside Lock-Up

Splined Slip Yoke - Inside Lock-Up

Splined Slip Yoke - Outside Lock-Up

AND MUCH MORE!

**Manufacturing Driveline Solutions®
in the USA Since 1921.**

NeapcoAftermarket.com

SECTION

3



SLIP YOKE

TRANSMISSION FLANGE SLEEVE

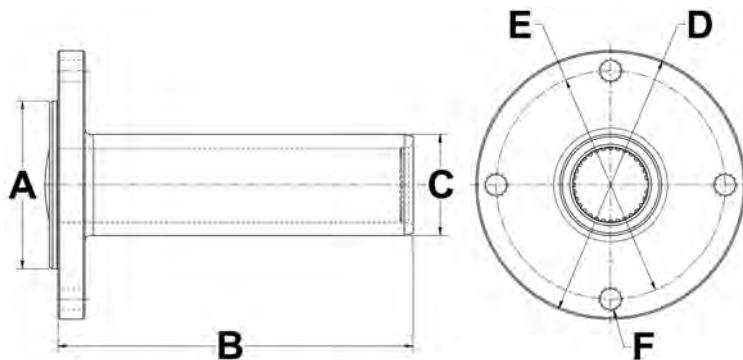

DL Series	A Pilot Dia.	Spine/Number Teeth	B Flange Face To End	C Hub Dia.	E Bolt Circle	F Hole/ Thread Size	Number Of Bolt Holes	Part Number
1310 Series								
1310	2.000-M	1.375-31/32	6.594	1.875	3.000	0.375	4	N2-23-9162X
1350 Series								
1350	3.125-M	1.375-31/32	5.656	1.891	4.250	7/16-20	4	N3-23-9168KX

SLEEVE

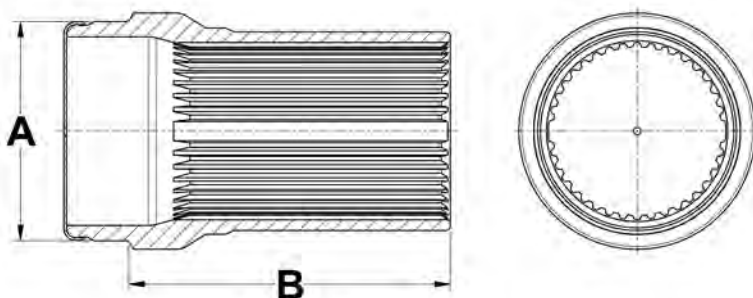

DL Series	Bore Type	A Butt Dia.	B End Of Spine To Weld	Spine/Number Teeth	Part Number
NPL170/SPL170					
NPL170/SPL170*	Round	4.351	8.000	3.465-32/34	N170-55-21-2X
NPL170/SPL170*	Round	4.344	8.000	3.465-32/34	N170-55-51-1
SPL170/250 Series					
SPL170/SPL250*	Round	4.748	6.875	3.858-38	N250-55-31X

* SPL - Spicer® Life Series driveshafts is a registered trademark of Dana Limited

PTO SLEEVE

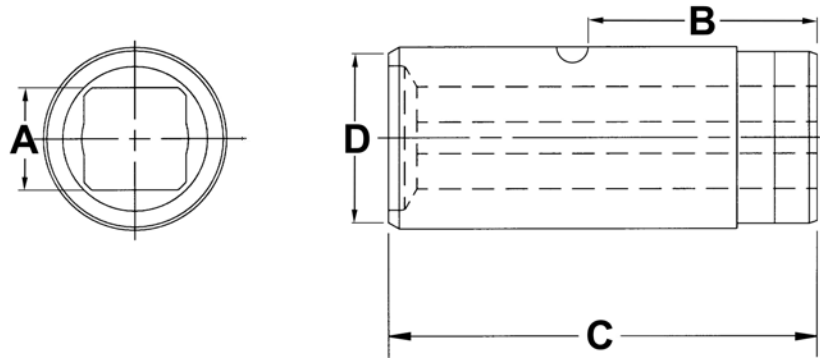

Bore Type	A Bore Size	B CL To End Of Hub	Hole/ Thread Size	C Overall Length	D Sleeve Dia.	Spline/Number Teeth	Spline Type	Part Number
Round	1.000	2.500	1/4-28	5.000	2.130	1-15 with missing tooth	Involute	53-0374
Rectangle / Round	0.751 x 0.876 / 0.877	***	***	4.000	1.630	***	***	53-0634
Rectangle / Round	0.751 x 0.876 / 0.877	***	***	4.000	***	***	***	53-0635
Rectangle / Round	1.00 x 1.130 / 1.130	***	***	5.000	2.000	***	***	53-1834
Rectangle / Round	1.000 x 1.127	2.500	1/4-28	5.000	2.130	***	***	53-2034
Round	1.630	***	0.180	6.000	2.250	1.630-10	***	53-2415
Square	1.193	2.500	1/4-28	5.000	2.130	***	***	53-2434
Square	1.193	2.500	1/4-28	5.000	2.130	***	***	53-2435
Square	1.316	***	1/4-28	5.000	2.500	***	***	53-2643
Square	1.316	***	1/4-28	5.000	2.630	***	***	53-2644
Square	1.193	2.500	1/4-28	5.000	2.130	***	***	53-3500

SLIP YOKE

PTO HEX BORE - INSIDE LOCK-UP

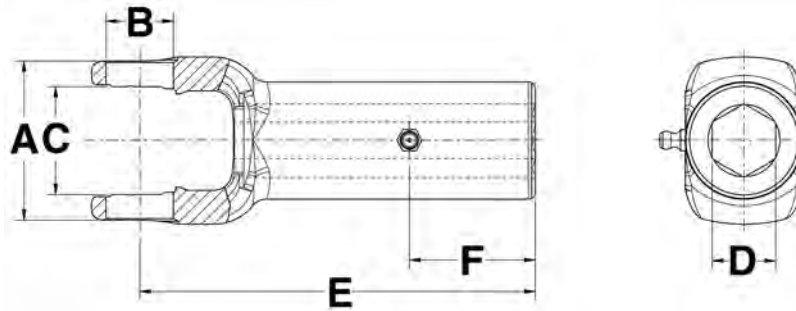

DL Series	D Bore Dia./Shape	E CL To End Of Hub	Lube Fitting Location	F Lube Fitting Distance To End Of Hub	Part Number
1000 Series A-2.312 B-0.938 C-1.500					
1000	1.125 Hexagonal	5.500	GAP	1.750	10-0332
1000	0.875 Hexagonal	5.500	GAP	1.750	10-3162

PTO SQUARE BORE - INSIDE LOCK-UP

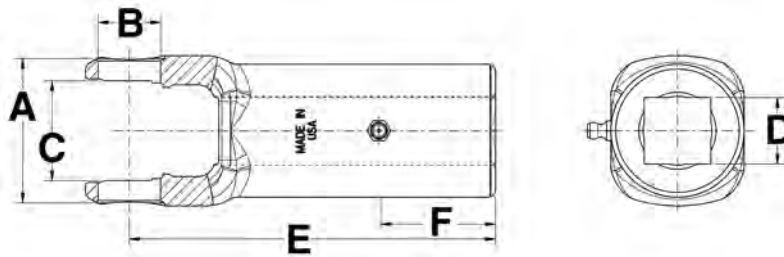

DL Series	D Bore Dia./Shape	E CL To End Of Hub	F Lube Fitting Distance To End Of Hub	Lube Fitting Location	Part Number
1000 Series A-2.312 B-0.938 C-1.500					
1000	0.750 Square	5.500	1.750	GAP	10-0312
1000	0.875 Square	5.500	1.750	GAP	10-0322
1000	0.750 Square	5.500	2.000	GAP	10-1758
1000	1.000 Square	5.500	1.750	GAP	10-3122

PTO RECTANGULAR BORE - INSIDE LOCK-UP

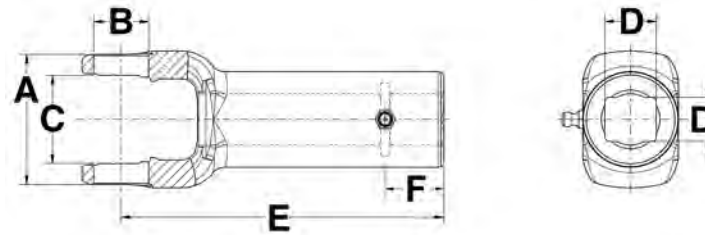

DL Series	D Bore Dia./Shape	E CL To End Of Hub	Lube Fitting Location	F Lube Fitting Distance To End Of Hub	Part Number
1000 Series		A-2.312	B-0.938	C-1.500	
1000	0.750 x 0.875 Rectangle	5.500	GAP	1.750	10-1769

PTO ROUND BORE - INSIDE LOCK-UP

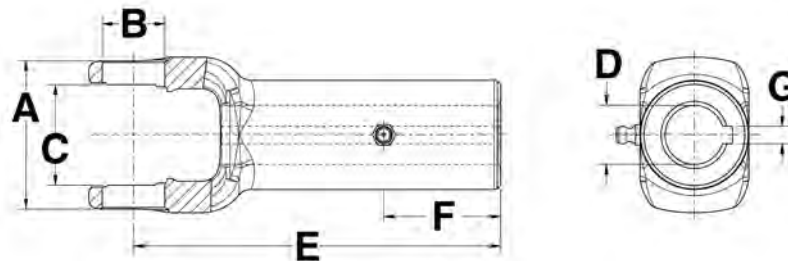

DL Series	D Bore Dia./Shape	E CL To End Of Hub	F Lube Fitting Distance To End Of Hub	G Keyway Width	Keyway Location	Lube Fitting Location	Hole/Thread Size	Part Number
1000 Series		A-2.312	B-0.938	C-1.500				
1000	0.750 Round	5.500	1.750	0.188	GAP	GAP	***	10-0313
1000	0.812 Round	5.500	1.750	0.250	GAP	GAP	***	10-0323
1000	0.875 Round	5.500	1.750	0.250	GAP	GAP	***	10-0333
1000	1.000 Round	5.500	1.750	0.250	GAP	GAP	***	10-0383
1000	1.125 Round	5.500	1.750	0.250	GAP	GAP	***	10-1767
1000	1.250 Round	5.500	1.750	0.312	GAP	GAP	***	10-3163
1000	1.250 Round	5.500	1.690	0.250	GAP	GAP	***	10-3173

SLIP YOKE

SLIP YOKE

PTO ROUND BORE - INSIDE LOCK-UP (Cont'd)

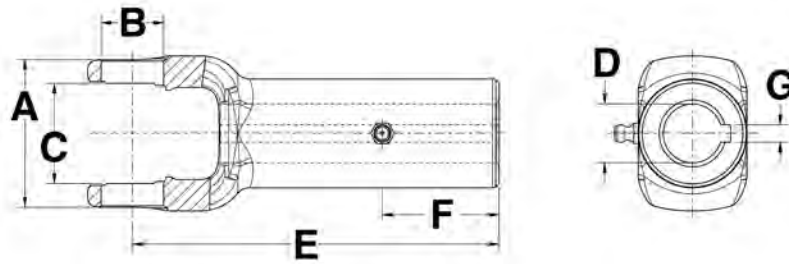

DL Series	D Bore Dia./ Shape	E CL To End Of Hub	F Lube Fitting Distance To End Of Hub	G Keyway Width	Keyway Loca- tion	Lube Fitting Location	Hole/ Thread Size	Part Number
		1000 Series			A-2.312	B-0.938	C-1.500	
1000	1.125 Round	5.500	1.750	0.312	GAP	GAP	***	10-3183
1000	0.938 Round	5.500	2.000	0.250	GAP	GAP	1-1/8 - 27	10-3203

SPLINED SLIP YOKE - INSIDE LOCK-UP

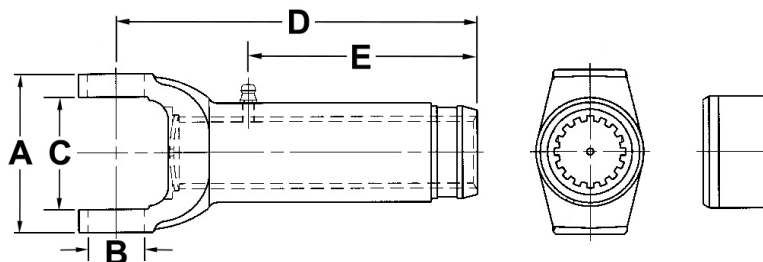

DL Series	Spline/Number Teeth	Bore Dia./Shape	D CL To End Of Hub	E Lube Fitting Dis- tance To End Of Hub	Lube Fitting Location	Part Number	
		1000 Series			A-2.312	B-0.938	C-1.500
1000	1.250-16	1.250-16 Spline	5.031	1.594	GAP	10-0318	
1000	1.250-16	1.250-16 Spline	6.281	2.375	EAR	10-0319	
1000	1.125-10	1.125-10 Spline	5.500	1.750	GAP	10-0381	
1000	1.250-6	1.250-6 Spline	5.500	2.000	GAP	10-1765	
1000	1.125-10	1.125-10 Spline	5.500	3.500	GAP	11-1075	
		1200 Series			A-2.562	B-1.063	C-1.812
1200	1.375-16	1.375-16 Spline	5.250	3.380	***	12-2322	

SPLINED SLIP YOKE - OUTSIDE LOCK-UP

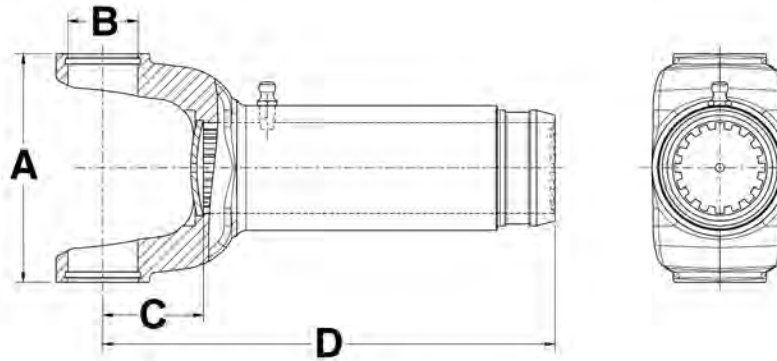

DL Series	Spline/Number Teeth	C CL To Face Washer	D CL To End Of Spline	Joint Angle	Lube Fitting Part Number	Dust Cap	Part Number
1210 Series				A-2.56	B-1.063		
1210	1.250-14/16	1.27	6.40	20	0641-B	280196	N2-3-8861KX
1210	1.250-14/16	1.27	8.02	20	0641-B	280196	N2-3-8961KX
1310 Series				A-3.469	B-1.063		
1310	1.375-16	1.05	5.38	15	0641-B	280194	N2-3-128KX
1310	1.181-22	1.43	6.56	30	***	***	N2-3-1293
1310	1.250-16	1.43	6.56	30	0641-B	ND2K	N2-3-4441KX
1310	1.375-16	1.05	6.00	20	0641-B	280195	N2-3-4951KX
1310	1.375-16	1.53	6.88	30	0641-B	280195	N2-3-5221KX
1310	1.375-16	1.53	7.88	30	0641-B	280195	N2-3-5821KX
1310	1.500-16	1.53	6.88	30	0641-B	ND3A	N2-3-6061KX
1310	1.500-16	1.53	8.09	30	0641-B	ND3K	N2-3-6071KX
1310	1.375-31/32	1.48	6.62	15	0641-B	ND3A	N2-3-7171KX
1310	1.375-16	1.05	6.00	20	0641-B	280194	N2-3-7981KX
1310	1.375-16	1.53	6.88	30	0641-B	280194	N2-3-8001KX
1310	1.375-16	1.53	7.88	30	0641-B	280194	N2-3-8021KX
1310	1.375-31/32	1.36	7.38	22	0641-B	ND3A	N2-3-9165KX
1330 Series				A-3.875	B-1.063		
1330	1.375-16	1.05	6.00	15	0641-B	280195	N2-3-4681KX
1330	1.375-15/16	1.09	6.62	15	0641-B	280194	N2-3-7681KX
1330	1.375-16	1.05	6.00	15	0641-B	280194	N2-3-7961KX
1330	1.375-16	1.09	7.50	19	0641-B	280194	N2-3-8041KX
1330	1.375-16	1.78	8.44	35	0641-B	280195	N2-3-8051KX

SLIP YOKE

SLIP YOKE

SPLINED SLIP YOKE - OUTSIDE LOCK-UP (Cont'd)

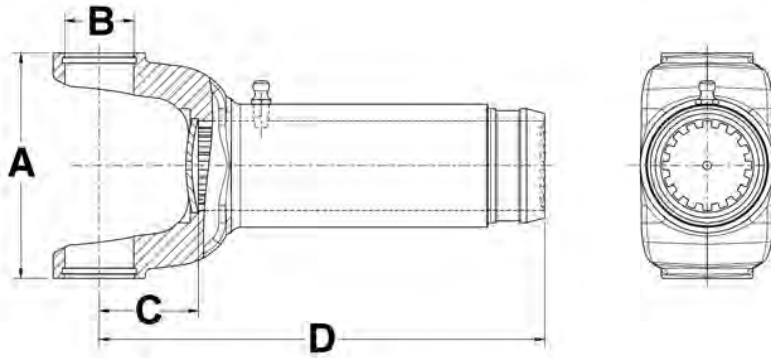

DL Series	Spline/Number Teeth	C CL To Face Washer	D CL To End Of Spline	Joint Angle	Lube Fitting Part Number	Dust Cap	Part Number
1350 Series				A-3.622	B-1.188		
1350	1.375-16	1.24	5.81	15	0641-B	280195	N3-3-1501KX
1350	1.375-16	1.24	7.31	20	0641-B	280195	N3-3-1502KX
1350	1.500-16	1.22	6.72	20	0641-B	ND3A	N3-3-1561KX
1350HR Series				A-3.622	B-1.188		
1350	1.375-31/32	1.23	6.62	20	0641-B	ND3A	N3-3-2471KX
1350	1.375-15/16	1.22	6.81	20	0641-B	280194-1	N3-3-2701KX
1350	1.500-16	1.24	7.31	20	0641-B	ND3A	N3-3-488KX
1350	1.500-16	1.24	5.81	20	0641-B	ND3A	N3-3-598KX
1350	1.375-16	1.28	5.19	15	0641-B	280195	N3-3-758KX
1350	1.500-16	1.78	8.44	35	0641-B	ND3K	N3-3-8081KX
1410 Series				A-4.438	B-1.188		
1410	1.500-16	1.18	6.50	20	0641-B	ND3A	N3-3-118KX
1410	1.375-16	1.18	5.81	20	0641-B	280195	N3-3-1481KX
1410	1.500-16	1.18	5.25	20	0641-B	ND3K	N3-3-2041KX
1410	1.500-16	1.31	7.81	28	0641-B	ND3A	N3-3-508KX
1410	1.375-16	1.18	5.25	20	0641-B	280195	N3-3-788KX
1480 Series				A-4.438	B-1.375		
1480	1.562-16	1.36	6.81	21	0641-B	ND3H	N3-3-1601KX
1480	1.562-16	2.00	9.50	35	0641-B	ND3H	N3-3-1641KX
1550HR Series				A-4.965	B-1.375		
1550	1.750-16	1.88	6.88	22	0641-B	ND4J	N4-3-1241KX
1550	1.750-16	1.38	8.12	22	0641-B	ND4J	N4-3-1411KX

TRANSMISSION INSIDE LOCK-UP

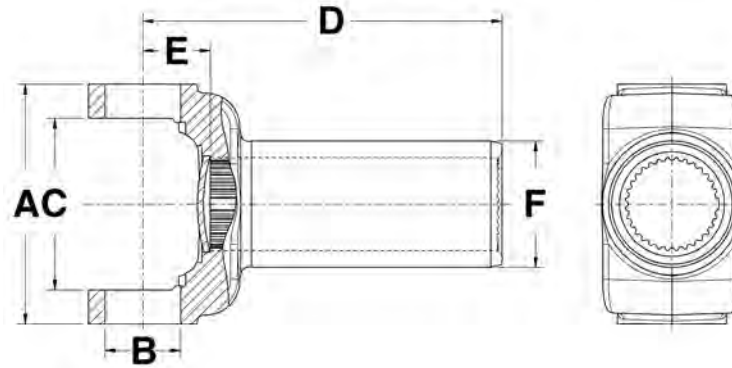

DL Series	Spine/Number Teeth	D CL To End Of Spine	E CL To Face Washer	F Seal Dia.	Joint Angle	Spine Type	Part Number
3R Series A-3.563 B-1.125 C-2.563							
3R	1.172-26/27	6.750	***	1.500	***	Counter Bore	N3R-3-12051X
3R	1.172-26/27	5.469	***	1.500	***	Full Spine	N3R-3-12361X
3R	1.172-26/27	6.750	***	1.500	***	Full Spine	N3R-3-1658X
3R	1.172-26/27	5.469	0.875	1.500	***	Full Spine	N3R-3-6081X
3R	1.391-31/32	8.062	1.359	1.875	22.0	Full Spine	N3R-3-9101X
3R	1.391-31/32	7.500	1.000	1.875	15.0	Counter Bore	N3R-3-9131X
3R	1.391-31/32	7.500	1.000	1.875	15.0	Full Spine	N3R-3-9161X
3R	1.391-31/32	5.344	1.000	1.875	15.0	Full Spine	N3R-3-9762X
3R	1.391-31/32	7.500	***	1.875	***	Full Spine	NT3R-3-9161HP
7290 Series A-3.563 B-1.126 C-2.625							
7290	1.312-29/30	7.562	1.000	1.875	15.0	Counter Bore	N729-3-1932X

SLIP YOKE

SLIP YOKE

TRANSMISSION OUTSIDE LOCK-UP

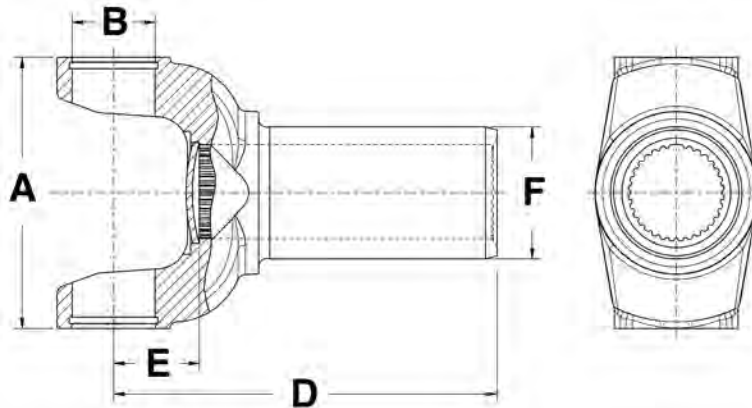

DL Series	Spline/Number Teeth	D CL To End Of Spline	E CL To Face Washer	F Seal Dia.	Joint Angle	Spline Type	Part Number
1310 Series A-3.469 B-1.063							
1310	1.391-31/32	5.500	1.000	1.875	15.0	Counter Bore	N2-3-10431X
1310	1.219-27/28	7.031	1.000	1.500	15.0	Full Spline	N2-3-12671X
1310	1.390-30/31	7.000	1.531	1.688	30.0	Full Spline	N2-3-15631X
1310	1.312-29/30	8.062	1.359	1.688	22.0	Counter Bore	N2-3-3575X
1310	1.219-27/28	6.031	1.047	1.500	20.0	Full Spline	N2-3-4871X
1310	1.172-26/27	5.469	0.906	1.500	***	Full Spline	N2-3-6081X
1310	1.219-27/28	6.531	1.000	1.500	15.0	Full Spline	N2-3-8251X
1310	1.391-31/32	8.062	1.359	1.875	22.0	Full Spline	N2-3-9101X
1310	1.391-31/32	7.500	1.000	1.875	15.0	Counter Bore	N2-3-9131X
1310	1.391-31/32	7.500	1.000	1.885	15.0	Full Spline	N2-3-9161X
1310	1.391-31/32	5.500	***	1.875	***	Full Spline	NT2-3-10431HP
1310	1.391-31/32	4.875	***	1.875	***	Full Spline	NT2-3-13131HP
1310	1.219-27/28	6.000	***	1.500	***	Full Spline	NT2-3-4871HP
1310	1.172-26/27	4.875	***	1.500	***	Full Spline	NT2-3-4911HP
1310	1.172-26/27	5.469	***	1.500	***	Full Spline	NT2-3-6081HP
1310	1.172-26/27	8.000	***	1.500	***	Full Spline	NT2-3-6081HP8XL
1310	1.219-27/28	6.500	***	1.500	***	Full Spline	NT2-3-8251HP
1330 Series A-3.875 B-1.063							
1330	1.390-30/31	7.031	1.094	1.875	19.0	Full Spline	N2-3-10201X
1330	1.219-27/28	6.656	1.047	1.594	15.0	Full Spline	N2-3-14061X
1330	1.219-27/28	5.969	1.047	1.500	15.0	Full Spline	N2-3-5981X
1330	1.390-30/31	6.031	1.047	1.688	15.0	Full Spline	N2-3-6041X
1330	1.378-31/32	6.766	***	1.875	***	Full Spline	NT2-3-10831HP
1330	1.172-26/27	6.766	***	1.500	***	Counter Bore	NT2-3-12051HP

TRANSMISSION OUTSIDE LOCK-UP (Cont'd)

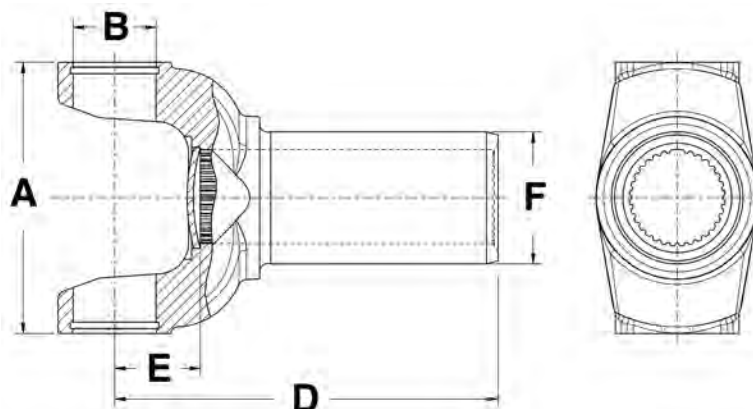

DL Series	Spline/Number Teeth	D CL To End Of Spline	E CL To Face Washer	F Seal Dia.	Joint Angle	Spline Type	Part Number
1330 Series					A-3.875	B-1.063	
1330	1.172-26/27	5.469	***	1.500	***	Full Spline	NT2-3-12081HP
1330	1.219-27/28	6.625	***	1.600	***	Full Spline	NT2-3-14061HP
1330	1.219-27/28	5.906	***	1.500	***	Full Spline	NT2-3-5981HP
1330	1.390-30/31	6.000	***	1.680	***	Full Spline	NT2-3-6041HP
1350 Series					A-3.875	B-1.188	
1350	1.219-27/28	6.750	1.172	1.594	20.0	Full Spline	N3-3-14061X
1350	1.375-31/32	5.500	1.234	1.875	15.0	Counter Bore	N3-3-2431X
1350	1.390-30/31	6.500	1.219	1.688	20.0	Full Spline	N3-3-2491X
1350	1.378-31/32	6.938	1.312	1.891	***	Full Spline	N3-3-4261X
1350	1.172-26/27	5.938	1.188	1.500	20.0	Full Spline	N3-3-4271X
1350	1.172-26/27	6.938	1.188	1.500	***	Counter Bore	N3-3-4281X
1350	1.390-30/31	7.344	0.906	1.875	20.0	Full Spline	N3-3-5431X
1350	1.378-31/32	7.875	1.312	1.891	***	Full Spline	N3-3-9467X
1350	1.219-27/28	6.625	***	1.594	***	Full Spline	NT3-3-14061HP
1350	1.378-31/32	5.500	***	1.875	***	Counter Bore	NT3-3-2431CBHP
1350	1.378-31/32	5.500	***	1.875	***	Full Spline	NT3-3-2431HP
1350	1.390-30/31	6.438	***	1.688	***	Full Spline	NT3-3-2491HP
1350	1.172-26/27	6.938	***	1.500	***	Counter Bore	NT3-3-4281HP
1350	1.390-30/31	7.312	***	1.875	***	Full Spline	NT3-3-5431HP
1350	1.378-31/32	7.938	***	1.875	***	Counter Bore	NT3-3-5551HP
1350	1.378-31/32	6.938	***	1.875	***	Full Spline	NT3-3-5571HP
1350	1.172-26/27	5.469	***	1.500	***	Full Spline	NT3-3-6081HP
1350	1.219-27/28	6.500	***	1.500	***	Full Spline	NT3-3-8251HP
1480 Series					A-4.438	B-1.375	
1480	1.390-30/31	6.906	1.359	1.875	21.0	Full Spline	N3-3-6021X

SLIP YOKE

SLIP YOKE

BEARING PLATE CONSTRUCTION

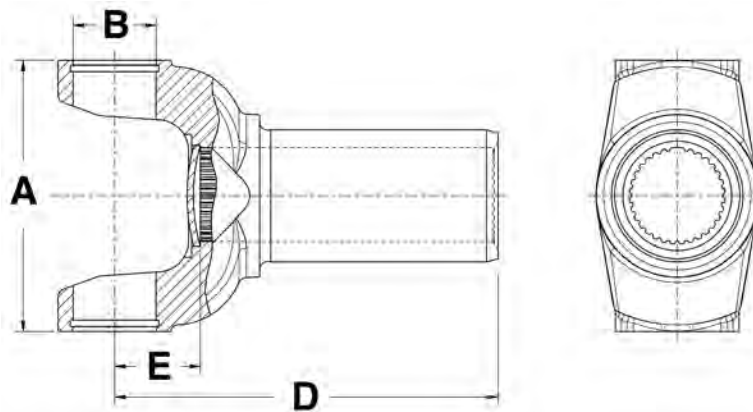

DL Series	Spine/ Number Teeth	D CL to End of Spine	E CL To Face Washer	Joint Angle	Lube Fitting Part Number	Dust Cap	Part Number
1610 Series				A-5.321	B-1.875		
1610	2.000-16	10.81	3.19	35.0	0610-B	N5-86-68	N5-3-2261KX
1610	2.000-16	9.31	3.19	30.0	0610-B	N5-86-68	N5-3-288KX
1610	2.000-16	8.88	2.69	35.0	0610-B	N5-86-68	N5-3-368KX
1710 Series				A-6.094	B-1.938		
1710	2.500-16	11.69	2.44	30.0	0610-B	N6.3-86-18	N6-3-2651KX
1710	2.500-16	9.59	1.72	22.0	0610-B	N6.3-86-18	N6-3-2671KX
1710	2.500-16	12.72	3.11	45.0	0610-B	N6.3-86-18	N6-3-3441KX
1760 Series				A-7.000	B-1.938		
1760	2.500-16	11.16	2.47	30.0	0610-B	N6.3-86-18	N6.3-3-21KX
1760	2.500-16	9.25	2.92	30.0	0610-B	N6.3-86-18	N6.3-3-41KX
1810 Series				A-7.547	B-1.938		
1810	3.000-16	10.25	2.38	30.0	0610-B	N6.5-86-38	N6.5-3-1351KX
1810	3.000-16	11.88	2.38	30.0	0610-B	N6.5-86-38	N6.5-3-1371KX
20R Series				A-4.438	B-1.375		
20R	2.500-16	11.45	2.92	32.0	***	***	N20RLS40-2A1S
20R	2.500-16	12.05	3.52	44.0	***	***	N20RLS40-3A1S
20R	2.500-16	11.45	2.92	32.0	***	***	N20RPL-SLIP
25R Series				A-8.375	B-2.062		
25R	3.000-16	11.28	2.75	22.0	***	***	N25RLS48-1A1S
25R	3.000-16	11.28	2.75	22.0	***	***	N25RPL-SLIP

SLIP YOKE

SPLINED - INSIDE LOCK-UP

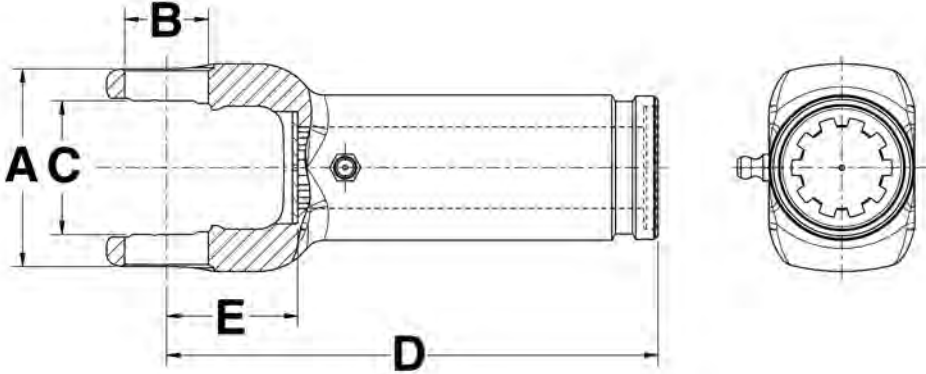

DL Series	Spline/Number Teeth	D CL to End of Spline	E CL to Face of Washer	Joint Angle	Lube Fitting Part Number	Dust Cap	Part Number
3R Series A-3.563 B-1.125 C-2.563							
3R	1.375-31/32	7.38	1.36	22.0	0641-B	ND3A	N3R-3-9165KX
3R	1.375-16	7.38	1.36	22.0	0641-B	280194	N3R-3-9170KX
7260 Series A-3.000 B-1.078 C-2.125							
7260	1.375-16	6.88	1.20	18.0	0641-B	280194	N2-3-7260KX
7290 Series A-3.563 B-1.126 C-2.625							
7290	1.375-16	6.62	1.00	15.0	0641-B	280194	N729-3-1631KX

SLIP YOKE

SLIP YOKE

Notes



THE DRIVELINE EXPERTS

End Yoke

SUB SECTION

PTO hex bore - inside lock-up

PTO square bore - inside lock-up

PTO rectangular bore - inside lock-up

PTO round bore - inside lock-up

PTO round bore - outside lock-up

PTO round bore - u-bolt

PTO round bore - weld yoke

PTO splined bore - inside lock-up

PTO splined bore - outside lock-up

AND MUCH MORE!

**Manufacturing Driveline Solutions®
in the USA Since 1921.**

NeapcoAftermarket.com

SECTION

4



END YOKE

PTO HEX BORE - INSIDE LOCK-UP

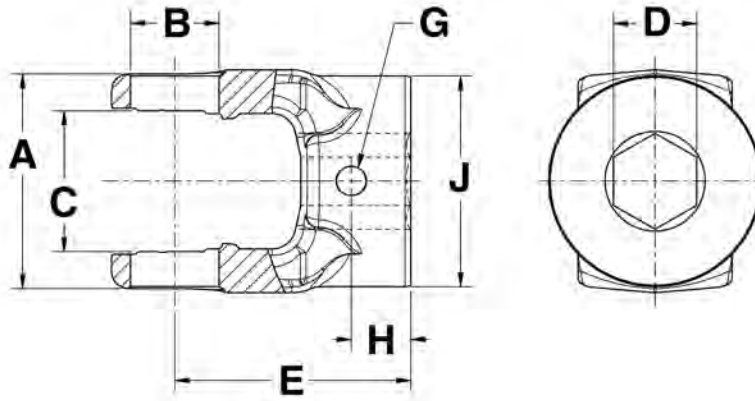

DL Series	D Bore Dia./Shape	E CL To End Of Hub	G Set Screw Hole Size	Set Screw Location	H End Of Hub To Set Screw	J Hub Dia.	Part Number
		1000 Series	A-2.312	B-0.938	C-1.500		
1000	1.127 Hexagonal	2.500	3/8-16	GAP	0.625	2.250	10-0432
1000	0.875 Hexagonal	2.500	3/8-16	GAP	0.625	2.250	10-4282
		1200 Series	A-2.562	B-1.063	C-1.812		
1200	1.127 Hexagonal	2.730	3/8-16	GAP	0.625	***	12-1168
1200	1.127 Hexagonal	5.250	1/8-27 NPT	GAP	1.750	***	12-1173
1200	1.127 Hexagonal	3.500	3/8-16	GAP	0.880	***	12-1328
		1800	B-1.00	C-2.34			
1800	1.127 Hexagonal	3.750	3/8-16	GAP	0.880	***	18-7128
		2200 Series	A-3.218	B-1.250	C-2.06		
2200	1.250 Hexagonal	3.010	.0520 (2)	***	0.560	***	22-1724

PTO SQUARE BORE - INSIDE LOCK-UP

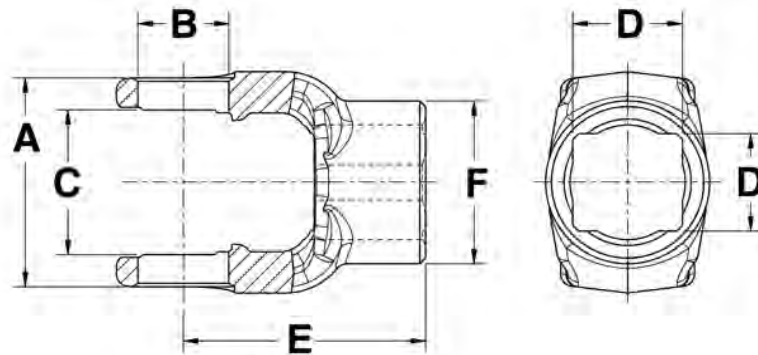

DL Series	D Bore Dia./ Shape	E CL To End Of Hub	Set Screw Hole Size	Set Screw Location	End Of Hub To Set Screw	F Hub Dia.	Part Number
1000 Series A-2.312 B-0.938 C-1.500							
1000	0.875 Square	2.500	3/8-16	GAP	0.625	1.625	10-0412
1000	0.750 Square	2.500	3/8-16	GAP	0.625	1.625	10-0422
1000	1.000 Square	2.500	3/8-16	GAP	0.625	2.250	10-0452
1000	1.1875 Square	2.500	***	***	***	2.250	10-1557
1000	1.000 Square	2.500	3/8-16	GAP	0.500	2.250	10-1580
1000	0.750 Square	1.688	3/8-16	GAP	0.375	1.630	10-5354
1200 Series A-2.562 B-1.063 C-1.812							
1200	1.125 Square	3.500	0.390 (Pin)	GAP	0.625	***	12-1148
1200	1.000 Square	3.500	3/8-16	GAP	0.880	***	12-1301
1200	1.000 Square	5.250	1/8-27 NPT	GAP	1.750	***	12-1314
1200	1.250 Square	2.750	0.340 (Pin)	GAP	0.625	***	12-1321
1800 B-1.00 C-2.34							
1800	1.000 Square	3.630	***	***	***	***	18-7125
1800	1.250 Square	3.250	***	***	***	***	18-7127
2000 Series A-2.625 B-1.125 C-1.85							
2000	1.250 Square	3.560	3/8-16	GAP	0.750	***	20-9127
2000	1.125 Square	3.750	3/8-16	GAP	0.880	***	20-9183
2000	1.000 Square	3.750	3/8-16	GAP	0.880	***	20-9310
2200 Series A-3.218 B-1.250 C-2.06							
2000	1.187 Square	3.120	***	***	***	***	20-9312
2200	1.126 Square	4.190	3/8-16	Ear	0.880	***	22-1124
2200	1.000 Square	4.190	3/8-16	Ear	0.880	***	22-1125
2200	1.1875 Square	4.470	0.403	GAP	0.340	***	22-1190
2200	1.187 Square	3.630	***	***	***	2.250	22-1344
2600 Series B-1.37 C-2.81							
2600	1.310 Square	4.630	***	***	***	3.140	26-5148

END YOKE

END YOKE

PTO SQUARE BORE - INSIDE LOCK-UP (Cont'd)

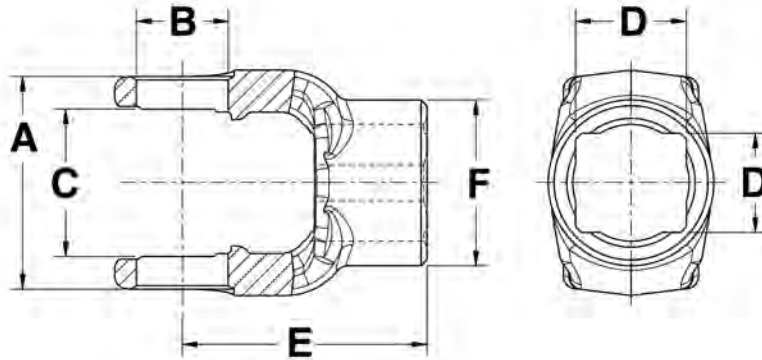

DL Series	D Bore Dia./ Shape	E CL To End Of Hub	Set Screw Hole Size	Set Screw Location	End Of Hub To Set Screw	F Hub Dia.	Part Number
N44 Series			B-1.31	C-2.79			
N44	1.126 Square	4.120	3/8-16	GAP	0.880	***	44-1826
N44	1.310 Square	4.120	***	***	***	2.860	44-2100
N55 Series			A-4.44	B-1.53			
N55	1.310 Square	4.130	***	***	***	***	55-2130

PTO RECTANGULAR BORE - INSIDE LOCK-UP

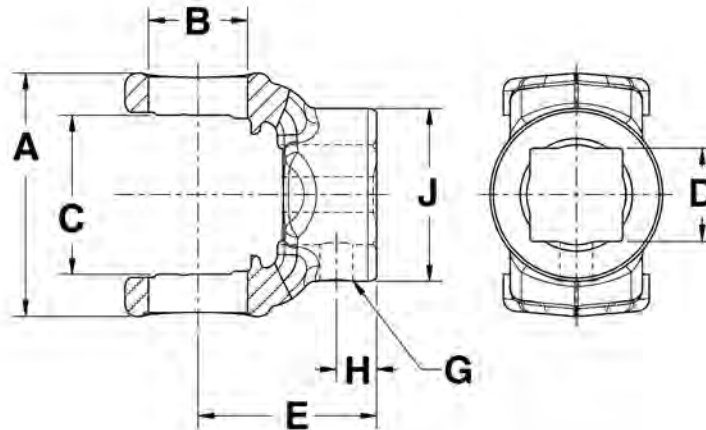

DL Series	D Bore Dia./Shape	E CL To End Of Hub	G Set Screw Hole Size	Set Screw Location	H End Of Hub To Set Screw	J Hub Dia.	Part Number
1000 Series			A-2.312 B-0.938 C-1.500				
1000	1.00 x 1.13 Rectangle	2.500	***	***	***	2.250	10-1559
1000	0.875 x 0.750 Rectangle	2.500	***	***	***	1.500	10-5129
1000	1.000 x 1.125 Rectangle	2.750	***	***	***	1.500	10-5131
1200 Series			A-2.562 B-1.063 C-1.812				
1200	1.000 x 1.125 Rectangle	3.500	0.390 (Pin)	GAP	1.000	***	12-1197
1200	1.281 x 1.408 Rectangle	2.940	***	***	***	2.250	12-1318
1200	1.000 x 1.125 Rectangle	2.940	***	***	***	2.250	12-1340
1800			B-1.00 C-2.34				
1800	1.00 x 1.128 Rectangle	3.250	***	***	***	2.000	18-7195
1800	1.000 x 1.125 Rectangle	3.375	***	***	***	2.245	18-7327
1800	1.281 x 1.408 Rectangle	3.375	***	***	***	2.245	18-7328
1800	1.000 x 1.125 Rectangle	3.125	***	***	***	2.250	18-7478

END YOKE

END YOKE

PTO ROUND BORE - INSIDE LOCK-UP

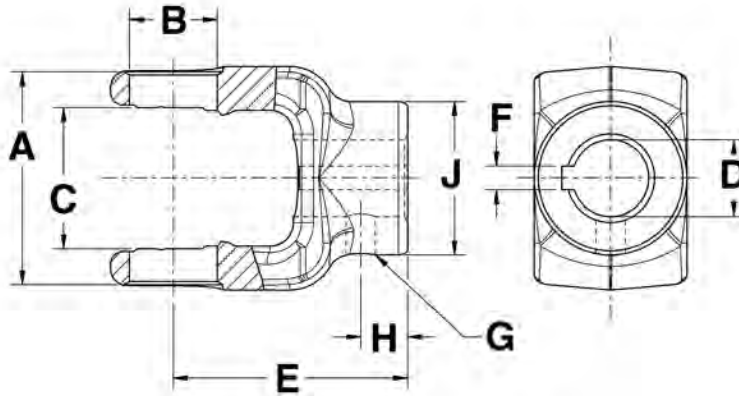

DL Series	D Bore Dia./ Shape	E CL To End Of Hub	F Keyway Width	Keyway Loca- tion	G Set Screw Hole Size	Set Screw Location	H Set Screw To End Of Hub	J Hub Dia.	Part Number
1000 Series A-2.312 B-0.938 C-1.500									
1000	0.750 Round	2.500	0.188	GAP	3/8-16	GAP	0.625	1.625	10-0413
1000	0.750 Round	2.500	0.250	GAP	3/8-16	GAP	0.625	1.625	10-0423
1000	0.812 Round	2.500	0.250	GAP	3/8-16	GAP	0.625	1.625	10-0443
1000	0.875 Round	2.500	0.188	GAP	3/8-16	GAP	0.625	1.625	10-0453
1000	0.875 Round	2.500	0.250	GAP	3/8-16	GAP	0.625	1.625	10-0463
1000	0.938 Round	2.500	0.250	GAP	3/8-16	GAP	0.625	1.625	10-0473
1000	1.000 Round	2.500	0.188	GAP	3/8-16	GAP	0.625	1.625	10-0483
1000	1.000 Round	2.500	0.250	GAP	3/8-16	GAP	0.625	1.625	10-0493
1000	1.500 Round	2.500	***	***	0.281 DT (2)	GAP	0.500	2.000	10-1532
1000	1.1875 Round	2.500	0.250 / 0.312	GAP	3/8-16	GAP	0.625	2.250	10-1574
1000	0.875 Round	1.688	0.250	GAP	3/8-16	GAP	0.375	1.630	10-1703
1000	1.000 Round	1.688	0.250	GAP	3/8-16	GAP	0.438	1.625	10-1705
1000	1.125 Round	2.500	0.250	GAP	3/8-16	GAP	0.625	2.250	10-4103
1000	1.125 Round	2.500	0.312	GAP	3/8-16	GAP	0.625	2.250	10-4113
1000	1.250 Round	2.500	0.312	GAP	3/8-16	EAR/GAP	0.500	2.250	10-4123
1000	0.750 Round	2.500	0.188	GAP	3/8-16 (2)	GAP	0.625	1.625	10-4133
1000	1.125 Round	2.500	0.250	GAP	3/8-16	GAP	0.625	2.250	10-4143
1000	1.1875 Round	2.500	0.312	GAP	3/8-16	GAP	0.625	2.250	10-4153
1000	1.062 Round	2.500	0.250	GAP	3/8-16	GAP	0.625	2.250	10-4163
1000	0.812 Round	2.500	0.250	GAP	3/8-16	GAP	0.625	1.625	10-4173
1000	1.250 Round	2.500	0.250	GAP	3/8-16	GAP	0.500	2.250	10-4183
1000	1.250 Round	2.500	0.312	GAP	3/8-16	GAP	0.625	2.250	10-4193
1000	1.375 Round	2.500	0.312	GAP	3/8-16	GAP	0.625	2.000	10-4293
1000	1.250 Round	2.500	***	***	0.375 DT (2)	GAP	0.625	2.250	10-4363
1000	0.625 Round	2.500	0.188	GAP	3/8-16	GAP	0.625	1.625	10-4373

PTO ROUND BORE - INSIDE LOCK-UP (Cont'd)

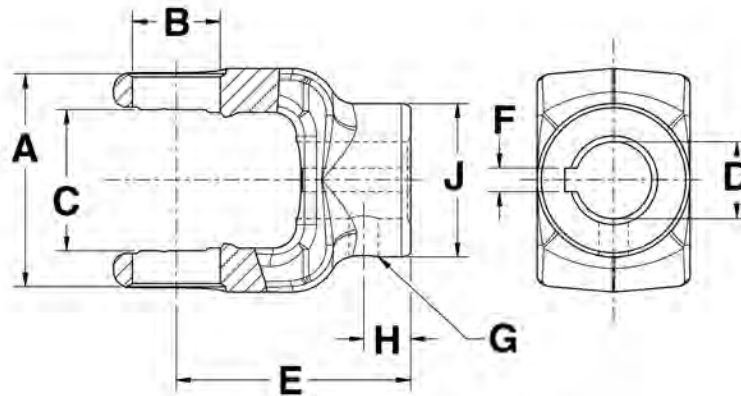

DL Series	D Bore Dia./ Shape	E CL To End Of Hub	F Keyway Width	Keyway Loca- tion	G Set Screw Hole Size	Set Screw Location	H Set Screw To End Of Hub	J Hub Dia.	Part Number
1000 Series A-2.312 B-0.938 C-1.500									
1000	1.000 Round	2.500	***	***	0.375 DT (2)	GAP	0.625	1.625	10-4443
1000	0.875 Round	2.500	0.250	GAP	3/8-16	GAP	0.625	1.625	10-4453
1000	1.125 Round	2.500	0.312	GAP	3/8-16	GAP	0.625	2.250	10-4473
1000	1.000 Round	2.500	0.251	GAP	3/8-16 UNC 2B	GAP	0.500	2.000	10-4493
1000	1.000 Round	2.500	0.250	GAP	3/8-16	GAP	0.625	1.625	10-4573
1000	0.750 Round	1.688	0.188	GAP	3/8-16	GAP	0.438	1.625	10-4693
1000	0.875 Round	1.688	0.250	GAP	3/8-16	GAP	0.438	1.625	10-4703
1000	0.875 Round	2.500	0.189	GAP	3/8-16	GAP	0.500	1.630	10-4943
1000	1.1875 Round	3.000	***	***	***	***	***	1.500	10-5132
1000	1.250 Round	2.500	0.251	GAP	3/8-16 (2)	EAR/GAP	0.500	2.250	10-5156
1000	1.244 Round	2.500	***	***	***	***	***	1.630	10-5174
1000	1.125 Round	2.500	0.251	GAP	3/8-16 UNC 2B	EAR	0.500	2.250	10-5198
1000	0.875 Round	2.500	0.250 / 0.189	(2) GAP	3/8-16	GAP	0.500	1.630	10-5213
1000	1.000 Round	2.500	0.250 / 0.189	(2) GAP	3/8-16	GAP	0.500	1.630	10-5215
1000	1.250 Round	2.500	0.310 / 0.250	(2) GAP	3/8-16	GAP	0.500	***	10-5216
1000	1.375 Round	2.500	0.310 / 0.250	(2) GAP	3/8-16	GAP	0.500	2.250	10-5218
1000	1.125 Round	1.688	0.250	GAP	3/8-16	GAP	0.375	1.630	10-5274
1000	1.000 Round	2.750	0.250	EAR	3/8-16	GAP	0.625	***	10-5322
1000	1.000 Round	2.500	***	***	***	***	***	2.250	10-5425
1200 Series A-2.562 B-1.063 C-1.812									
1200	0.875 Round	3.500	0.250	EAR	3/8-16	GAP	0.880	***	12-1113
1200	1.375 Round	3.500	0.310	EAR	3/8-16	GAP	0.880	***	12-1120
1200	0.875 Round	2.750	0.250	EAR	3/8-16	GAP	0.625	***	12-1133
1200	1.250 Round	5.250	0.313	EAR	1/8-27 NPT	GAP	1.750	***	12-1174
1200	1.500 Round	2.750	0.376	GAP	3/8-16	GAP	0.625	***	12-1175

END YOKE

END YOKE

PTO ROUND BORE - INSIDE LOCK-UP (Cont'd)

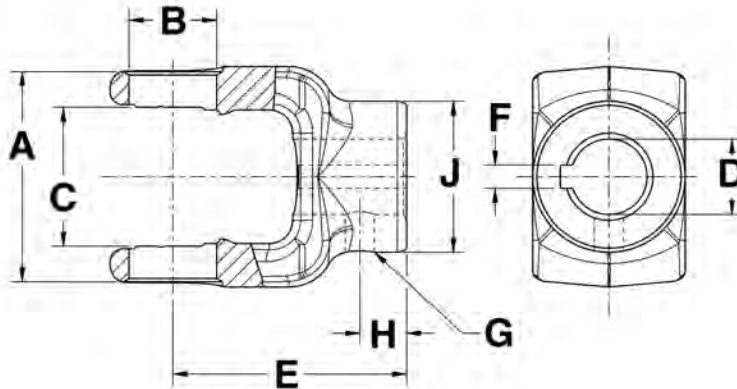

DL Series	D Bore Dia./ Shape	E CL To End Of Hub	F Keyway Width	Keyway Loca- tion	G Set Screw Hole Size	Set Screw Location	H Set Screw To End Of Hub	J Hub Dia.	Part Number
1200 Series A-2.562 B-1.063 C-1.812									
1200	1.000 Round	3.500	0.250 / 0.250	(2) EAR	3/8-16	GAP	0.880	***	12-1215
1200	1.125 Round	3.500	0.251/0.313	(2) EAR	3/8-16 UNC 2B	GAP	0.880	***	12-1216
1200	1.250 Round	3.500	0.310 / 0.250	(2) EAR	3/8-16	GAP	0.880	***	12-1218
1200	1.000 Round	3.000	0.251	EAR	M10 x 1.5 6H	GAP	0.750	***	12-1269
1200	0.750 Round	2.750	0.188	EAR	3/8-16	GAP	0.625	***	12-1312
1200	1.000 Round	5.250	0.251	EAR	1/8-27 NPT	GAP	1.750	***	12-1316
1200	1.000 Round	3.000	***	***	0.325 (Pin)	GAP	0.625	***	12-1319
1200	1.375 Round	3.250	***	***	0.528 (Pin)	GAP	0.500	***	12-1320
1200	1.000 Round	3.310	0.251	EAR	.413 (thru hole)	GAP	0.690	***	12-1323
1200	1.250 Round	3.000	***	***	0.387 (Pin)	GAP	0.625	***	12-1330
1200	1.500 Round	3.750	***	***	***	***	***	1.840	12-1334
1200	1.250 Round	2.750	0.250	GAP	3/8-16	GAP	0.625	***	12-1345
1200	1.4375 Round	3.000	0.376	GAP	3/8-16 UNC 2B	EAR	0.670	***	12-1419
1200	1.250 Round	3.310	0.3135	EAR	0.513 (Thru hole)	***	0.690	***	12-1605
1800 B-1.00 C-2.34									
1800	1.000 Round	3.750	0.250	EAR	3/8-16	GAP	0.880	***	18-7115
1800	1.125 Round	3.750	0.3135	EAR	3/8-16	GAP	0.880	***	18-7117
1800	1.1875 Round	3.750	0.3135	EAR	3/8-16	GAP	0.880	***	18-7118
1800	1.250 Round	3.750	0.3135	EAR	3/8-16	GAP	0.880	***	18-7119
1800	1.375 Round	3.750	0.3135	EAR	3/8-16	GAP	0.880	***	18-7120
1800	1.500 Round	3.500	***	***	***	***	***	1.842	18-7305
1800	1.191 Square	3.750	***	***	***	***	***	1.850	18-7308
1800	1.375 Round	3.500	***	***	0.528 (Pin)	GAP	0.500	***	18-7315

PTO ROUND BORE - INSIDE LOCK-UP (Cont'd)

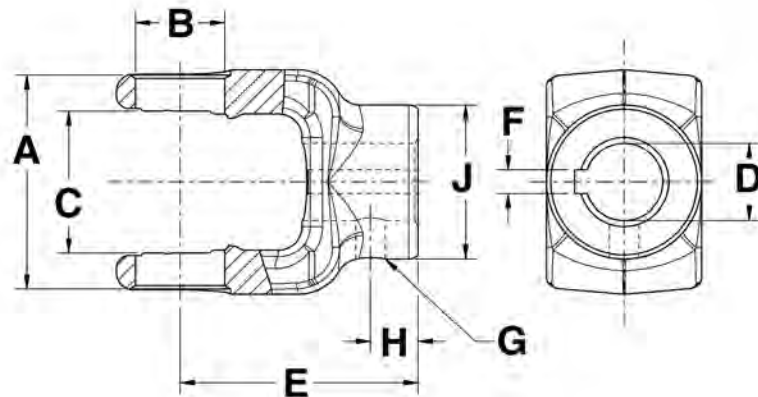

DL Series	D Bore Dia./ Shape	E CL To End Of Hub	F Keyway Width	Keyway Loca- tion	G Set Screw Hole Size	Set Screw Location	H Set Screw To End Of Hub	J Hub Dia.	Part Number
2000 Series A-2.625 B-1.125 C-1.85									
2000	1.000 Round	3.750	0.250	EAR	3/8-16	GAP	0.880	***	20-9115
2000	1.375 Round	3.750	0.313	EAR	3/8-16 (2)	EAR/GAP	0.880	***	20-9120
2000	1.4375 Round	3.750	0.376	EAR	3/8-16	GAP	0.880	***	20-9154
2000	1.375 Round	3.500	***	***	0.528	GAP	0.500	***	20-9160
2000	1.375 Round	3.750	***	***	0.435	GAP	0.810	***	20-9189
2000	1.125 Round	3.750	(2) .251, .313	EAR	3/8-16	GAP	0.880	***	20-9216
2000	1.1875 Round	3.750	(2) .251, .313	EAR	3/8-16	GAP	0.880	***	20-9217
2000	1.250 Round	3.750	(2) .251, .313	EAR	3/8-16	GAP	0.880	***	20-9218
2000	1.500 Round	3.750	0.376	EAR	3/8-16	GAP	0.880	***	20-9307
2000	1.250 Round	3.750	***	***	0.247	GAP	0.880	***	20-9317
2000	1.125 Round	3.750	***	***	0.247	GAP	0.880	***	20-9318
2000	1.500 Round	3.750	***	***	0.247	GAP	0.880	***	20-9320
2200 Series A-3.218 B-1.250 C-2.06									
2200	1.500 Round	4.190	0.376	EAR	3/8-16	GAP	0.880	***	22-1120
2200	1.1875 Round	4.190	0.251	EAR	3/8-16	GAP	0.880	***	22-1129
2200	1.000 Round	4.190	0.251	EAR	3/8-16	GAP	0.880	***	22-1131
2200	1.125 Round	4.190	0.251	EAR	3/8-16	GAP	0.880	***	22-1132
2200	1.250 Round	4.190	***	***	0.247	GAP	0.880	***	22-1145
2200	1.500 Round	4.190	0.376	EAR	3/8-16 (2)	Gap, Ear	0.880	***	22-1154
2200	1.500 Round	4.190	***	***	0.497	GAP	0.690	***	22-1162
2200	1.440 Round	4.190	0.376	EAR	3/8-16	Ear	1.000	***	22-1178
2200	1.250 Round	4.190	0.251, 0.313	EAR	3/8-16	GAP	0.880	***	22-1218
2200	1.375 Round	4.190	0.376, 0.313	EAR	3/8-16	GAP	0.880	***	22-1219
2200	1.750 Round	4.380	0.376	EAR	0.266	Gap	1.380	***	22-1316
2200	1.375 Round	4.190	***	***	0.523	Gap	0.750	***	22-1337
2200	1.625 Round	4.380	0.376	EAR	3/8-16	Ear	0.630	***	22-1338

END YOKE

END YOKE

PTO ROUND BORE - INSIDE LOCK-UP (Cont'd)

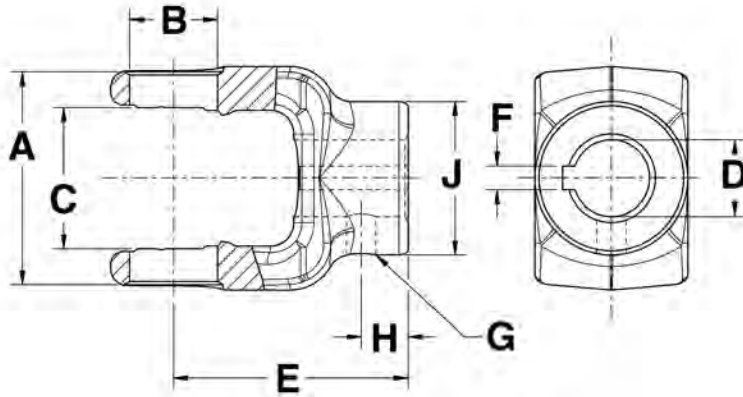

DL Series	D Bore Dia./ Shape	E CL To End Of Hub	F Keyway Width	Keyway Loca- tion	G Set Screw Hole Size	Set Screw Location	H Set Screw To End Of Hub	J Hub Dia.	Part Number
2600 Series		B-1.37 C-2.81							
2600	1.380 Round	4.500	0.314	EAR	.375 - 16	GAP	0.880	***	26-5118
2600	1.500 Round	4.500	0.376	EAR	.375 - 16	GAP	0.880	***	26-5119
2600	1.750 Round	4.070	0.376	EAR	3/8-16 UNC (2)	EAR/GAP	0.750	***	26-5131
2600	2.000 Round	4.500	0.500	GAP	3/8-16	EAR/GAP	0.750	***	26-5202
N44 Series		B-1.31 C-2.79							
N44	1.250 Round	4.120	0.251, 0.313	EAR	3/8-16	GAP	0.880	***	44-2045
N44	1.375 Round	4.120	0.251, 0.313	EAR	3/8-16	GAP	0.880	***	44-2256
N44	1.500 Round	4.120	0.251, 0.313	EAR	3/8-16	GAP	0.880	***	44-2456
N44	1.625 Round	4.120	0.376	EAR	3/8-16	GAP	0.880	***	44-2610
N44	1.750 Round	4.120	0.376	EAR	3/8-16	GAP	0.880	***	44-2820
N44	2.000 Round	4.120	0.500	EAR	3/8-16	GAP	0.880	***	44-3200
N55 Series		A-4.44 B-1.53							
N55	1.500 Round	4.630	0.376	EAR	3/8-16	GAP	1.000	***	55-2410
N55	1.625 Round	4.500	0.376	EAR	3/8-16	GAP	1.000	***	55-2600
N55	1.750 Round	4.060	0.376	EAR	3/8-16	GAP	0.750	***	55-2800
N55	2.000 Round	4.630	0.500	EAR	1/2-13	EAR	1.130	***	55-3240
N55	2.240 Round	4.630	***	***	***	***	***	***	55-3640

PTO ROUND BORE - OUTSIDE LOCK-UP

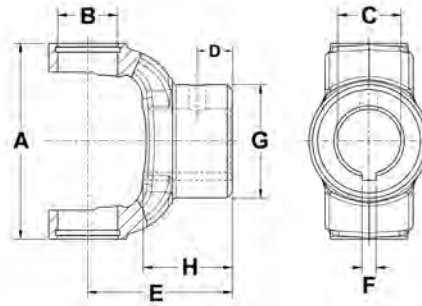

DL Series	C Bore Dia./Shape	Bolt Hole Dia.	D Bolt Hole Distance To End Of Hub	E CL To End Of Hub	F Keyway Width	Keyway Location	Set Screw Hole Size	Set Screw Location	End Of Hub To Set Screw	G Hub Dia.	Joint Angle (degrees)	H Length Through Bore	Part Number
1310 Series A-3.469 B-1.063													
1310	1.375 Round	***	***	2.562	0.312	EAR	3/8-16	GAP	0.625	2.000	17.0	1.625	N2-4-1103
1310	1.500 Round	***	***	2.562	0.375	EAR	3/8-16	GAP	***	2.125	17.0	1.625	N2-4-1233
1310	0.750 Round	***	***	2.562	***	***	***	***	***	2.000	17.0	1.625	N2-4-177
1310	1.000 Round	***	***	2.562	0.250	EAR	3/8-16	GAP	0.625	2.000	17.0	1.625	N2-4-473
1310	1.125 Round	***	***	2.562	0.250	EAR	3/8-16	GAP	0.625	2.000	17.0	1.625	N2-4-503
1310	1.250 Round	***	***	2.562	0.312	EAR	3/8-16	EAR	0.625	2.000	17.0	1.625	N2-4-533
1310	1.250 Round	***	***	2.562	***	***	***	***	***	2.000	17.0	1.625	N2-4-533-1
1310	1.250 Round	***	***	2.562	0.250	EAR	3/8-16	EAR	0.625	2.000	17.0	1.625	N2-4-573
1310	0.875 Round	***	***	2.562	0.250	EAR	3/8-16	GAP	0.625	2.000	17.0	1.625	N2-4-583
1310	1.375 Round	***	***	2.562	0.375	EAR	3/8-16	GAP	0.625	2.000	17.0	1.625	N2-4-803
1310	1.375 Round	***	***	2.562	***	***	***	***	***	2.000	17.0	1.625	N2-4-803-1
B&P1 Series A-2.126 B-0.866													
B&P1	1.250 Round	0.375	0.590	3.109	***	***	***	***	***	***	***	***	8-0517
B&P1	1.000 Round	***	***	3.281	0.250	***	3/8-16	***	***	***	***	***	8-1008
B&P1	1.250 Round	***	***	3.281	0.250	***	3/8-16	***	***	***	***	***	8-1010
B&P3 Series A-2.756 B-1.063													
B&P3	0.984 Round	0.315	0.790	3.344	***	***	***	GAP	***	***	***	***	8-0524
B&P4 Series A-2.937 B-1.063													
B&P4	1.375 Round	***	***	3.859	***	***	0.500	***	***	***	***	***	8-4016
B&P5 Series A-3.15 B-1.189													
B&P5	1.500 Round	***	***	3.781	0.375	***	3/8-16	***	0.781	***	***	***	8-0501
B&P5	1.250 Round	***	***	3.781	0.250	***	3/8-16	***	***	***	***	***	8-5010
B&P5	1.375 Round	***	***	3.781	0.312	***	3/8-16	***	***	***	***	***	8-5011
B&P5	1.375 Round	***	***	3.781	***	***	0.500	***	***	***	***	***	8-5016
B&P6 Series A-3.622 B-1.189													
B&P6	1.250 Round	***	***	4.141	0.250	***	3/8-16	***	***	***	***	***	8-6010
B&P6	1.375 Round	***	***	4.141	0.312	***	3/8-16	***	***	***	***	***	8-6011
B&P6	1.375 Round	***	***	4.344	***	***	0.500	***	***	***	***	***	8-6016

END YOKE

END YOKE

PTO ROUND BORE - OUTSIDE LOCK-UP(Cont'd)

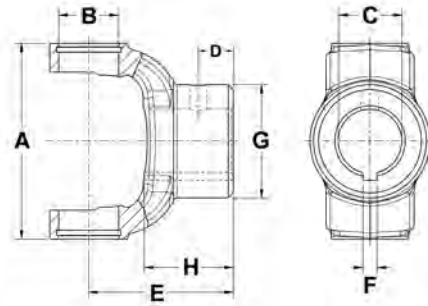

DL Series	C Bore Dia./Shape	Bolt Hole Dia.	D Bolt Hole Distance To End Of Hub	E CL To End Of Hub	F Keyway Width	Keyway Location	Set Screw Hole Size	Set Screw Location	End Of Hub To Set Screw	G Hub Dia.	Joint Angle (degrees)	H Length Through Bore	Part Number
B&P7 Series				A-3.701		B-1.378							
B&P7	1.375 Round	***	***	4.125	0.312	***	3/8-16	***	***	***	***	***	8-7011
B&P8 Series				A-4.193		B-1.378							
B&P8	1.375 Round	***	***	4.709	0.312	***	3/8-16	***	***	***	***	***	8-8011
B&P8	1.500 Round	***	***	4.709	0.312	***	3/8-16	***	***	***	***	***	8-8015
B&P8	1.750 Round	***	***	4.709	0.375	***	3/8-16	***	***	***	***	***	8-8016
W2100 Series				A-2.156		B-0.859							
W2100	25.000 Round	***	***	3.109	8.000	***	M10	***	0.594	***	***	***	8-0518
W2100	1.000 Round	***	***	3.094	***	***	0.312	***	***	***	***	***	8-2108
W2100	1.250 Round	***	***	3.094	***	***	0.375	***	***	***	***	***	8-2110
W2200 Series				A-2.413		B-0.937							
W2200	1.125 Round	***	***	3.234	0.250	***	3/8-16	***	0.781	***	***	***	8-0508
W2200	30.000 Round	***	***	3.234	8.000	***	M10	***	0.781	***	***	***	8-0510
W2200	1.500 Round	***	***	4.125	0.375	***	3/8-16	***	0.781	***	***	***	8-0514
W2200	1.750 Round	***	***	4.125	0.375	***	3/8-16	***	0.781	***	***	***	8-0515
W2200	1.250 Round	0.375	0.590	3.234	***	***	***	***	***	***	***	***	8-0521
W2200	1.375 Round	0.375	0.590	3.234	***	***	***	***	***	***	***	***	8-0522
W2200	1.250 Round	0.375	0.790	4.125	***	***	***	***	***	***	***	***	8-0528
W2200	1.000 Round	***	***	3.234	0.250	***	3/8-16	***	***	***	***	***	8-2008
W2200	1.250 Round	***	***	3.234	0.250	***	3/8-16	***	***	***	***	***	8-2010
W2300 Series				A-2.937		B-1.063							
W2300	1.500 Round	***	***	3.859	0.375	***	3/8-16	***	0.781	***	***	***	8-0512
W2300	30.000 Round	***	***	3.859	8.000	***	M10	***	0.781	***	***	***	8-0513
W2300	1.250 Round	0.375	0.790	3.859	***	***	***	***	***	***	***	***	8-0526
W2300	30.000 Round	0.394	0.790	3.859	***	***	***	***	***	***	***	***	8-0527
W2300	1.250 Round	***	***	3.859	0.250	***	3/8-16	***	***	***	***	***	8-4010
W2300	1.375 Round	***	***	3.859	0.312	***	3/8-16	***	***	***	***	***	8-4011

PTO ROUND BORE - OUTSIDE LOCK-UP(Cont'd)

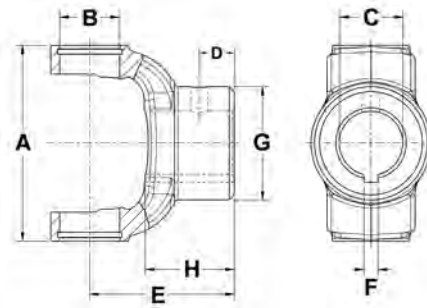

DL Series	C Bore Dia./Shape	Bolt Hole Dia.	D Bolt Hole Distance To End Of Hub	E CL To End Of Hub	F Keyway Width	Keyway Location	Set Screw Hole Size	Set Screw Location	End Of Hub To Set Screw	G Hub Dia.	Joint Angle (degrees)	H Length Through Bore	Part Number
W2400 Series A-2.992 B-1.260													
W2400	40.000 Round	***	***	3.781	12.000	***	M12	***	0.781	***	***	***	8-0505
W2400	40.000 Round	0.512	0.790	3.781	***	***	***	***	***	***	***	***	8-0520
W2400	1.250 Round	***	***	3.781	0.250	***	3/8-16	***	***	***	***	***	8-2410
W2400	1.375 Round	***	***	3.781	***	***	0.500	***	***	***	***	***	8-2411
W2500 Series A-3.504 B-1.417													
W2500	1.375 Round	***	***	4.125	0.375	***	3/8-16	***	***	***	***	***	8-2511
W2500	1.500 Round	***	***	4.125	0.375	***	3/8-16	***	***	***	***	***	8-2515
W2500	1.500 Round	0.500	***	4.125	***	***	***	***	***	***	***	***	8-2535
WI													
WI	1.250 Round	***	0.790	3.344	***	***	***	***	***	***	***	***	8-0523
WI	30.000 Round	0.394	0.790	3.344	***	***	***	***	***	***	***	***	8-0525
WI	1.250 Round	***	***	3.344	0.250	***	3/8-16	***	***	***	***	***	8-3010
WI	1.000 Round	***	***	3.344	0.250	***	3/8-16	***	***	***	***	***	8-3011
WI	1.375 Round	***	***	3.344	***	***	0.500	***	***	***	***	***	8-3016

END YOKE

PTO ROUND BORE - U-BOLT

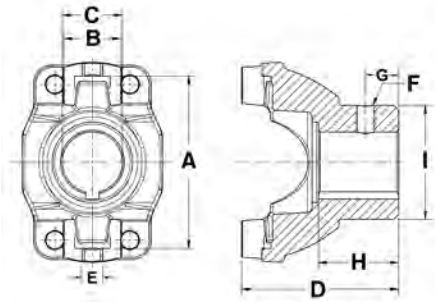

DL Series	C Bore Dia./Shape	D CL To End Of Hub	E Keyway Width	Keyway Location	F Set Screw Thread Size	Set Screw Location	G Set Screw To End Of Hub	H Length Thru Bore	I Hub Dia.	Joint Angle	Part Number
1310HR Series						A-3.219 B-1.063					
1310HR	1.125 Round	2.938	0.250	EAR	3/8-16	GAP	0.625	1.500	2.125	22.0	N2-4-782
1310HR	1.250 Round	2.938	0.312	EAR	3/8-16	GAP	0.625	1.500	2.125	22.0	N2-4-783
1310HR	1.250 Round	2.938	0.250 / 0.312	EAR	3/8-16	GAP	0.625	1.500	2.125	22.0	N2-4-783-1
1350HR Series						A-3.622 B-1.188					
1350HR	1.250 Round	3.000	0.312	EAR	3/8-16	GAP	0.625	1.500	2.250	***	N3-4-283-1

PTO ROUND BORE - WELD YOKE

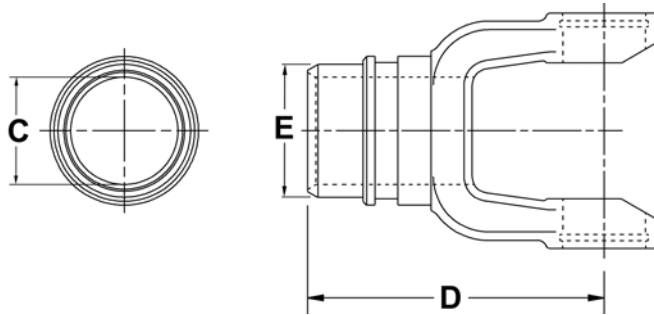

DL Series	C Bore Dia./Shape	D CL To End Of Hub	E Hub Dia.	Part Number
2200 Series		A-3.218 B-1.250 C-2.06		
2200	1.630 Round	4.440	1.975	22-1307
2200	1.630 Round	4.440	1.889	22-1325
2200	1.630 Round	4.440	2.000	22-1343
2600 Series		B-1.37 C-2.81		
2600	2.000 Round	5.250	2.540	26-5155

PTO ROUND BORE - WELD YOKE(Cont'd)

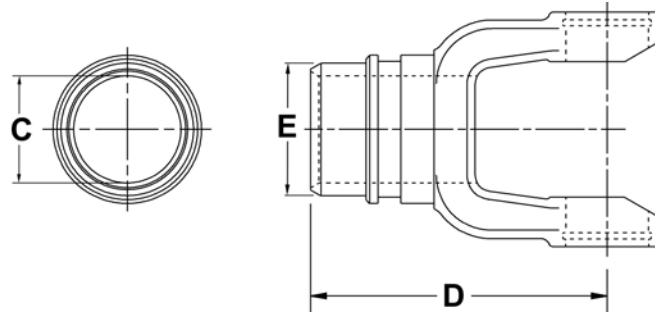

DL Series	C Bore Dia./ Shape	D CL To End Of Hub	E Hub Dia.	Part Number
N44 Series		B-1.31	C-2.79	
N44	1.870 Round	4.880	2.860	44-2200

PTO SPLINED BORE - INSIDE LOCK-UP

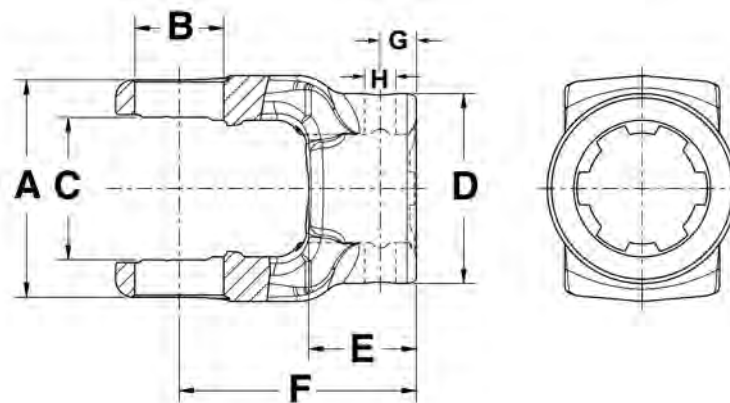

DL Series	Bore Dia./Shape	D Hub Dia.	E Length Through Bore	F CL To End Of Hub	F CL To End Of Stub	Keyway Width	Keyway Location	G End Of Hub To Set Screw	Set Screw Location	H Set Screw Thread Size	Spline/Number Teeth	Yoke Location	Part Number
1000 Series		A-2.312	B-0.938	C-1.500									
1000	1.125 6B Spline	1.625	2.031	2.500	***	***	***	0.500	GAP	0.330 DT (2)	1.125-6	***	10-0411
1000	1.375-6 Spline	2.000	1.219	2.500	***	***	***	0.375	GAP	0.330 DT (2)	1.375-6	***	10-0431
1000	1.000-15 Invo- lute Spline	***	***	5.380	5.380	***	***	***	***	***	***	***	10-0615

END YOKE

END YOKE

PTO SPLINED BORE - INSIDE LOCK-UP(Cont'd)

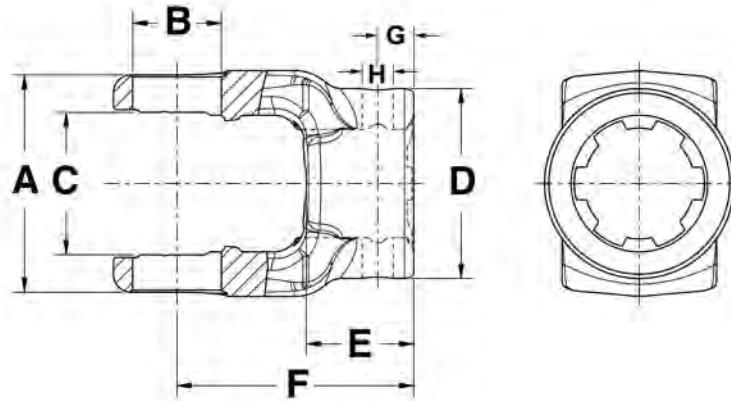

DL Series	Bore Dia./Shape	D Hub Dia.	E Length Through Bore	F CL To End Of Hub	F CL To End Of Stub	Keyway Width	Keyway Location	G End Of Hub To Set Screw	Set Screw Location	H Set Screw Thread Size	Spline/Number Teeth	Yoke Location	Part Number
1000 Series			A-2.312		B-0.938		C-1.500						
1000	1.375-6 Spline	3.562	3.030	3.500	***	***	***	***	***	***	1.375-6	Implement	10-4137
1000	1.375-6 Spline	3.562	3.030	3.500	***	***	***	***	***	***	1.375-6	Tractor	10-4139
1000	0.875-13 Invo-lute Spline	1.630	***	2.500	***	***	***	***	***	***	***	***	10-4333
1000	0.875-13 Invo-lute Spline	1.625	1.219	2.500	***	***	***	0.500	GAP	3/8-16	0.875-13	***	10-4481
1000	0.875-36 Spline	***	***	2.500	***	0.110	EAR	***	***	***	***	***	10-4841
1000	1.000 6A Spline	***	***	2.500	***	***	***	***	***	***	1.000-6	***	10-5158
1000	1.000-15 Invo-lute Spline	***	***	2.813	***	***	***	***	***	***	***	***	10-5366
1000	1.375-21 Invo-lute Spline	1.760	***	3.530	***	***	***	***	***	***	***	***	10-5411
1000	1.375-21 Spline	1.775	***	3.530	***	***	***	***	***	***	***	Implement	10-5412
1000	1.375-6B Spline	1.800	***	4.060	***	***	***	***	***	***	***	***	10-5430
1000	1.000-15 Invo-lute Spline	1.630	***	2.250	***	***	***	0.375	GAP	0.280 (Pin)	***	***	10-5871
1000	0.875-13 Invo-lute Spline	1.630	***	1.690	***	***	***	***	***	***	***	***	10-5876

END YOKE

PTO SPLINED BORE - INSIDE LOCK-UP(Cont'd)

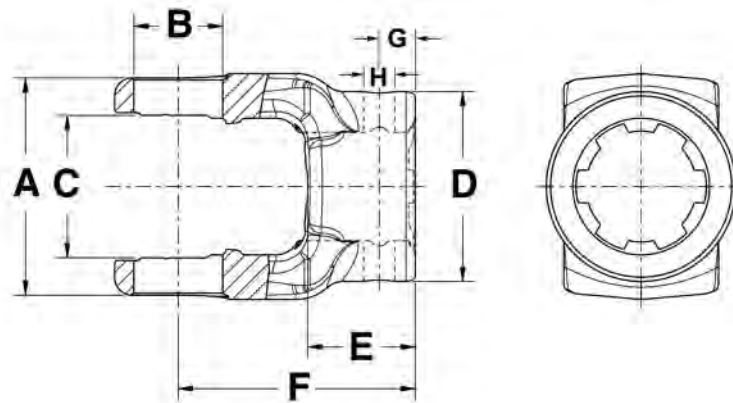

DL Series	Bore Dia./Shape	D Hub Dia.	E Length Through Bore	F CL To End Of Hub	F CL To End Of Stub	Keyway Width	Keyway Location	G End Of Hub To Set Screw	Set Screw Location	H Set Screw Thread Size	Spline/Number Teeth	Yoke Location	Part Number
				1200 Series			A-2.562	B-1.063	C-1.812				
1200	1.250-6B Spline	***	***	5.250	***	***	***	1.750	GAP	1/8-27 NPT	***	***	12-1171
1200	1.375-6B Invo-lute Spline	***	***	3.500	***	***	***	0.940	GAP	0.325 (Pin)	***	***	12-1172
1200	1.375-6B Spline	1.760	***	4.060	***	***	***	1.000	GAP	***	***	***	12-1190
1200	1.375-21 Invo-lute Spline	1.770	***	4.060	***	***	***	1.000	GAP	***	***	***	12-1193
1200	1.375-6B Spline	1.760	***	4.060	***	***	***	1.000	***	***	***	***	12-1300
1200	1.375-21 Invo-lute Spline	1.770	***	4.060	***	***	***	1.000	***	***	***	***	12-1350
1200	0.875-13 Invo-lute Spline	***	***	3.000	***	***	***	***	***	***	***	***	12-1533
1200	0.875-13 Invo-lute Spline	***	***	3.250	***	***	***	0.690	GAP	0.513 (Pin) (2)	***	***	12-1600
1200	1.000 - 15 Spline	***	***	3.250	***	***	***	0.690	***	0.523 (2)	***	***	12-1690
1200	1.000-15 Invo-lute Spline	1.500	***	3.500	***	***	***	***	GAP	0.377 (2) (QD ball hole)	***	***	12-2300
1200	1.375-6B Spline	1.800	***	4.500	***	***	***	***	***	0.502 (3) (QD ball hole)	***	***	12-2330

END YOKE

END YOKE

PTO SPLINED BORE - OUTSIDE LOCK-UP

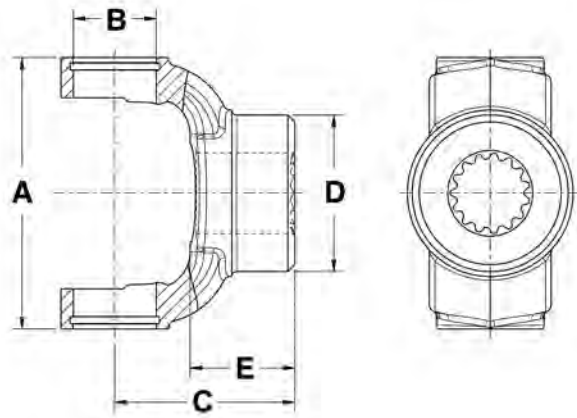

DL Series	Bore Dia./Shape	C CL To End Of Hub	D Hub Dia.	E Length Through Bore	Set Screw Hole Size	Set Screw Location	Set Screw To End Of Hub	Joint Angle	Keyway Location	Keyway Width	Spline/Number Teeth	Part Number
1310 Series						A-3.469 B-1.063						
1310	0.875-13 Invo-lute Spline	2.562	2.000	1.516	3/8-16	GAP	0.625	17.0	***	***	0.875-13	N2-4-3331
1310	1.000-15 Invo-lute Spline	2.312	2.000	1.266	***	***	***	17.0	***	***	1.000-15	N2-4-4921
1800						B-1.00 C-2.34						
1800	1.375-6B Invo-lute Spline	3.750	***	***	0.335 (Pin)	GAP	0.940	***	***	***	***	18-7132
1800	1.156-17 Invo-lute Spline	2.750	***	***	0.513 (Pin) (2)	GAP	***	***	EAR	0.13 (2)	***	18-7323
1800	1.375-6B Spline	4.450	1.800	***	***	***	***	***	***	***	***	18-7330
1800	1.375-21 Invo-lute Spline	4.350	1.800	***	0.500 (3, ball hole)	n/a	1.300	***	***	***	***	18-7339
1800	1.375-6B Spline	4.250	1.940	***	0.560 (pin hole)	GAP	0.940	***	***	***	***	18-7403
1800	1.375-6B Spline	4.250	1.940	***	0.560 (pin hole)	GAP	0.940	***	***	***	***	18-7404
1800	1 3/8 - 21 invo-lute spline	4.250	***	***	0.560	Gap	0.940	***	***	***	***	18-7405
1800	1.375-21 Invo-lute Spline	4.250	1.940	***	0.560 (pin hole)	GAP	0.940	***	***	***	***	18-7406
1800	1.250-6B Spline	3.250	2.250	***	1/2-20 UNF 2B	GAP	1.060	***	n/a	n/a	***	18-7445
1800	1.250-14 Invo-lute Spline	4.250	***	***	1/4-20 UNF 2B	GAP	0.880	***	n/a	n/a	***	18-7529

PTO SPLINED BORE - OUTSIDE LOCK-UP(Cont'd)

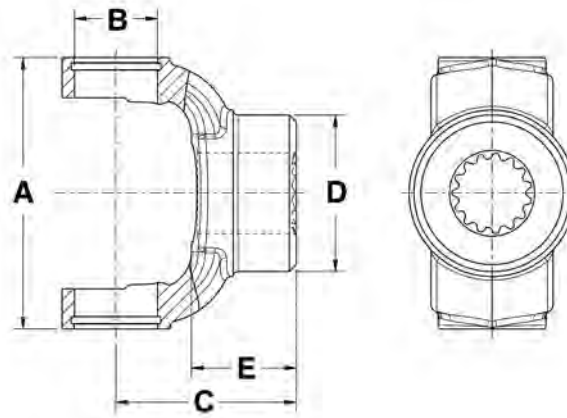

DL Series	Bore Dia./Shape	C CL To End Of Hub	D Hub Dia.	E Length Through Bore	Set Screw Hole Size	Set Screw Location	Set Screw To End Of Hub	Joint Angle	Keyway Location	Keyway Width	Spline/Number Teeth	Part Number
2000 Series A-2.625 B-1.125 C-1.85												
2000	1.375-6B Involute Spline	3.750	***	***	0.325 (Pin)	GAP	0.940	***	***	***	***	20-9132
2000	1.250-6B Spline	3.500	***	***	1/2-20	***	1.060	***	***	***	***	20-9306
2000	1.375-6B Spline	4.220	1.940	***	0.560	***	0.910	***	EAR	***	***	20-9309
2000	1.375-6B Spline	4.220	1.940	***	0.560	***	0.910	***	***	***	***	20-9319
2000	1.375-21 Involute Spline	4.750	1.805	***	0.500 (3)	***	1.290	***	***	***	***	20-9321
2000	1.375-21 Involute Spline	4.220	1.940	***	0.560	GAP	0.910	***	***	***	***	20-9324
2000	1.375-21 Involute Spline	4.220	1.940	***	0.560	GAP	0.910	***	***	***	***	20-9325
2000	1.375-6B Spline	4.750	1.805	***	0.500 (3)	***	1.290	***	***	***	***	20-9330
2200 Series A-3.218 B-1.250 C-2.06												
2200	1.375-21 Involute Spline	4.760	2.630	***	0.516	***	0.950	***	***	***	***	22-1105
2200	1.375-6B Spline	4.190	***	***	0.325	GAP	1.250	***	***	***	***	22-1134
2200	1.375-6B Spline	4.190	***	***	0.325	GAP	0.940	***	***	***	***	22-1138
2200	1.375-6B Involute Spline	4.750	***	***	0.520	GAP	0.940	***	***	***	***	22-1140
2200	1.125-6B Spline	4.190	***	***	0.325	GAP	1.250	***	***	***	***	22-1142
2200	1.375-6B Spline	4.130	2.300	***	1/2-20	Gap	1.060	***	***	***	***	22-1226
2200	1.750-20 Involute Spline	5.630	***	***	***	***	***	***	***	***	***	22-1319
2200	1.375-21 Involute Spline	4.510	***	***	0.340	Gap	1.000	***	***	***	***	22-1330
2200	1.750-20 Involute Spline	4.780	***	***	0.516	GAP	0.970	***	***	***	***	22-2275

END YOKE

END YOKE

PTO SPLINED BORE - OUTSIDE LOCK-UP(Cont'd)

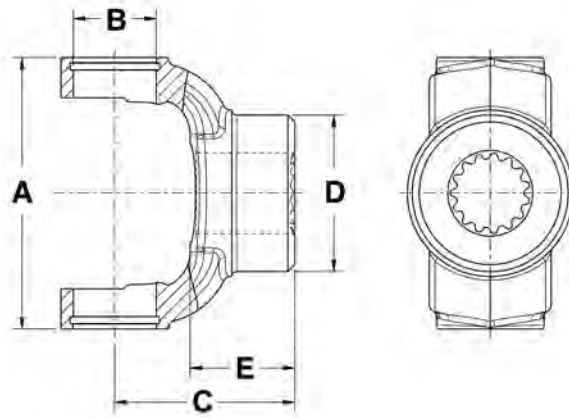

DL Series	Bore Dia./Shape	C CL To End Of Hub	D Hub Dia.	E Length Through Bore	Set Screw Hole Size	Set Screw Location	Set Screw To End Of Hub	Joint Angle	Keyway Location	Keyway Width	Spline/Number Teeth	Part Number
2200 Series A-3.218 B-1.250 C-2.06												
2200	1.375-6B Spline	4.810	2.280	***	0.560	Gap	1.000	***	***	***	***	22-2312
2200	1.375-6B Spline	4.810	2.280	***	0.560	Gap	1.000	***	***	***	***	22-2315
2200	1.375-21 Involute Spline	4.810	2.280	***	0.560	Gap	1.000	***	***	***	***	22-2316
2200	1.375-21 Involute Spline	4.810	2.280	***	0.560	Gap	1.000	***	***	***	***	22-2317
2200	1.375-6B Involute Spline	5.000	1.805	***	(3) .500	***	1.292	***	***	***	***	22-2330
2200	1.375-21 Involute Spline	5.010	1.805	***	(3) .500	***	1.292	***	***	***	***	22-3521
2600 Series B-1.37 C-2.81												
2600	1.750-27 Involute Spline	5.250	2.440	***	0.660 (Thru hole)	***	1.130	***	EAR	0.130	***	26-5135
2600	1.750-20 Spline	6.000	2.440	***	0.627 (4)	EAR/GAP	1.940	***	***	***	***	26-5163
2600	1.375-21 Involute Spline	5.070	2.260	***	0.520 (2)	GAP	1.000	***	***	***	***	26-5169
2600	1.500-23 Involute Spline	5.130	3.250	***	0.340 (thru hole)	GAP	1.000	***	***	***	***	26-5231
2600	1.375-6B Spline	5.440	1.810	***	0.502 (3)	***	1.287	***	***	***	***	26-5306
2600	1.375-21 Involute Spline	5.060	2.260	***	0.560 (2)	GAP	1.000	***	***	***	***	26-5319
2600	1.375-6B Spline	5.220	2.260	***	0.560 (2)	GAP	1.160	***	***	***	***	26-5321
2600	1.375-21 Involute Spline	5.060	2.260	***	0.560 (2)	GAP	1.000	***	***	***	***	26-5323
2600	1.375-6B Spline	5.220	2.260	***	0.560 (2)	GAP	1.160	***	***	***	***	26-5324
2600	1.375-21 Involute Spline	5.440	1.180	***	0.502 (3)	***	1.287	***	***	***	***	26-5325

END YOKE

PTO SPLINED BORE - OUTSIDE LOCK-UP(Cont'd)

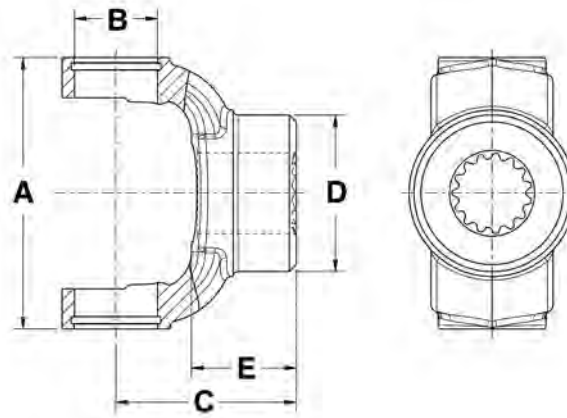

DL Series	Bore Dia./Shape	C CL To End Of Hub	D Hub Dia.	E Length Through Bore	Set Screw Hole Size	Set Screw Location	Set Screw To End Of Hub	Joint Angle	Keyway Location	Keyway Width	Spline/Number Teeth	Part Number
B&P1 Series A-2.126 B-0.866												
B&P1	1.375-6 Spline	3.625	***	***	***	***	***	***	***	***	1.375-6	8-1012
B&P1	1.375-21 Spline	3.625	***	***	***	***	***	***	***	***	1.375-21	8-1021
B&P5 Series A-3.15 B-1.189												
B&P5	1.375-6 Spline	4.406	***	***	***	***	***	***	***	***	1.375-6	8-5012
B&P6 Series A-3.622 B-1.189												
B&P6	1.750-20 Spline	4.797	***	***	***	***	***	***	***	***	1.750-20	8-0303
B&P6	1.375-21 Spline	4.406	***	***	***	***	***	***	***	***	1.375-21	8-5021
B&P6	1.375-6 Spline	4.812	***	***	***	***	***	***	***	***	1.375-6	8-6012
B&P6	1.375-21 Spline	4.812	***	***	***	***	***	***	***	***	1.375-21	8-6021
B&P7 Series A-3.701 B-1.378												
B&P7	1.375-6 Spline	4.812	***	***	***	***	***	***	***	***	1.375-6	8-7012
B&P7	1.750-20 Spline	4.812	***	***	***	***	***	***	***	***	1.750-20	8-7014
B&P7	1.375-21 Spline	4.812	***	***	***	***	***	***	***	***	1.375-21	8-7021
B&P8 Series A-4.193 B-1.378												
B&P8	1.375-6 Spline	4.921	***	***	***	***	***	***	***	***	1.375-6	8-8012
B&P8	1.750-20 Spline	4.921	***	***	***	***	***	***	***	***	1.750-20	8-8014
B&P8	1.375-21 Spline	4.921	***	***	***	***	***	***	***	***	1.375-21	8-8021
B&P9 Series A-4.252 B-1.614												
B&P9	1.375-6 Spline	4.969	***	***	***	***	***	***	***	***	1.375-6	8-0300
B&P9	1.750-20 Spline	4.969	***	***	***	***	***	***	***	***	1.750-20	8-0301
B&P9	1.375-21 Spline	4.969	***	***	***	***	***	***	***	***	1.375-21	8-0302

END YOKE

END YOKE

PTO SPLINED BORE - OUTSIDE LOCK-UP(Cont'd)

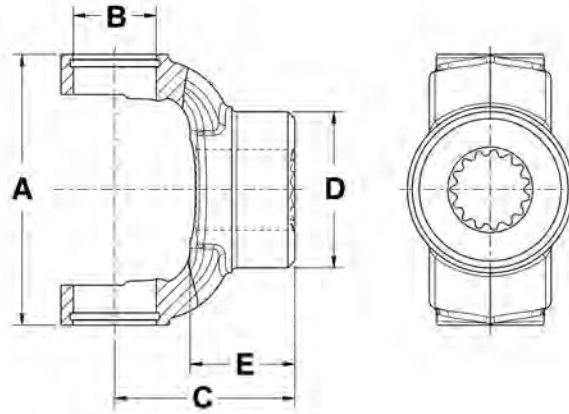

DL Series	Bore Dia./Shape	C CL To End Of Hub	D Hub Dia.	E Length Through Bore	Set Screw Hole Size	Set Screw Location	Set Screw To End Of Hub	Joint Angle	Keyway Location	Keyway Width	Spline/Number Teeth	Part Number
N44 Series B-1.31 C-2.79												
N44	1.375-21 Invo-lute Spline	4.870	***	***	0.560	GAP	1.000	***	***	***	***	44-2201
N44	1.375-6B Spline	4.120	***	***	0.325	GAP	0.880	***	***	***	***	44-2206
N44	1.375-6B Spline	4.870	***	***	0.560	GAP	1.000	***	***	***	***	44-2220
N44	1.375-6B Spline	5.290	1.180	***	0.502 (3)	***	1.294	***	***	***	***	44-4406
N44	1.375-21 Invo-lute Spline	5.290	1.180	***	0.502 (3)	***	1.294	***	***	***	***	44-4421
N44	1.750-20 Invo-lute Spline	5.000	***	***	0.638	GAP	1.000	***	***	***	***	44-4475
N44	1.750-20 Invo-lute Spline	4.880	***	***	0.692	GAP	1.000	***	***	***	***	44-6300
N55 Series A-4.44 B-1.53												
N55	1.750-20 Invo-lute Spline	5.630	***	***	0.638	GAP	1.000	***	***	***	***	55-2836
N55	1.375-6 Spline	5.310	***	***	0.560	GAP	***	***	***	***	***	55-9306
N55	1.750-20 Invo-lute Spline	6.130	***	***	0.560	GAP	***	***	***	***	***	55-9320
N55	1.375-21 Invo-lute Spline	6.130	***	***	0.560	GAP	***	***	***	***	***	55-9321
W2100 Series A-2.156 B-0.859												
W2100	1.375-6 Spline	3.625	***	***	***	***	***	***	***	***	1.375-6	8-2112
W2100	1.375-21 Spline	3.625	***	***	***	***	***	***	***	***	1.375-21	8-2121
W2200 Series A-2.413 B-0.937												
W2200	1.375-6 Spline	3.812	***	***	***	***	***	***	***	***	1.375-6	8-2012
W2200	1.375-21 Spline	3.812	***	***	***	***	***	***	***	***	1.375-21	8-2021

PTO SPLINED BORE - OUTSIDE LOCK-UP(Cont'd)

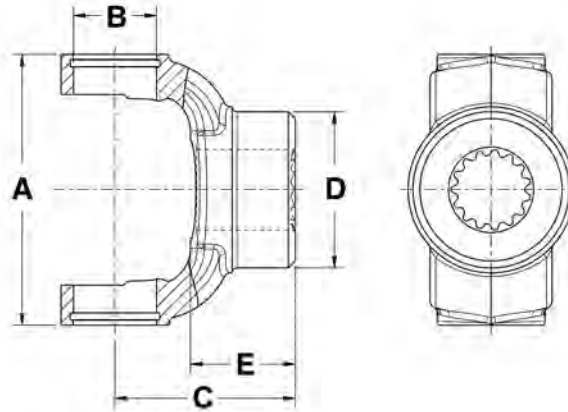

DL Series	Bore Dia./Shape	C CL To End Of Hub	D Hub Dia.	E Length Through Bore	Set Screw Hole Size	Set Screw Location	Set Screw To End Of Hub	Joint Angle	Keyway Location	Keyway Width	Spline/Number Teeth	Part Number
W2300 Series A-2.937 B-1.063												
W2300	1.375-6 Spline	4.281	***	***	***	***	***	***	***	***	1.375-6	8-4012
W2300	1.375-21 Spline	4.281	***	***	***	***	***	***	***	***	1.375-21	8-4021
W2400 Series A-2.992 B-1.260												
W2400	1.375-6 Spline	4.406	***	***	***	***	***	***	***	***	1.375-6	8-2412
W2400	1.375-21 Spline	4.406	***	***	***	***	***	***	***	***	1.375-21	8-2421
W2500 Series A-3.504 B-1.417												
W2500	1.375-6 Spline	4.812	***	***	***	***	***	***	***	***	1.375-6	8-2512
W2500	1.750-20 Spline	4.812	***	***	***	***	***	***	***	***	1.750-20	8-2514
W2500	1.375-21 Spline	4.812	***	***	***	***	***	***	***	***	1.375-21	8-2521
WI												
WI	1.375-6 Spline	4.094	***	***	***	***	***	***	***	***	1.375-6	8-3012
WI	1.375-21 Spline	4.094	***	***	***	***	***	***	***	***	1.375-21	8-3021

END YOKE

PTO - INNER TUBE PROFILE

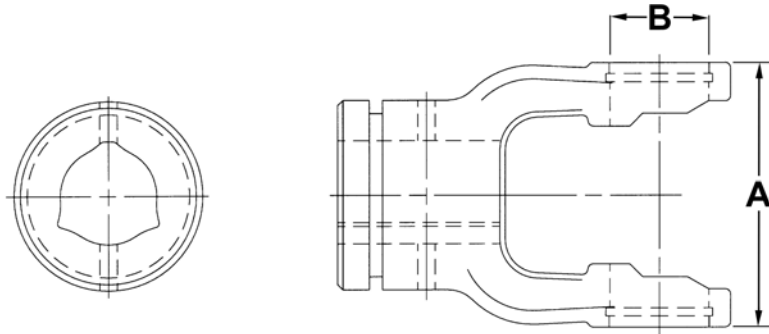

DL Series	Bore Dia./ Shape	CL To End Of Hub	Tube Pin Hole	Part Number
B&P1 Series		A-2.126	B-0.866	
B&P1	1.031 Inner Profile	3.094	***	8-1030
B&P2 Series		A-2.413	B-0.937	
B&P2	1.141 Inner Profile	3.219	***	8-2030
B&P3 Series		A-2.756	B-1.063	
B&P3	1.421 Inner Profile	3.375	***	8-3030
B&P4 Series		A-2.937	B-1.063	
B&P4	1.421 Inner Profile	3.859	***	8-4030
B&P5 Series		A-3.15	B-1.189	
B&P5	1.781 Inner Profile	3.781	***	8-5030
B&P6 Series		A-3.622	B-1.189	
B&P6	1.781 Inner Profile	4.125	***	8-6030
B&P7 Series		A-3.701	B-1.378	
B&P7	1.750 Inner Profile	4.125	***	8-7030
B&P8 Series		A-4.193	B-1.378	
B&P8	2.125 Inner Profile	4.709	***	8-8030
B&P9 Series		A-4.252	B-1.614	
B&P9	2.125 Inner Profile	5.125	0.470	8-0600
W2100 Series		A-2.156	B-0.859	
W2100	0.921 Inner Profile	3.094	***	8-2130
W2200 Series		A-2.413	B-0.937	
W2200	1.359 Inner Profile	3.234	***	8-2230
W2300 Series		A-2.937	B-1.063	
W2300	1.359 Inner Profile	3.859	***	8-2330
W2400 Series		A-2.992	B-1.260	
W2400	1.562 Inner Profile	3.781	***	8-2430
W2500 Series		A-3.504	B-1.417	
W2500	2.000 Inner Profile	4.125	***	8-2530

PTO - OUTER TUBE PROFILE

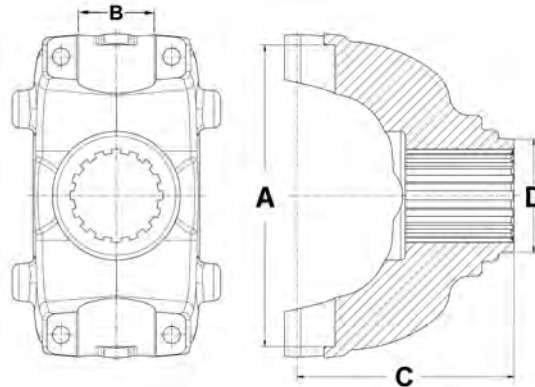

DL Series	Bore Dia./ Shape	C CL To End Of Hub	D Hub Dia.	Tube Pin Hole	Part Number
2200 Series		A-3.218	B-1.250	C-2.06	
2200	1.625 Outer Profile	3.234	2.283	***	8-2220
B&P1 Series		A-2.126	B-0.866		
B&P1	1.281 Outer Profile	3.156	***	***	8-1020
B&P2 Series		A-2.413	B-0.937		
B&P2	1.406 Outer Profile	3.312	***	***	8-2020
B&P3 Series		A-2.756	B-1.063		
B&P3	1.688 Outer Profile	3.156	***	***	8-3020
B&P4 Series		A-2.937	B-1.063		
B&P4	1.688 Outer Profile	3.688	***	***	8-4020
B&P5 Series		A-3.15	B-1.189		
B&P5	2.031 Outer Profile	3.875	***	***	8-5020
B&P6 Series		A-3.622	B-1.189		
B&P6	2.125 Outer Profile	4.219	***	***	8-6020
B&P7 Series		A-3.701	B-1.378		
B&P7	2.125 Outer Profile	4.219	***	***	8-7020
B&P8 Series		A-4.193	B-1.378		
B&P8	2.500 Outer Profile	4.709	***	***	8-8020
B&P9 Series		A-4.252	B-1.614		
B&P9	2.484 Outer Profile	5.125	***	0.470	8-0650
W2100 Series		A-2.156	B-0.859		
W2100	1.181 Outer profile	3.094	***	***	8-2120
W2300 Series		A-2.937	B-1.063		
W2300	1.625 Outer Profile	3.859	***	***	8-2320
W2400 Series		A-2.992	B-1.260		
W2400	1.891 Outer Profile	3.781	***	***	8-2420
W2500 Series		A-3.504	B-1.417		
W2500	2.406 Outer Profile	4.125	***	***	8-2520

END YOKE

END YOKE

DRIVESHAFT SPLINED - INSIDE LOCK-UP

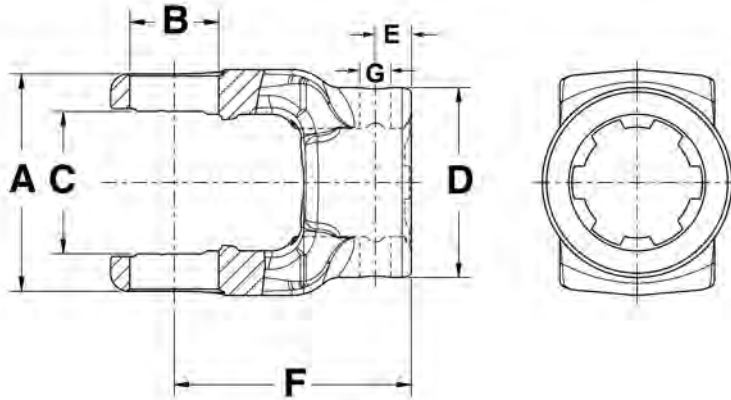

DL Series	Bore Type	Spline/Number Teeth	D Hub Dia.	E Pin Hole Distance To End Of Hub	F CL UJ To End Of Hub	G Pin Dia.	Bolt Circle	Bolt Pattern	Flange Face To CL	Hole/ Thread Size	Number Of Bolt Holes	Part Number
1000 Series							A-2.312	B-0.938	C-1.500			
1000	Splined	0.984-22	1.297	***	3.000	***	2.5	2.5 BC	2.400	M8x1.250 Thru	4	NOE-02-2125-A
1000	Splined	0.984-22	1.500	0.380-0.400	2.105	0.312-0.318 Thru	***	***	***	***	***	NOE-04-2135-A
1000	Splined	0.984-22	1.438	0.500	4.000	0.232-0.238 One side only	***	***	***	***	***	NOE-04-2141-A
1000	Splined	0.984-22	1.625	0.500	2.500	0.312-0.318 Thru	***	***	***	***	***	NOE-04-2144-A
1000	Splined	0.984-22	1.438	1.562	4.000	0.232-0.238 One side only	***	***	***	***	***	NOE-04-2179-A
1000	Splined	0.984-21 based on 22	1.438	1.562	4.000	0.232-0.238 One side only	***	***	***	***	***	NOE-04-2181-A
1000	Splined	0.984-22	1.438	0.688	3.438	0.232-0.238 One side only	***	***	***	***	***	NOE-04-2183-A
1000	Splined	0.984-22	1.438	0.688	3.656	0.232-0.238 One side only	***	***	***	***	***	NOE-04-2185-A
1000	Splined	0.984-22	1.438	0.688	3.219	0.232-0.238 One side only	***	***	***	***	***	NOE-04-2190-A
1000	Splined	0.984-22	1.438	0.500	3.297	0.232-0.238 One side only	***	***	***	***	***	NOE-04-2192-A
1000	Splined	0.984-22	1.500	***	1.938	***	***	***	***	***	***	NOE-04-2654-A
1000/0300							A-1.890	B-0.838	C-1.603			
1000/0300	Splined	0.984-22	1.375	0.375-0.406	2.109	0.314-0.318 Thru	***	***	***	***	***	NOE-04-3871-A
1000/0300	Splined	0.984-22	1.375	0.500	3.297	0.232-0.238	***	***	***	***	***	NOE-04-3872-A
1000 Series							A-2.312	B-0.938	C-1.500			
1000	Splined	1.026-15	1.625	***	2.500	***	***	***	***	***	***	NOE-04-5695-A
1000	Splined	0.984-22	1.500	1.562	4.000	0.232-0.238	***	***	***	***	***	NOE-04-6032-A

DRIVESHAFT SPLINED - OUTSIDE LOCK-UP

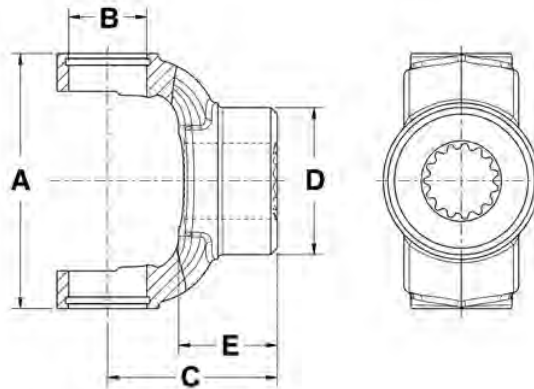

DL Series	Spline/Number Teeth	C CL To End Of Hub	D Hub Dia.	E Length Through Bore	Hole/ Thread Size	Pin Dia.	Pin Hole To End Of Hub	UJ Retention	Part Number
1310 Series					A-3.469				
					B-1.063				
1310	1.250-19 Involute Spline	2.500	1.995	1.450	1/4-28 UNF 2B	0.120	0.590	OSR	N2-4-1087
1310	30mm-22	2.560	2.005	1.510	***	***	***	OSR	N2-4-4921-22
1350 Series					A-3.875				
					B-1.188				
1350	1.375-10	3.310	1.770	1.781	***	***	***	***	N3-4-FD03

END YOKE

SPLINED - CV CONSTRUCTION

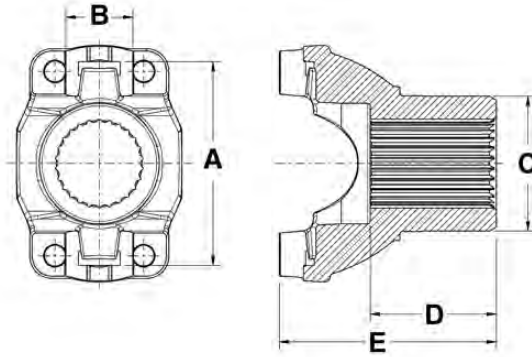

DL Series	Spline/Number Teeth	UJ Retention	C Hub Dia.	D Length Thru Hole	E CL To End Of Hub	Joint Angle	Part Number
1310HR Series				A-3.219 B-1.063			
1310HR	1.125-10	CV	1.547	1.500	3.000	13.0	N2-4-4061X
1310HR	1.146-26	CV	1.547	1.500	3.000	13.0	N2-4-4341
1310HR	1.401-32	CV	1.875	2.000	3.875	13.0	N2-4-5341
1310HR	1.401-32	CV	1.939	2.000	3.844	13.0	N2-4-JK03
1350HR Series				A-3.622 B-1.188			
1350HR	1.401-32	CV	1.939	2.000	4.010	***	N3-4-JL-TCF

SPLINED - U-BOLT CONSTRUCTION

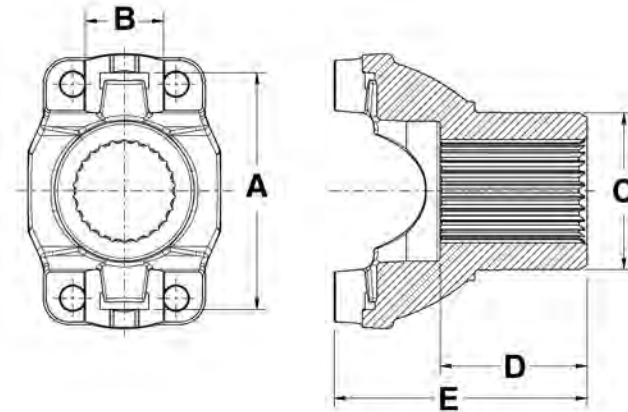

DL Series	Spline/Number Teeth	Uj Retention	C Hub Dia.	D Length Thru Hole	E CL To End Of Hub	Joint Angle	Part Number
1310HR Series				A-3.219	B-1.063		
1310HR	1.375-10	U-Bolt	1.750	1.750	3.219	20.0	N2-4-2671
1310HR	1.125-10	U-Bolt	1.547	1.500	3.000	25.0	N2-4-2791
1310HR	1.276-29	U-Bolt	1.875	1.500	2.938	18.0	N2-4-3801X
1310HR	1.401-32	U-Bolt	2.125	2.000	3.438	22.0	N2-4-4191
1310HR	1.146-26	U-Bolt	1.547	1.500	3.000	22.5	N2-4-8091X
1310HR	1.235-28	U-Bolt	1.812	2.422	4.031	25.0	N2-4-FD01X
1330HR	1.235-28	U-Bolt	1.812	2.422	4.031	25.0	N2-4-FD02X
1310HR	1.328-30	U-Bolt	1.734	1.188	2.594	25.0	N2-4-GM01X
1330HR	1.328-30	U-Bolt	1.734	1.188	2.703	25.0	N2-4-GM02X
1310HR	1.312-30	U-Bolt	1.938	1.156	3.156	20.0	N2-4-GM03X
1310HR	1.401-32	U-Bolt	1.939	2.000	3.438	22.0	N2-4-JK01
1310HR	1.250-24	U-Bolt	1.875	1.500	3.000	22.0	N2-4-JK02
1310HR	1.250-24	U-Bolt	1.846	1.500	3.000	22.0	N2-4-JK06
1310HR	1.496-28	U-Bolt	2.115	1.710	3.125	***	N2-4-JL02-1X
1310HR	1.250-24	U-Bolt	1.865	1.710	3.250	***	N2-4-JL03-1X
1310HR	1.496-28	U-Bolt	2.124	1.840	3.250	***	N2-4-JL04-1X
1310HR	1.250-24	U-Bolt	1.874	1.430	3.130	***	N2-4-JL05-1X
1350HR Series				A-3.622	B-1.188		
1350HR	1.250-24	U-Bolt	1.887	1.500	3.094	22.0	N3-4-JK04
1350HR	1.250-24	U-Bolt	1.887	1.500	3.094	22.0	N3-4-JK08
1350HR	1.496-28	U-Bolt	2.123	1.720	3.250	***	N3-4-JL02-1X
1350HR	1.250-24	U-Bolt	1.874	1.670	3.250	***	N3-4-JL03-1X
1350HR	1.496-28	U-Bolt	2.125	1.840	3.250	***	N3-4-JL04-1X
1350HR	1.250-24	U-Bolt	1.912	***	3.000	***	N3-4-JL05-1X

END YOKE

END YOKE

SPLINED - BEARING STRAP CONSTRUCTION

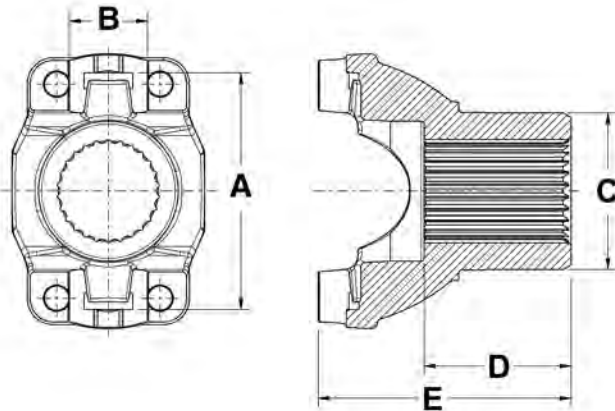

DL Series	Spline/Number Teeth	UJ Retention	C Hub Dia.	D Length Thru Hole	E CL To End Of Hub	Joint Angle	Flinger/boot Part Number	Sleeve Dia.	Part Number
1350HR Series					A-3.622	B-1.188			
1350HR	1.312-30	Strap	1.938	1.156	3.188	***	***	2.109	N3-4-0880-1X
1350HR	1.375-10	Strap	1.719	1.781	3.281	20.5	98-1473	***	N3-4-178-1X
1350HR	1.375-10	Strap	1.719	1.781	3.281	20.5	***	***	N3-4-2171-1
1410HR Series					A-4.187	B-1.188			
1410HR	1.500-10	Strap	1.812	2.000	3.719	24.0	***	***	N3-4-6561-1
1410HR	1.500-10	Strap	1.812	2.000	3.719	24.0	231004	***	N3-4-6631X
1550HR Series					A-4.965	B-1.375			
1550HR	1.500-10	Strap	2.312	2.000	3.781	22.0	***	***	N4-4-2051-1
1610HR Series					A-5.312	B-1.875			
1610HR	1.750-10	Strap	2.188	2.250	4.125	***	***	***	N5-4-1721-1X
1610HR	2.000-39	Strap	3.000	2.312	4.875	***	***	***	N5-4-6441-1X
1610HR	1.790-34	Strap	2.188	2.250	4.125	22.0	***	***	N5-4-7171-1
1710HR Series					A-6.1902	B-1.938			
1710HR	1.960-10	Strap	2.812	3.000	5.000	***	***	***	N6-4-1981-1
1710HR	2.340-16	Strap	3.312	2.750	4.938	20.0	***	***	N6-4-4601-1
1710HR	2.280-44	Strap	2.938	2.500	5.188	27.0	***	***	N6-4-6041-1X
1710HR	2.000-39	Strap	3.000	2.312	6.250	***	***	***	N6-4-6371-1
1710HR	2.000-39	Strap	3.000	2.312	6.250	***	231359	***	N6-4-6391-1X
1710HR	2.500-10	Strap	3.750	3.000	5.625	30.0	***	***	N6-4-6921-1X
1710HR	2.750-10	Strap	3.750	3.000	5.750	20.0	***	***	N6-4-6931-1X
1710HR	2.000-38	Strap	2.812	3.000	5.000	25.0	***	***	N6-4-7141-1
1710HR	2.380-46	Strap	3.250	2.328	5.375	***	***	***	N6-4-7181-1X
1710HR	2.390-46	Strap	2.875	2.750	4.938	20.5	***	***	N6-4-7481-1
1710HR	2.000-39	Strap	3.000	2.312	5.156	28.0	DEFR59-2	***	N6-4-7631-1X
1710HR	2.000-39	Strap	3.000	2.312	5.156	28.0	DEFR59-1	***	N6-4-7641-1X
1710HR	2.020-39	Strap	2.750	2.000	5.000	33.5	***	***	N6-4-8331-1X

SPLINED - BEARING STRAP CONSTRUCTION (Cont'd)

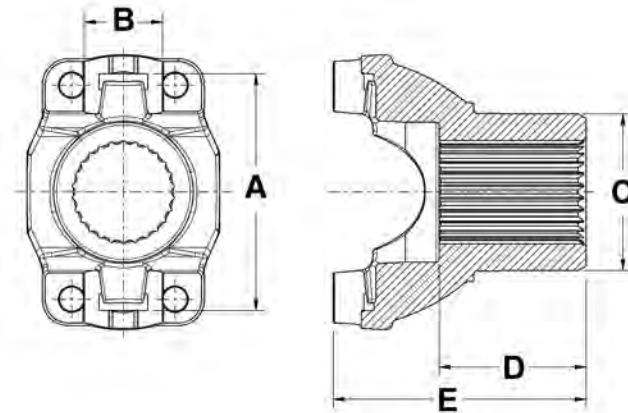

DL Series	Spline/Number Teeth	UJ Retention	C Hub Dia.	D Length Thru Hole	E CL To End Of Hub	Joint Angle	Finger/boot Part Number	Sleeve Dia.	Part Number
1710HR Series					A-6.1902	B-1.938			
1710HR	2.020-39	Strap	3.000	2.281	6.125	39.5	***	***	N6-4-8991-1X
1710HR	2.020-39	Strap	2.625	2.500	6.125	39.5	***	***	N6-4-9001-1X
1760HR Series					A-7.094	B-1.938			
1760HR	2.390-46	Strap	3.250	2.328	5.062	***	***	***	N6.3-4-1041-1X
1760HR	2.390-46	Strap	3.500	2.406	5.375	30.0	***	***	N6.3-4-1391-1X
1760HR	2.110-32	Strap	3.000	2.250	5.000	30.5	***	***	N6.3-4-1521-1X
1760HR	2.340-16	Strap	2.875	2.750	5.500	30.0	***	***	N6.3-4-161-1
1760HR	2.790-54	Strap	***	2.750	5.625	***	***	***	N6.3-4-1681-1
1760HR	2.280-44	Strap	2.938	2.500	5.250	26.0	***	***	N6.3-4-331-1X
1760HR	2.270-44	Strap	3.000	2.500	5.250	30.0	***	***	N6.3-4-5221-1X
1760HR	2.000-39	Strap	3.000	2.312	5.188	30.0	***	***	N6.3-4-541-1X
1760HR	2.500-10	Strap	3.750	3.000	6.031	32.0	***	***	N6.3-4-781-1X
1760HR	2.750-10	Strap	3.750	3.000	5.969	30.0	***	***	N6.3-4-791-1X
1760HR	2.380-46	Strap	3.312	2.750	5.500	30.0	***	***	N6.3-4-821-1
1810HR Series					A-7.643	B-1.938			
1810HR	2.340-16	Strap	3.312	2.750	5.500	30.0	***	***	N6.5-4-1891-1
1810HR	2.270-44	Strap	2.938	2.500	5.250	30.0	***	***	N6.5-4-3281-1X
1810HR	2.000-39	Strap	3.000	2.312	5.188	30.0	***	***	N6.5-4-3381-1X
1810HR	2.500-10	Strap	3.750	3.000	5.875	30.0	***	***	N6.5-4-3551-1X
1810HR	2.750-10	Strap	3.750	3.000	6.062	30.0	***	***	N6.5-4-3561-1X
1810HR	2.380-46	Strap	3.312	2.750	5.500	30.0	***	***	N6.5-4-3591-1
1810HR	2.380-46	Strap	3.250	2.328	5.156	***	***	***	N6.5-4-3721-1
1810HR	2.380-46	Strap	3.250	2.328	5.156	***	231803	***	N6.5-4-3731-1X
1810HR	2.380-46	Strap	3.375	3.188	6.000	30.0	***	***	N6.5-4-3921-1X
1810HR	2.270-44	Strap	3.000	2.500	5.250	30.0	***	***	N6.5-4-4571-1X
1810HR	2.790-54	Strap	***	2.750	5.625	30.0	***	***	N6.5-4-4631-1

END YOKE

END YOKE

SPLINED - BEARING STRAP CONSTRUCTION (Cont'd)

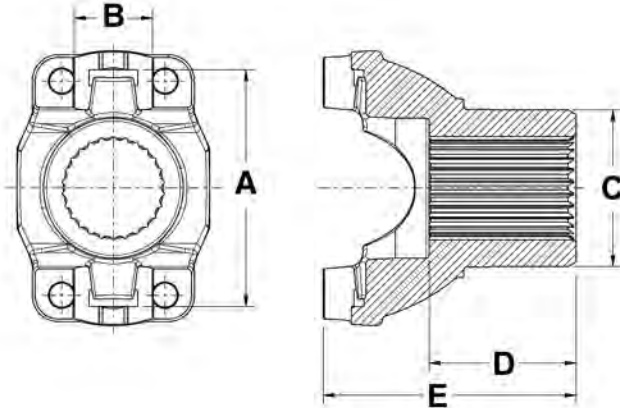

DL Series	Spline/Number Teeth	UJ Retention	C Hub Dia.	D Length Thru Hole	E CL To End Of Hub	Joint Angle	Flinger/boot Part Number	Sleeve Dia.	Part Number
3R Series			A-3.563 B-1.125 C-2.563						
3R*	1.312-30	Strap	1.938	1.156	3.125	***	***	2.109	N3R-4-0876-1X
3R*	1.209-27	Strap	1.516	1.484	3.344	***	***	1.688	N3R-4-5850-1X
3R*	1.312-30	Strap	1.938	1.156	3.125	***	***	***	N3R-4-8336-1X
SPL170HR Series			A-6.457 B-2.165						
SPL170HR*	2.390-46	Strap	***	2.750	5.594	25.0	***	***	N170-4-1271-1
SPL170HR*	2.270-44	Strap	3.000	2.500	5.266	25.0	***	***	N170-4-201-1X
SPL170HR*	2.020-39	Strap	2.625	2.500	6.500	45.0	***	***	N170-4-241-1X
SPL170HR*	2.020-39	Strap	3.000	2.281	5.156	25.0	***	***	N170-4-261-1X
SPL170HR*	2.020-39	Strap	3.000	2.281	6.250	45.0	***	***	N170-4-281-1X
SPL170HR*	2.750-10	Strap	3.750	3.000	5.859	25.0	***	***	N170-4-521-1X
SPL170HR*	2.790-54	Strap	***	2.750	5.603	25.0	***	***	N170-4-561-1
SPL170HR*	2.020-39	Strap	3.000	2.312	6.391	45.0	***	***	N170-4-671-1X
SPL170HR*	2.390-46	Strap	3.250	2.328	5.094	25.0	***	***	N170-4-721-1X
SPL250HR Series			A-6.413 B-2.361						
SPL250HR*	2.390-46	Strap	***	2.750	5.750	25.0	***	***	N250-4-21-1
SPL250HR*	2.750-10	Strap	3.750	3.000	6.297	25.0	***	***	N250-4-241-1X
SPL250HR*	2.790-54	Strap	***	2.750	5.703	25.0	***	***	N250-4-271-1
SPL250HR*	2.390-46	Strap	3.250	2.312	5.312	25.0	***	***	N250-4-351-1X
SPL250HR*	2.270-44	Strap	3.000	2.500	5.500	25.0	***	***	N250-4-81-1X

* SPL - Spicer® Life Series driveshafts is a registered trademark of Dana Limited

SPLINED - BEARING PLATE CONSTRUCTION

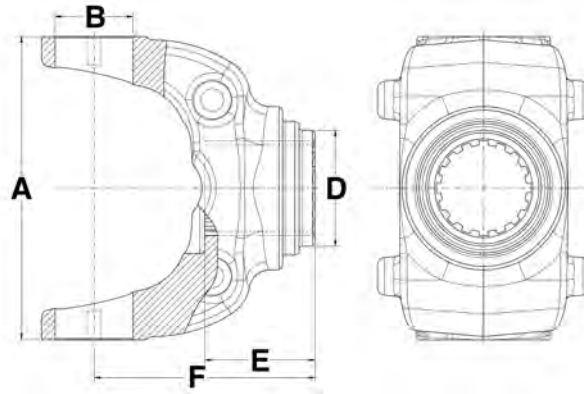

DL Series	Spline/Number Teeth	UJ Retention	D Hub Dia.	E Length Thru Hole	F CL To End Of Hub	Joint Angle	Flinger/boot Part Number	Part Number
1610 Series				A-5.312 B-1.875				
1610	1.750-10	Plate	2.188	2.250	4.125	24.0	***	N5-4-1721
1610	2.000-39	Plate	3.000	2.312	6.219	45.0	***	N5-4-6291X
1710 Series				A-6.094 B-1.938				
1710	1.960-10	Plate	2.812	3.000	5.000	21/32	***	N6-4-1981
1710	2.250-10	Plate	3.500	3.000	5.250	22.0	***	N6-4-2141
1710	2.340-16	Plate	2.875	2.750	4.938	26.0	***	N6-4-4601
1710	2.340-16	Plate	2.875	2.750	4.938	26.0	230746	N6-4-5071X
1710	2.020-39	Plate	2.625	2.250	5.250	33.5	***	N6-4-6001X
1710	2.024-39	Plate	2.625	2.250	6.125	45.0	***	N6-4-6021X
1710	2.274-44	Plate	2.938	2.500	5.188	27.0	***	N6-4-6041X
1710	1.750-34	Plate	2.500	2.250	4.875	30.0	***	N6-4-6331
1710	2.024-39	Plate	3.000	2.312	6.250	45.0	***	N6-4-6371
1710	2.024-39	Plate	3.000	2.312	6.250	45.0	231359	N6-4-6391X
1710	2.024-39	Plate	3.000	2.312	5.156	28.0	***	N6-4-6401
1710	2.024-39	Plate	3.000	2.312	5.156	28.0	DEFR59-2	N6-4-6411X
1710	2.024-39	Plate	3.000	2.312	5.156	28.0	DEFR59-1	N6-4-6421X
1710	1.780-34	Plate	2.625	2.438	6.312	45.0	***	N6-4-6451
1710	1.780-34	Plate	2.625	2.438	5.438	33.5	***	N6-4-6481
1710	2.500-10	Plate	2.938/3.750	3.000	5.625	30.0	***	N6-4-6921
1710	2.750-10	Plate	3.750	3.000	5.750	22.0	***	N6-4-6931X
1710	2.024-39	Plate	2.750	2.438	5.250	30.0	***	N6-4-6951X
1710	2.380-46	Plate	3.250	2.328	5.375	31.0	***	N6-4-7181X
1710	2.143-41	Plate	2.938	3.000	6.625	***	***	N6-4-7541
1710	2.143-41	Plate	2.938	2.500	6.125	42.5	***	N6-4-7561X
1710	2.380-46	Plate	3.250	2.328	6.500	31.0	***	N6-4-7771X
1710	1.790-34	Plate	2.625	2.438	5.438	34.0	***	N6-4-8511X

END YOKE

END YOKE

SPLINED - BEARING PLATE CONSTRUCTION (Cont'd)

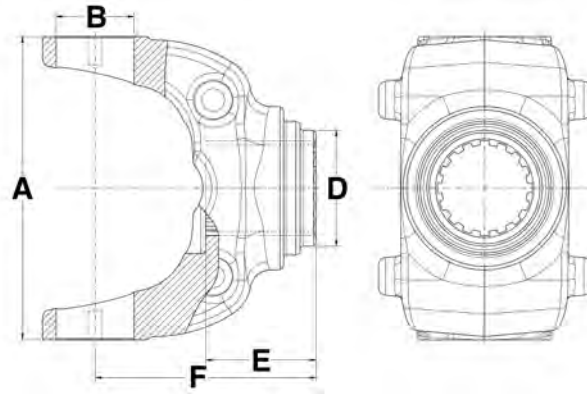

DL Series	Spline/Number Teeth	UJ Retention	D Hub Dia.	E Length Thru Hole	F CL To End Of Hub	Joint Angle	Flinger/boot Part Number	Part Number
1710 Series A-6.094 B-1.938								
1710	1.790-34	Plate	2.625	2.438	6.312	45.0	***	N6-4-8521X
1710	2.024-39	Plate	2.625	2.250	5.250	***	***	N6-4-8531X
1760 Series A-7.000 B-1.938								
1760	2.390-46	Plate	3.250	2.328	5.062	29.0	***	N6.3-4-1041X
1760	2.340-16	Plate	2.859	2.750	5.500	30.0	***	N6.3-4-161
1760	2.280-44	Plate	3.000	2.500	5.250	***	***	N6.3-4-5221X
1760	2.000-39	Plate	3.000	2.312	5.188	29.0	***	N6.3-4-541X
1760	2.750-10	Plate	3.750	3.000	5.969	30.0	***	N6.3-4-791X
1810 Series A-7.547 B-1.938								
1810	2.340-16	Plate	2.875	2.750	5.500	30.0	***	N6.5-4-1891
1810	2.750-10	Plate	3.375	2.938	6.000	30.0	***	N6.5-4-2171
1810	2.220-6	Plate	3.000	3.250	6.000	30.0	***	N6.5-4-2271X
1810	2.340-16	Plate	2.875	2.750	5.500	30.0	230746	N6.5-4-2531X
1810	2.380-46	Plate	3.250	2.625	5.438	30.0	***	N6.5-4-2711X
1810	2.280-44	Plate	2.938	2.500	5.250	30.0	***	N6.5-4-3281X
1810	2.750-10	Plate	3.750	3.000	6.062	30.0	***	N6.5-4-3561X
1810	2.380-46	Plate	3.312	2.750	5.500	***	***	N6.5-4-3591
1810	2.380-46	Plate	3.250	2.328	5.156	***	***	N6.5-4-3731X
1810	2.790-54	Plate	***	2.750	5.625	30.0	***	N6.5-4-4631

SPLINED - WING RPL CONSTRUCTION

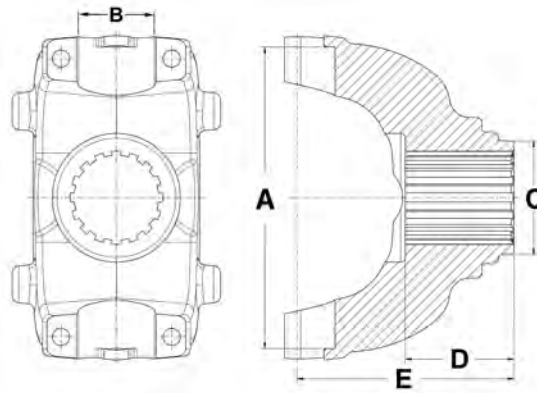

DL Series	Spline/Number Teeth	UJ Retention	C Hub Dia.	D Length Thru Hole	E CL To End Of Hub	Flinger/boot Part Number	Part Number
20R Series				A-7.06			
20R	2.000-39	Wing-RPL	3.000	2.312	4.843	***	N20WYS32-17
20R	2.000-39	Wing-RPL	3.000	2.312	5.953	***	N20WYS32-2
20R	2.000-39	Wing-RPL	3.000	2.312	5.953	DEFR64	N20WYS32-2A
20R	2.380-46	Wing-RPL	3.250	2.328	4.906	***	N20WYS38-4A
20R	2.750-10	Wing-RPL	3.750	3.000	5.094	***	N20WYS44-2A
20R	2.790-54	Wing-RPL	3.750	2.750	5.250	***	N20WYS45
20R	2.380-46	Wing-RPL	2.875	2.750	4.906	***	N20WYSC38-18
25R Series				A-8.375 B-2.062			
25R	2.380-46	Wing-RPL	3.250	2.328	4.734	DEFR64-3	N25WYS38-13A
25R	2.380-46	Wing-RPL	3.250	2.328	4.734	DEFR64-10	N25WYS38-13A4
25R	2.750-10	Wing-RPL	3.750	3.000	5.094	***	N25WYS44-2A
25R	2.790-54	Wing-RPL	3.750	2.750	5.875	***	N25WYS45
25R	2.380-46	Wing-RPL	2.875	2.750	4.906	***	N25WYSC38-11

END YOKE

SPLINED - STEERING CLAMP CONSTRUCTION

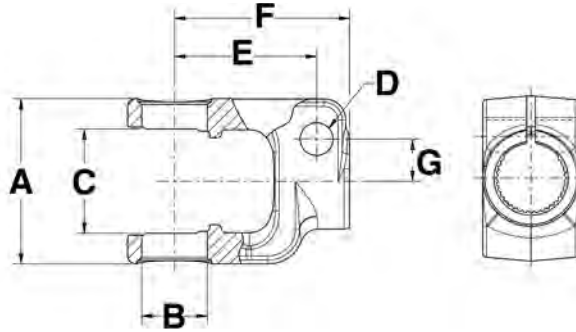

DL Series	Spine/Number Teeth	D Bolt Hole Dia.	E CL Of Brg Cap To CL Of Bolt Hole	F CL To End Of Hub	G CL Of Spine To CL Of Bolt Hole	Part Number
1000 Series						
			A-2.312 B-0.938 C-1.500			
1000	1.011-26/36	0.410	2.031	2.500	0.609	10-4731
1000	1.011-26/36	0.470	2.031	2.500	0.594	10-4961

SPLINED, WING BEARING CONSTRUCT

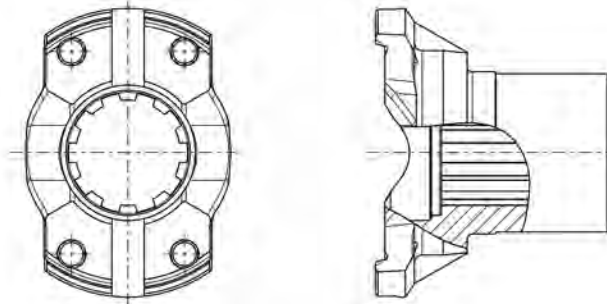

DL Series	Bore Type	Spine/Number Teeth	Hole/ Thread Size	D Hub Dia.	E Length Thru Bore	F Face To End	Part Number
7C							
7C	Splined	1.750-10	0.470	2.375	2.188	3.438	10508J

Notes



THE DRIVELINE EXPERTS

Center and Tube Weld Yoke

SECTION

5

SUB SECTION

C.V. Ball Stud Tube Weld Yoke -
Inside Lock-up

C.V. Ball Stud Tube Weld Yoke -
Outside Lock-up

C.V. Ball Stud Tube Weld Yoke -
Extended Lube

C.V. Centering Yoke

C.V.H Yoke - Inside Lock-up

AND MUCH MORE!

**Manufacturing Driveline Solutions®
in the USA Since 1921.**

NeapcoAftermarket.com



CENTER & TUBE WELD YOKE

C.V. BALL STUD TUBE WELD YOKE - INSIDE LOCK-UP

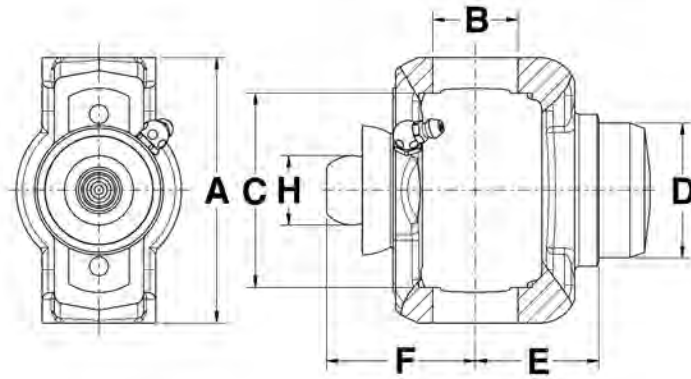

DL Series	Tubing Dia. and Wall	D Butt Dia.	E CL To Point of Weld	F CL To End Of Ball Stud	H Ball Stud Dia.	Joint Angle (Max)	Part Number
3R Series			A-3.563	B-1.125	C-2.563		
3R	2.750 x .065	2.844	1.625	1.984	0.906	8.5	N3R-28-341
3R	2.000 x 0.120	1.766	1.625	1.984	0.906	8.5	N3R-28-869

C.V. BALL STUD TUBE WELD YOKE - OUTSIDE LOCK-UP

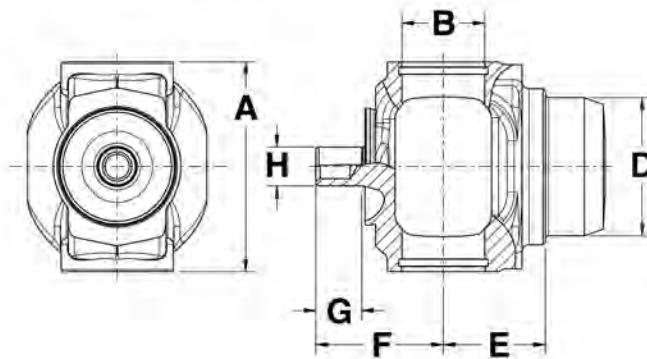

DL Series	Tubing Dia. and Wall	D Butt Dia.	E CL To Point of Weld	F CL To End Of Ball Stud	G Ball Stud Length	H Ball Stud Dia.	Joint Angle (Max)	Part Number
1330 Series			A-3.875	B-1.063				
1330	3.000 x .065	2.875	1.500	1.656	0.594	0.500	13.0	N2-28-2117X
1330	2.500 x .083	2.344	1.375	1.656	0.594	0.500	13.0	N2-28-2137X
1330	2.000 x 0.120	1.766	1.375	1.656	0.594	0.500	13.0	N2-28-2157X
1210 Series			A-2.56	B-1.063				
1210	2.000 x 0.120	n/a	n/a	1.580	0.600	0.500	***	N2-28-2467X

CENTER & TUBE WELD YOKE

C.V. BALL STUD TUBE WELD YOKE - OUTSIDE LOCK-UP (Cont'd)

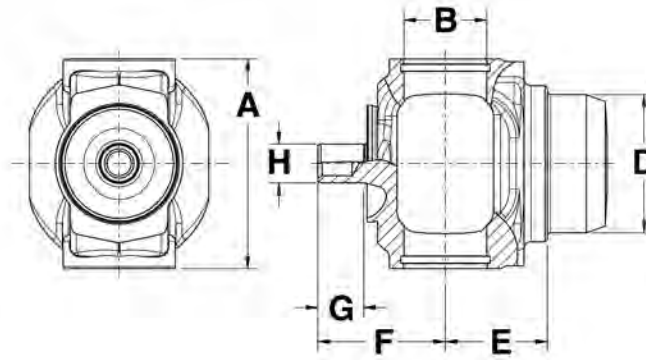

DL Series	Tubing Dia. and Wall	D Butt Dia.	E CL To Point of Weld	F CL To End Of Ball Stud	G Ball Stud Length	H Ball Stud Dia.	Joint Angle (Max)	Part Number
1310 Series A-3.469 B-1.063								
1310	1.750 x .095	1.562	1.438	1.641	0.594	0.500	13.0	N2-28-2937X
1310	2.000 x 0.120	1.766	1.438	1.641	0.594	0.500	13.0	N2-28-2947X
1310	2.500 x .083	2.344	1.438	1.641	0.594	0.500	13.0	N2-28-2957X
1310	3.000 x .065	2.875	1.438	1.641	0.594	0.500	13.0	N2-28-2967X
1310	3.000 x .083	2.844	1.438	1.641	0.594	0.500	13.0	N2-28-2977X
1310	2.750 x .065	2.625	1.438	1.641	0.594	0.500	13.0	N2-28-2987X
1310	1.250 x 0.120	1.016	1.438	1.641	0.594	0.500	13.0	N2-28-2997X
1310	2.750 x .083	2.594	1.438	1.641	0.594	0.500	13.0	N2-28-3817X
1410 Series A-4.438 B-1.188								
1410	2.500 x 0.120	2.258	2.100	***	***	***	***	N3-28-1410X
1410	***	2.594	***	***	***	***	***	N3-28-1411X

CENTER & TUBE WELD YOKE

C.V. BALL STUD TUBE WELD YOKE - EXTENDED LUBE

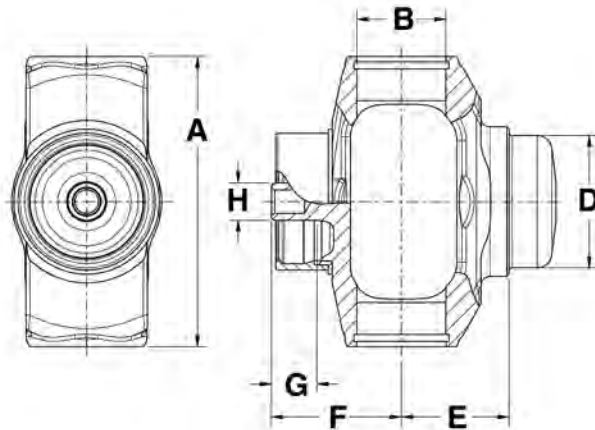

DL Series	Tubing Dia. and Wall	D Butt Dia.	E CL To Point of Weld	F CL To End Of Ball Stud	G Ball Stud Length	H Ball Stud Dia.	Joint Angle (Max)	Flinger/boot Part Number	Part Number
1210 Series					A-2.56 B-1.063				
1210	***	0.875	***	1.630	0.630	0.500	***	N230933	N2-28-1290X
1310 Series					A-3.469 B-1.063				
1310	2.750 x .065	2.625	1.438	1.641	0.594	0.500	13.0	N2-86-418	N2-28-2747X
1310	1.750 x .095	1.562	1.438	1.641	0.594	0.500	13.0	N2-86-418	N2-28-2827X
1310	2.000 x 0.120	1.766	1.438	1.641	0.594	0.500	13.0	N2-86-418	N2-28-2867X
1310	2.500 x .083	2.344	1.438	1.641	0.594	0.500	13.0	N2-86-418	N2-28-2887X
1310	3.000 x .065	2.875	1.438	1.641	0.594	0.500	13.0	N2-86-418	N2-28-2907X
1310	3.000 x .083	2.844	1.438	1.641	0.594	0.500	13.0	N2-86-418	N2-28-2927X
1330 Series					A-3.875 B-1.063				
1330	2.500 x .083	2.344	1.375	1.656	0.594	0.500	9.0	N2-86-418	N2-28-3067X
1310 Series					A-3.469 B-1.063				
1310	2.500 x .065	2.375	1.438	1.641	0.594	0.500	13.0	N2-86-418	N2-28-3087X
1330 Series					A-3.875 B-1.063				
1330	2.000 x 0.120	1.766	1.375	1.656	0.594	0.500	9.0	N2-86-418	N2-28-3257X
1330	2.500 x 0.095	2.312	1.375	1.656	0.594	0.500	9.0	N2-86-418	N2-28-3277X
1330	3.000 x .083	2.844	1.375	1.656	0.594	0.500	9.0	N2-86-418	N2-28-3447X
1350 Series					A-3.875 B-1.188				
1350	3.000 x .083	2.844	1.469	1.734	0.594	0.500	15.0	N2-86-418	N3-28-1327-1X
1350	3.500 x .083	3.344	1.500	1.734	0.594	0.500	15.0	N2-86-418	N3-28-1527-1X
1350	2.750 x .083	2.594	1.469	1.734	0.594	0.500	15.0	N2-86-418	N3-28-1747-1X
1350	2.000 x 0.120	1.766	1.438	1.734	0.594	0.500	15.0	N2-86-418	N3-28-2947X
1350	2.500 x 0.095	2.312	1.438	1.734	0.594	0.500	15.0	N2-86-418	N3-28-3281X

CENTER & TUBE WELD YOKE

C.V. CENTERING YOKE

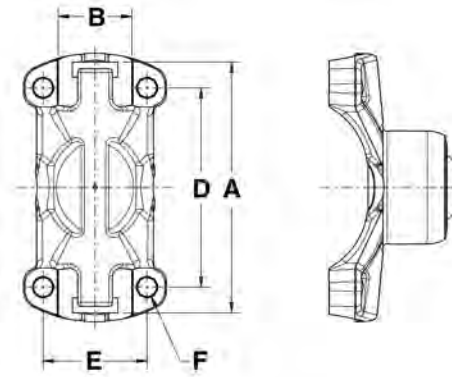

DL Series	D Bolt Hole Spacing Width	E Bolt Hole Spacing Length	F Hole/Thread Size	Stud Socket Dim.	Lubrication Type	Part Number
1310HR Series A-3.219 B-1.063						
1310HR	2.344	1.500	5/16-24	0.500	GREASABLE	7-0082
1310HR	2.344	1.500	5/16-24	0.500	NON-GREASABLE	7-0082NG
1330HR Series A-3.622 B-1.063						
1330HR	2.875	1.500	5/16-24	0.500	GREASABLE	7-0079
1330HR	2.875	1.500	5/16-24	0.500	NON-GREASABLE	7-0079NG
1350HR Series A-3.622 B-1.188						
1350HR	2.750	1.625	5/16-24	0.500	***	N3-83-019X

C.V. H YOKE - INSIDE LOCK-UP

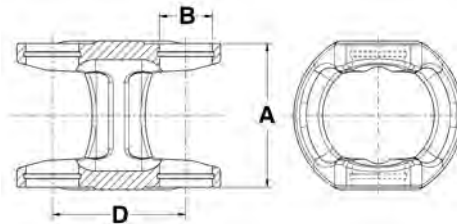

DL Series	D CL UJ to CL UJ	Maximum Joint Angle	Part Number
3R Series A-3.563 B-1.125 C-2.563			
3R	3.250	17.0	N3R-26-057

CENTER & TUBE WELD YOKE

C.V. H YOKE - OUTSIDE LOCK-UP

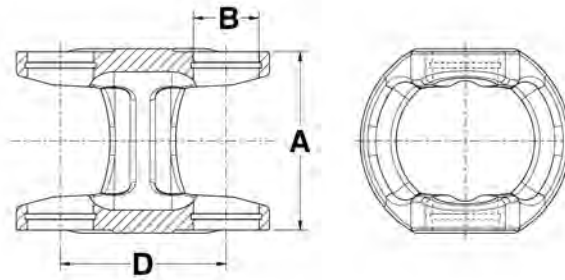

DL Series	D CL UJ to CL UJ	Maximum Joint Angle	Part Number
1310 Series A-3.469 B-1.063			
1310	2.688	26.0	N2-26-367
1330 Series A-3.875 B-1.063			
1330	2.750	18.0	N2-26-527
1410 Series A-4.438 B-1.188			
1410	3.480	***	N3-26-1410
1410	3.480	30.0	N3-26-1410HA
1350 Series A-3.875 B-1.188			
1350	2.875	30.0	N3-26-757

DOUBLE PIVOT YOKE

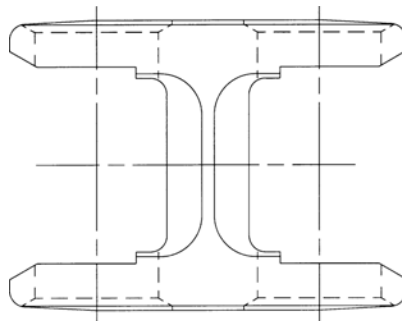

DL Series	D CL UJ To CL UJ	Joint Angle	Part Number
1000 Series A-2.312 B-0.938 C-1.500			
1000	1.690	7.000	10-5303
1000	2.500	18.000	10-5361
1200			
1200	3.380	***	12-1400
1200	2.380	***	12-1410
2200			
2200	2.130	***	22-2200
2200	7.250	***	22-2205

CENTER & TUBE WELD YOKE

TUBE WELD YOKE (Steel) - INSIDE LOCK-UP

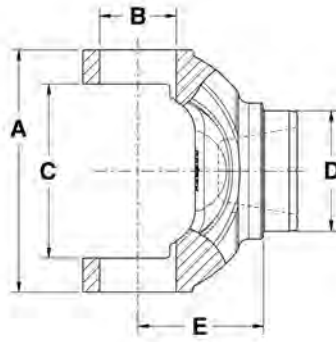

DL Series	Tubing Dia. And Wall	D Butt Dia.	Type Of Butt	E CL To Point Of Weld	Joint Angle	Part Number
1000 Series A-2.312 B-0.938 C-1.500						
1000	***	0.932	ID	2.105	***	NOE-04-2140-A
1000	0.75	0.745	ID	2.105	***	NOE-04-2143-A
1000	***	0.620	ID	2.105	***	NOE-04-2165-A
1000	T1.625-.065	1.503	OD	2.000	***	NOE-04-2107-A
1000	T1.500-.083	1.342	OD	2.000	***	NOE-04-2108-A
1000	T2.00-.083	1.842	OD	3.266	***	NOE-04-2128-A
1000	T1.259-.078	1.110	OD	1.797	***	NOE-04-6015-A
1000	T1.500-.065	1.379	OD	1.797	***	NOE-04-6016-A
1000	***	0.934	OD	2.264	***	NOE-04-6020-A
1000/0300 A-1.890 B-0.838 C-1.603						
1000/0300	T1.259-.078	1.110	OD	1.250	***	NOE-04-3870-A
3R Series A-3.563 B-1.125 C-2.563						
3R	4.000 X.065	3.875	HO	1.656	***	N3R-28-021
3R	3.000 X.095	2.812	HO	1.875	21.5	N3R-28-157
3R	2.000 X.120	1.766	HO	1.844	***	N3R-28-1757
3R	2.750 X.065	2.625	HO	1.750	20.0	N3R-28-307
3R	2.750 X.088	2.578	HO	1.797	***	N3R-28-309
3R	3.250 X.065	3.125	HO	1.875	21.5	N3R-28-325
3R	3.000 X.065	2.875	HO	1.875	21.5	N3R-28-327
3R	3.500 X.065	3.375	HO	1.875	21.5	N3R-28-397
3R	3.500 X.083	3.344	HO	1.875	21.5	N3R-28-427
3R	3.000 X.083	2.844	HO	1.875	21.5	N3R-28-437
7290 Series A-3.563 B-1.126 C-2.625						
7290	4.000 X.065	3.875	HO	1.656	***	N729-28-021
7290	2.750 X.065	2.625	HO	1.750	20.0	N729-28-307
7290	3.250 X.065	3.125	HO	1.875	21.5	N729-28-325
7290	3.500 X.065	3.375	HO	1.875	21.5	N729-28-397
7290	3.000 X.083	2.844	HO	1.875	21.5	N729-28-437

CENTER & TUBE WELD YOKE

TUBE WELD YOKE (Steel) - OUTSIDE LOCK-UP

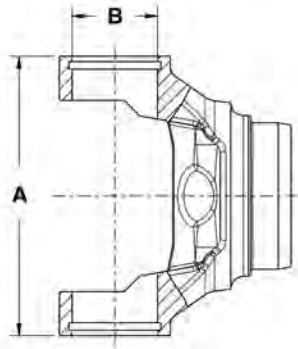

DL Series	Tubing Dia. And Wall	D Butt Dia.	Type Of Butt	E CL To Point Of Weld	Joint Angle	Part Number
1210 Series			A-2.56 B-1.063			
1210	2.500 X.065	2.375	HO	1.312	20.0	N2-28-1947
1210	2.000 X.083	1.844	HO	1.500	20.0	N2-28-2417
1310 Series			A-3.469 B-1.063			
1310	1.250 X.120	1.016	HO	2.125	30.0	N2-26-347
1310	2.750 X.083	2.594	HO	1.688	21.5	N2-28-1617
1310	2.000 X.120	1.766	HO	1.688	22.0	N2-28-1757
1310	2.500 X.065	2.375	HO	1.844	30.0	N2-28-277
1310	2.750 X.065	2.625	HO	1.688	21.5	N2-28-307
1310	3.000 X.065	2.875	HO	1.688	21.5	N2-28-327
1310	2.000 X.083	1.844	HO	1.688	22.0	N2-28-357
1310	2.500 X.083	2.344	HO	1.844	30.0	N2-28-367
1310	3.500 X.065	3.344	HO	1.688	21.5	N2-28-397
1310	2.000 X.065	1.875	HO	1.688	22.0	N2-28-417
1310	3.500 X.083	3.344	HO	1.688	21.5	N2-28-427
1310	3.000 X.083	2.844	HO	1.688	21.5	N2-28-437
1310	2.000 X.095	1.812	HO	1.688	22.0	N2-28-577
1330 Series			A-3.875 B-1.063			
1330	4.000 X.065	3.875	HO	1.875	22.0	N2-28-023
1330	3.000 X.065	2.875	HO	1.719	25.0	N2-28-1177
1330	3.000 X.083	2.844	HO	1.719	25.0	N2-28-1697
1330	2.500 X.083	2.344	HO	1.719	25.0	N2-28-1707
1330	3.500 X.083	3.344	HO	1.812	***	N2-28-1717
1330	3.500 X.065	3.375	HO	1.812	***	N2-28-1977
1330	4.000 X.083	3.844	HO	1.875	22.0	N2-28-3637

CENTER & TUBE WELD YOKE

TUBE WELD YOKE (Steel) - OUTSIDE LOCK-UP (Cont'd)

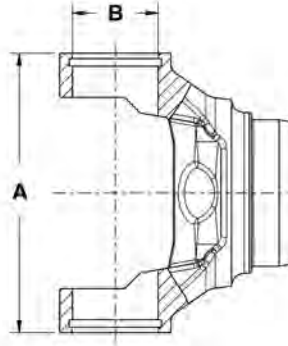

DL Series	Tubing Dia. And Wall	D Butt Dia.	Type Of Butt	E CL To Point Of Weld	Joint Angle	Part Number
1350 Series A-3.875 B-1.188						
1350	3.000 X.065	2.875	HO	2.000	20.0	N3-28-137
1350	3.000 X.095	2.820	HO	2.000	20.0	N3-28-157
1350	3.500 X.065	3.375	HO	1.812	20.0	N3-28-257
1350	4.000 X.083	3.844	HO	1.688	22.0	N3-28-417
1350	3.500 X.083	3.344	HO	1.812	20.0	N3-28-427
1350	2.500 X.083	2.344	HO	1.938	20.0	N3-28-47
1350	3.000 X.083	2.844	HO	2.000	20.0	N3-28-57
1350	2.750 X.095	2.562	HO	2.000	20.0	N3-28-57-1
1350	2.750 X.065	2.625	HO	2.000	20.0	N3-28-57-2
1410 Series A-4.438 B-1.188						
1410	3.500 X.065	3.375	HO	2.125	30.0	N3-28-367
1410	4.000 X.083	3.844	HO	1.875	22.0	N3-28-457
1410	3.500 X.083	3.344	HO	2.125	30.0	N3-28-557
1410	3.500 X.095	3.328	HO	2.125	30.0	N3-28-857
1410	3.000 X.083	2.844	HO	2.125	30.0	N3-28-97
1480 Series A-4.438 B-1.375						
1480	4.000 X.083	3.844	HO	2.031	22.5	N3-28-507
1480	3.500 X.083	3.344	HO	2.031	22.0	N3-28-537
1480	3.500 X.083	3.344	HO	2.312	35.0	N3-28-547
1480	3.500 X.134	3.250	HO	2.312	35.0	N3-28-548
1480	3.500 X.095	3.312	HO	2.031	22.0	N3-28-567
1550 Series A-5.250 B-1.375						
1550	3.500 X.095	3.328	HO	2.188	22.5	N4-28-307
1550	3.500 X.095	3.328	HO	2.688	35.0	N4-28-417

CENTER & TUBE WELD YOKE

PTO TUBE WELD YOKE (STEEL)-INSIDE LOCK UP

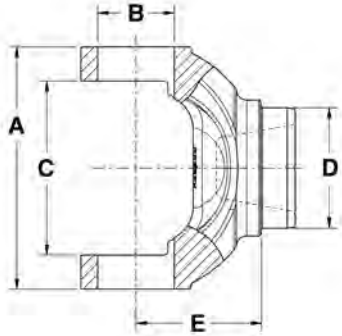

DL Series	Tubing Dia. And Wall	D Butt Dia.	Type Of Butt	E CL to Point of Weld	Joint Angle	Part Number
1000 Series			A-2.312	B-0.938	C-1.500	
1000	2.000 X.083	1.844	HO	2.156	***	10-1005
1000	1.750 X.065	1.625	SO	2.000	60.0	10-2817

PTO TUBE WELD YOKE (STEEL)-OUTSIDE LOCK UP

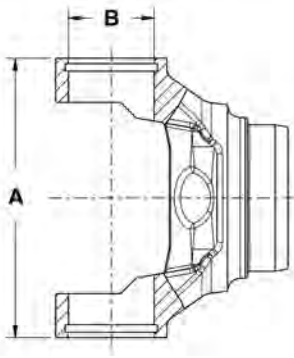

DL Series	Bore Size & Shape (in) (mm)	D Hub Dia. (in)	E CL To End Of Hub (in)	Part Number
2000 Series		A-2.625	B-1.125	C-1.85
2000	1.000 x 1.125 Rectangle	2.250	3.190	20-9126
2000	1.000 x 1.125 Rectangle	2.250	3.190	20-9129
2000	1.500 Round	1.842	4.000	20-9131
2000	1.1875 Square	2.250	3.190	20-9294
2000	1.281 x 1.408 Rectangle	2.250	3.190	20-9313

CENTER & TUBE WELD YOKE

BEARING PLATE CONSTRUCTION

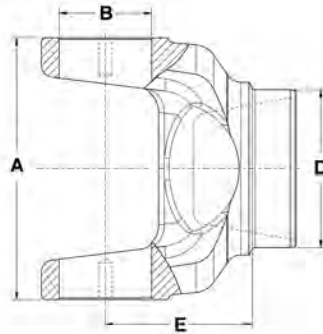

DL Series	Tubing Dia. And Wall	D Butt Dia.	E CL To Point Of Weld	Joint Angle	Type Of Butt	Part Number
1610 Series A-5.321 B-1.875						
1610	3.500 X.095	3.312	3.000	35.0	HO	N5-28-167
1610	4.000 X.134	3.750	3.000	***	HO	N5-28-327
1610	3.500 X.134	3.250	3.000	35.0	HO	N5-28-627
1710 Series A-6.094 B-1.938						
1710	3.500 X.156	3.188	3.031	22.0	HO	N6-28-137
1710	4.000 X.134	3.750	3.031	30/22.5	HO	N6-28-347
1710	4.500 X.134	4.250	3.031	22.0	HO	N6-28-407
1710	4.000 X.134	3.375	3.688	45.0	HO	N6-28-467
1760 Series A-7.000 B-1.938						
1760	4.095 X.180	3.750	3.031	30.0	HO	N6.3-28-17
1810 Series A-7.547 B-1.938						
1810	4.500 X.134	4.250	3.375	30.0	HO	N6.5-28-117
1810	4.500 X.259	4.000	3.375	30.0	HO	N6.5-28-127
20R Series A-7.250 B-2.060						
20R	4.095 X.180	3.750	3.703	30.0	HO	N20RY60-6
20R	4.095 X.180	3.750	5.250	39.0	HO	N20RY60-7
25R Series A-8.375 B-2.062						
25R	4.590 X.180	2.250	3.703	24.0	HO	N25RY68-3

CENTER & TUBE WELD YOKE

PLATELOCK CONSTRUCTION

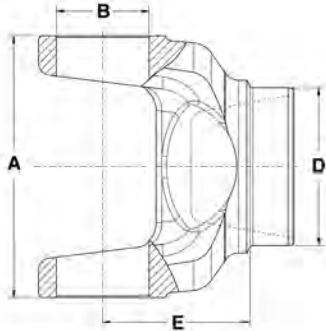

DL Series	Tubing Dia. And Wall	D Butt Dia.	Type Of Butt	E CL To Point Of Weld	Joint Angle	Part Number
NPL170/SPL170						
NPL170/SPL170 *	4.960 X.118	4.750	HO	3.688	25.0	N170-28-17
NPL170/SPL170 *	4.724 X.197	4.344	HO	4.734	45.0	N170-28-27
NPL170/SPL170 *	4.724 X.197	4.344 / 3.641	HO	4.734	45.0	N170-28-37
NPL250/SPL250						
NPL250/SPL250 *	5.196 X.236	4.750	HO	4.094	25.0	N250-28-17

* SPL - Spicer® Life Series driveshafts is a registered trademark of Dana Limited

CENTER & TUBE WELD YOKE

Notes

CENTER & TUBE WELD YOKE



THE DRIVELINE EXPERTS

Shafting/ Tubing/ Yoke & Tube Assembly

SUB SECTION

- Aux/PTO Solid Shaft-Round
- Aux/PTO Solid Shaft-Rectangular
- Aux/PTO Solid Shaft-Square
- Aux/PTO Solid Shaft-Hexagonal
- Aux/PTO Solid Shaft-Spilned
- Aux/PTO Shaft Tubing-Round
- Aux/PTO Tubing-Rectangular

**Manufacturing Driveline Solutions®
in the USA Since 1921.**

NeapcoAftermarket.com

SECTION

6



TUBING / YOKE & TUBE

AUX/PTO SOLID SHAFT - ROUND

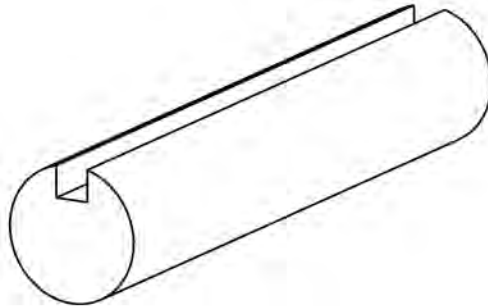

Dimen- sions	Keyway Dimen- sions	Length	Part Number
0.750 Round	0.188	72.0	71-0750
0.812 Round	0.250	72.0	71-0813
0.875 Round	0.250	72.0	71-0875
1.000 Round	0.250	72.0	71-1000
1.250 Round	0.312	72.0	71-1250

AUX/PTO SOLID SHAFT - RECTANGULAR

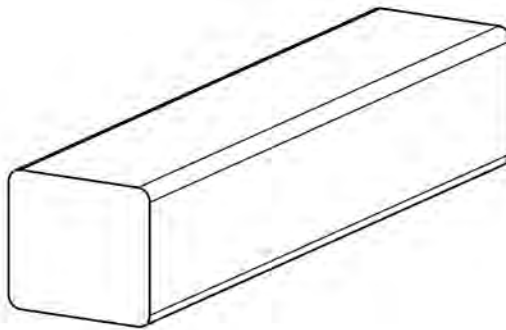

Dimensions	Length	Part Num- ber
0.750 x 0.875 Rectangle	72.0	73-0750
1.000 x 1.125 Rectangle	72.0	73-1001

TUBING / YOKE & TUBE

AUX/PTO SOLID SHAFT - SQUARE

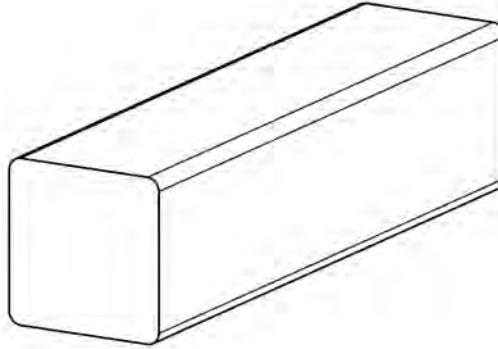

Dimensions	Length	Part Number
0.750 Square	72.0	72-0750
0.875 Square	72.0	72-0875
1.000 Square	72.0	72-1000
1.188 Square	72.0	73-1188
1.312 Square	72.0	73-1313

AUX/PTO SOLID SHAFT - HEXAGONAL

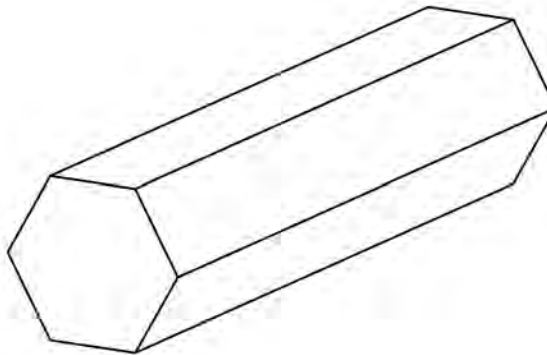

Dimensions	Length	Part Number
0.875 Hexagonal	72.0	72-0888
1.000 Hexagonal	72.0	72-1002
1.125 Hexagonal	72.0	72-1125

TUBING / YOKE & TUBE

AUX/PTO SOLID SHAFT - SPLINED

Dimensions	Length	Part Number
1.625-10 Spline	27.88	2231-3
1.000-15 Involute Spline	26.40	74-0115

AUX/PTO TUBING - ROUND

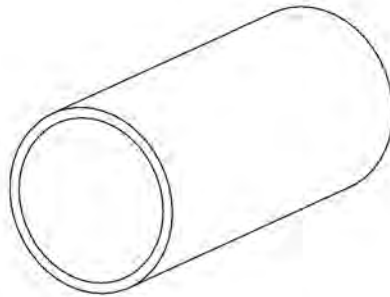

Tubing Type	Outside Dia.	Wall Thickness	Length	Shape	Part Number
Welded	1.620	0.065	72.0	Round	70-1625
Welded	2.000	0.083	72.0	Round	70-2000
Welded	2.120	0.120	72.0	Round	70-2125
Welded	2.250	0.120	72.0	Round	70-2250
Welded	2.500	0.134	72.0	Round	70-2500
Welded	2.750	0.109	72.0	Round	70-2750

TUBING / YOKE & TUBE

AUX/PTO TUBING - RECTANGULAR

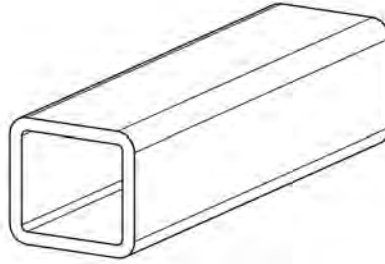

Outside Dia.	Wall Thickness	Length	Tubing Type	Part Number
1.000 x 1.125 Rectangle	0.125	72.0	Rectangular	70-1001
1.250 X 1.375 Rectangle	0.130	72.0	Rectangular	70-1250

DRIVE SHAFT TUBING - STEEL

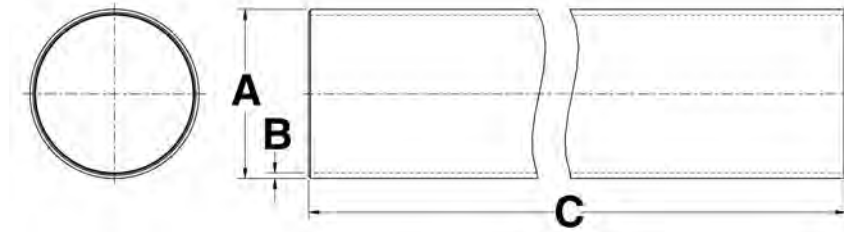

Tubing Type	A Outside Dia.	B Wall Thickness	C Length	Part Number
Welded	2.000	0.120	105.00	N16-30-102-108*
Welded	2.000	0.120	62.00	N16-30-102-62**
Welded	2.000	0.120	72.00	N16-30-102-72*
Welded	2.000	0.120	84.00	N16-30-102-84**
Welded	2.000	0.095	105.00	N16-30-42-108*
Welded	2.000	0.095	62.00	N16-30-42-62**
Welded	2.000	0.095	72.00	N16-30-42-72*
Welded	2.000	0.095	84.00	N16-30-42-84**
Welded	2.000	0.083	105.00	N16-30-62-108*
Welded	2.000	0.083	62.00	N16-30-62-62**
Welded	2.000	0.083	72.00	N16-30-62-72*
Welded	2.000	0.083	84.00	N16-30-62-84**
Welded	2.500	0.083	105.00	N20-30-22-108*
Welded	2.500	0.083	62.00	N20-30-22-62**
Welded	2.500	0.083	72.00	N20-30-22-72*

* 72" and 108" lengths will be discontinued once the current inventory is depleted.

** 62" and 84" tubes will be made available once current 72" and 108" lengths are depleted.

TUBING / YOKE & TUBE

DRIVE SHAFT TUBING - STEEL (Cont'd)

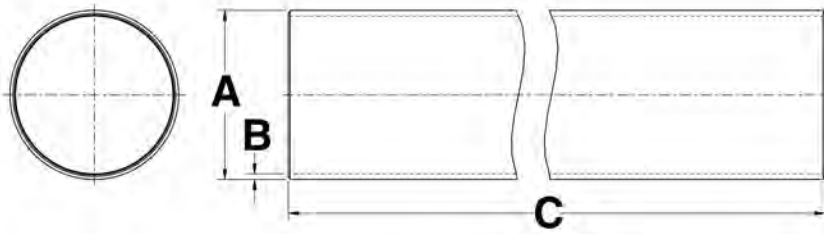

Tubing Type	A Outside Dia.	B Wall Thickness	C Length	Part Number
Welded	2.500	0.083	84.00	N20-30-22-84**
Welded	2.750	0.083	105.00	N22-30-22-108*
Welded	2.750	0.083	62.00	N22-30-22-62**
Welded	2.750	0.083	72.00	N22-30-22-72*
Welded	2.750	0.083	84.00	N22-30-22-84**
Welded	3.000	0.095	105.00	N24-30-12-108*
Welded	3.000	0.095	62.00	N24-30-12-62**
Welded	3.000	0.095	72.00	N24-30-12-72*
Welded	3.000	0.095	84.00	N24-30-12-84**
Welded	3.000	0.083	105.00	N24-30-42-108*
Welded	3.000	0.083	62.00	N24-30-42-62**
Welded	3.000	0.083	72.00	N24-30-42-72*
Welded	3.000	0.083	84.00	N24-30-42-84**
Welded	3.250	0.065	105.00	N26-30-12-108*
Welded	3.250	0.065	62.00	N26-30-12-62**
Welded	3.250	0.065	72.00	N26-30-12-72*
Welded	3.250	0.065	84.00	N26-30-12-84**
Welded	3.500	0.095	105.00	N28-30-22-108*
Welded	3.500	0.095	62.00	N28-30-22-62**
Welded	3.500	0.095	72.00	N28-30-22-72*
Welded	3.500	0.095	84.00	N28-30-22-84**
Welded	3.500	0.156	105.00	N28-30-52-108*
Welded	3.500	0.156	62.00	N28-30-52-62**
Welded	3.500	0.156	72.00	N28-30-52-72*
Welded	3.500	0.156	84.00	N28-30-52-84**
Welded	3.500	0.083	105.00	N28-30-62-108*
Welded	3.500	0.083	62.00	N28-30-62-62**
Welded	3.500	0.083	72.00	N28-30-62-72*
Welded	3.500	0.083	84.00	N28-30-62-84**
Welded	3.500	0.134	105.00	N28-30-92-108*
Welded	3.500	0.134	62.00	N28-30-92-62**
Welded	3.500	0.134	72.00	N28-30-92-72*
Welded	3.500	0.134	84.00	N28-30-92-84**

* 72" and 108" lengths will be discontinued once the current inventory is depleted.

** 62" and 84" tubes will be made available once current 72" and 108" lengths are depleted.

TUBING / YOKE & TUBE

DRIVE SHAFT TUBING - STEEL (Cont'd)

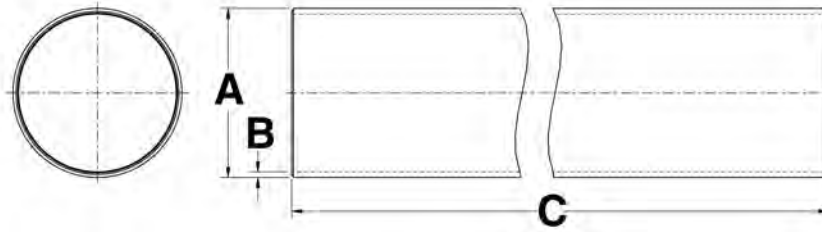

Tubing Type	A Outside Dia.	B Wall Thickness	C Length	Part Number
Welded	4.000	0.083	105.00	N32-30-22-108*
Welded	4.000	0.083	62.00	N32-30-22-62**
Welded	4.000	0.083	72.00	N32-30-22-72*
Welded	4.000	0.083	84.00	N32-30-22-84**
Welded	4.000	0.134	105.00	N32-30-52-108*
Welded	4.000	0.134	62.00	N32-30-52-62**
Welded	4.000	0.134	72.00	N32-30-52-72*
Welded	4.000	0.134	84.00	N32-30-52-84**
DOM	1.250	0.12	105.00	ND10-32-92-108*
DOM	1.250	0.12	62.00	ND10-32-92-62**
DOM	1.250	0.12	72.00	ND10-32-92-72*
DOM	1.250	0.12	84.00	ND10-32-92-84**
DOM	4.730	0.197	72.00	ND110-30-5-72*
DOM	4.980	0.12	72.00	ND120-30-3-72*
DOM	5.060	0.167	72.00	ND120-30-4-72*
DOM	5.120	0.197	72.00	ND120-30-5-72*
DOM	5.200	0.236	72.00	ND120-30-6-72*
DOM	2.000	0.12	105.00	ND16-30-102-108*
DOM	2.000	0.12	62.00	ND16-30-102-62**
DOM	2.000	0.12	72.00	ND16-30-102-72*
DOM	2.000	0.12	84.00	ND16-30-102-84**
DOM	2.000	0.065	105.00	ND16-30-32-108*
DOM	2.000	0.065	84.00	ND16-30-32-84**
DOM	2.000	0.083	105.00	ND16-30-62-108*
DOM	2.000	0.083	62.00	ND16-30-62-62**
DOM	2.000	0.083	72.00	ND16-30-62-72*
DOM	2.000	0.083	84.00	ND16-30-62-84**
DOM	2.500	0.065	105.00	ND20-30-12-108*
DOM	2.500	0.065	62.00	ND20-30-12-62**
DOM	2.500	0.065	72.00	ND20-30-12-72*
DOM	2.500	0.065	84.00	ND20-30-12-84**
DOM	2.500	0.083	105.00	ND20-30-22-108*
DOM	2.500	0.083	62.00	ND20-30-22-62**

* 72" and 108" lengths will be discontinued once the current inventory is depleted.

** 62" and 84" tubes will be made available once current 72" and 108" lengths are depleted.

TUBING / YOKE & TUBE

DRIVE SHAFT TUBING - STEEL (Cont'd)

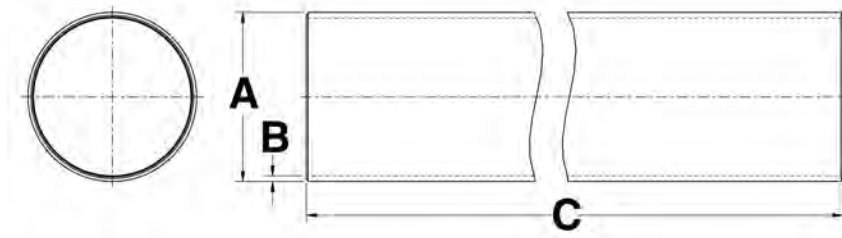

Tubing Type	A Outside Dia.	B Wall Thickness	C Length	Part Number
DOM	2.500	0.083	72.00	ND20-30-22-72*
DOM	2.500	0.083	84.00	ND20-30-22-84**
DOM	2.500	0.095	105.00	ND20-30-52-108*
DOM	2.500	0.095	84.00	ND20-30-52-84**
DOM	2.500	0.120	62.00	ND20-30-62-62**
DOM	2.500	0.120	72.00	ND20-30-62-72*
DOM	2.750	0.065	105.00	ND22-30-12-108*
DOM	2.750	0.065	62.00	ND22-30-12-62**
DOM	2.750	0.065	72.00	ND22-30-12-72*
DOM	2.750	0.065	84.00	ND22-30-12-84**
DOM	2.750	0.083	105.00	ND22-30-22-108*
DOM	2.750	0.083	62.00	ND22-30-22-62**
DOM	2.750	0.083	72.00	ND22-30-22-72*
DOM	2.750	0.083	84.00	ND22-30-22-84**
DOM	3.000	0.065	105.00	ND24-30-32-108*
DOM	3.000	0.065	62.00	ND24-30-32-62**
DOM	3.000	0.065	72.00	ND24-30-32-72*
DOM	3.000	0.065	84.00	ND24-30-32-84**
DOM	3.000	0.083	105.00	ND24-30-42-108*
DOM	3.000	0.083	62.00	ND24-30-42-62**
DOM	3.000	0.083	72.00	ND24-30-42-72*
DOM	3.000	0.083	84.00	ND24-30-42-84**
DOM	3.500	0.065	105.00	ND28-30-42-108*
DOM	3.500	0.065	62.00	ND28-30-42-62**
DOM	3.500	0.065	72.00	ND28-30-42-72*
DOM	3.500	0.065	84.00	ND28-30-42-84**
DOM	3.500	0.083	105.00	ND28-30-62-108*
DOM	3.500	0.083	62.00	ND28-30-62-62**
DOM	3.500	0.083	72.00	ND28-30-62-72*
DOM	3.500	0.083	84.00	ND28-30-62-84**
DOM	4.000	0.095	105.00	ND32-30-12-108*
DOM	4.000	0.095	62.00	ND32-30-12-62**

* 72" and 108" lengths will be discontinued once the current inventory is depleted.

** 62" and 84" tubes will be made available once current 72" and 108" lengths are depleted.

TUBING / YOKE & TUBE

DRIVE SHAFT TUBING - STEEL (Cont'd)

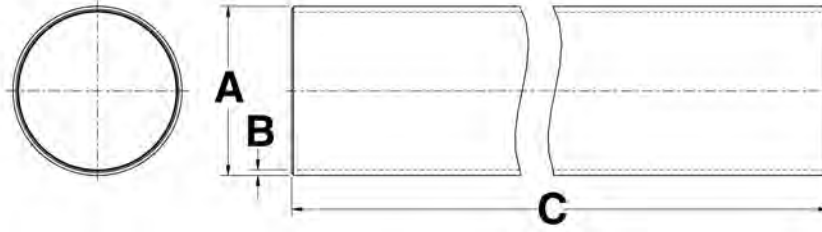

Tubing Type	A Outside Dia.	B Wall Thickness	C Length	Part Number
DOM	4.000	0.095	72.00	ND32-30-12-72*
DOM	4.000	0.095	84.00	ND32-30-12-84**
DOM	4.000	0.083	105.00	ND32-30-22-108*
DOM	4.000	0.083	62.00	ND32-30-22-62**
DOM	4.000	0.083	72.00	ND32-30-22-72*
DOM	4.000	0.083	84.00	ND32-30-22-84**
DOM	4.095	0.18	105.00	ND32-30-72-108*
DOM	4.095	0.18	72.00	ND32-30-72-72*
DOM	4.590	0.18	105.00	ND36-30-102-108*
DOM	4.590	0.18	62.00	ND36-30-102-62**
DOM	4.590	0.18	72.00	ND36-30-102-72*
DOM	4.590	0.18	84.00	ND36-30-102-84**
DOM	4.500	0.259	105.00	ND36-30-22-108*
DOM	4.500	0.259	62.00	ND36-30-22-62**
DOM	4.500	0.259	72.00	ND36-30-22-72*
DOM	4.500	0.259	84.00	ND36-30-22-84**
DOM	4.500	0.134	105.00	ND36-30-62-108*
DOM	4.500	0.134	62.00	ND36-30-62-62**
DOM	4.500	0.134	72.00	ND36-30-62-72*
DOM	4.500	0.134	84.00	ND36-30-62-84**
DOM	1.259	0.078	43.38	NOE-07-125-078-A
DOM	1.500	0.065	43.38	NOE-07-150-065-A
DOM	1.500	0.083	37.00	NOE-07-150-083-A
DOM	1.625	0.065	48.01	NOE-07-162-065-A
DOM	2.000	0.083	53.35	NOE-07-200-083-A
DOM	4.000	0.065	72.00	TD-143

* 72" and 108" lengths will be discontinued once the current inventory is depleted.

** 62" and 84" tubes will be made available once current 72" and 108" lengths are depleted.

TUBING / YOKE & TUBE

YOKE & TUBE ASSEMBLY

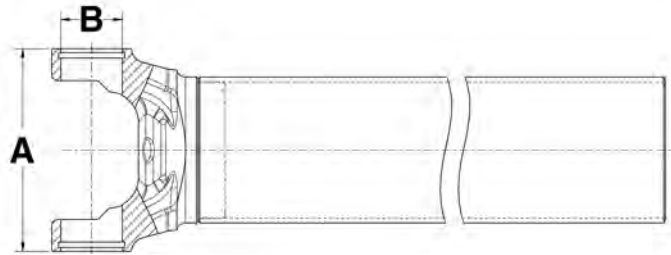

DL Series	Dia. and Wall Thickness	D Center To End Of Tube	Part Number
1310 Series A-3.469 B-1.063			
1310	3.000 X .083	49.688	N2-27-24-4800
1310	3.000 X .083	61.688	N2-27-24-6000
1310	2.000 X .083	49.438	N2-27-7-4724
1310	2.500 X .083	62.375	N2-27-9-6017
1330 Series A-3.875 B-1.063			
1330	3.000 X .083	61.719	N2-27-30-6000
1330	3.500 X .083	73.812	N2-27-35-7200
1350 Series A-3.875 B-1.188			
1350	3.000 X .083	66.000	N3-27-2-6400
1350	3.500 X .083	73.812	N3-27-7-7200
1410 Series A-4.438 B-1.188			
1410	3.000 X .083	65.031	N3-27-3-6229
1410	3.500 X .083	73.812	N3-27-4-7200
1480 Series A-4.438 B-1.375			
1480	3.500 X .083	63.344	N3-27-22-6110

PTO TUBING

Tube Type	Tube Profile/ shape	DL Series	Outside Dia.	Wall Thick-ness	Length	Part Number
B&P1						
Outer Profile	Benzi	B&P1	1.280	0.093	59.0	70-0104
Inner Profile	Benzi	B&P1	1.040	0.140	59.0	70-0105

TUBING / YOKE & TUBE

PTO TUBING (Cont'd)

Tube Type	Tube Profile/ shape	DL Series	Outside Dia.	Wall Thick- ness	Length	Part Number
B&P2						
Inner Profile	Benzi	B&P2	1.140	0.156	59.0	70-0205
B&P3						
Outer Profile	Benzi	B&P3	1.420	0.125	59.0	70-0305
B&P4						
Inner Profile	Benzi	B&P4	1.420	0.171	59.0	70-0405
Outer Profile	Benzi	B&P4	1.700	0.125	59.0	70-0304
B&P5						
Outer Profile	Benzi	B&P5	2.010	0.109	59.0	70-0504
B&P6						
Inner Profile	Benzi	B&P6	1.760	0.156	59.0	70-0505
B&P7						
Inner Profile	Benzi	B&P7	1.750	0.218	59.0	70-0705
B&P8						
Outer Profile	Benzi	B&P8	2.100	0.156	59.0	70-0704
Outer Profile	Benzi	B&P8	2.500	0.156	59.0	70-0804
W2100						
Outer Profile	Lemon	W2100	1.180	0.109	59.0	70-2104
Inner Profile	Lemon	W2100	0.920	0.140	59.0	70-2105
W2400						
Outer Profile	Lemon	W2400	1.890	0.156	59.0	70-2404
Inner Profile	Lemon	W2400	1.560	0.171	59.0	70-2405
W2500						
Outer Profile	Star	W2500	2.400	0.171	59.0	70-2504
Inner Profile	Star	W2500	2.000	***	59.0	70-2505
WI						
Outer Profile	Lemon	WI	1.620	0.109	59.0	70-2204
Inner Profile	Lemon	WI	1.350	0.156	59.0	70-2205

TUBING / YOKE & TUBE

TUBING / YOKE & TUBE

PTO YOKE AND U-JOINT ASSEMBLY

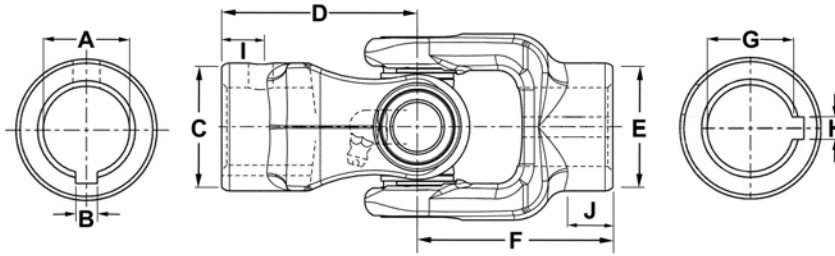

DL Series	U-joint	A Yoke 1 Bore Size & Shape	B Yoke 1 Keyway Width	C Yoke 1 Hub Dia.	D Yoke 1 CL To End Of Hub	E Yoke 2 Hub Dia.	F Yoke 2 CL To End Of Hub	G Yoke 2 Bore Size & Shape	Yoke 1 Set Screw Thread Size
1000 Series A-2.312 B-0.938 C-1.500									
1000	1-0170	0.750 Round	0.251	***	2.500	***	2.500	0.750 Round	3/8-16 UNC 2B
1000	1-0170	0.750 Round	0.188	***	2.500	***	2.500	0.750 Round	3/8-16 UNC 2B (2)
1000	1-0170	0.750 Round	0.188	***	2.500	***	2.500	0.750 Round	3/8-16 UNC 2B
1000	1-0170	0.750 Round	0.188	***	2.500	***	2.500	1.127 Hexagonal	3/8-16 UNC 2B
1000	1-0170	0.750 Round	0.251	***	2.500	***	2.500	0.813 Round	3/8-16 UNC 2B
1000	1-0170	0.813 Round	0.251	1.630	2.500	1.630	2.500	0.750 Square	3/8-16 UNC 2B
1000	1-0170	0.813 Round	0.251	***	2.500	***	2.500	0.813 Round	3/8-16 UNC 2B
1000	1-0170	0.813 Round	0.251	***	5.500	***	2.500	0.813 Round	Fitting
1000	1-0170	0.875 Round	0.188	***	2.500	***	2.500	0.875 Round	3/8-16 UNC 2B
1000	1-0170	0.875 Round	0.251	***	2.500	***	2.500	0.875 Round	3/8-16 UNC 2B
1000	1-0170	0.875 Round	0.251	***	2.500	***	2.500	1.000 Round	3/8-16 UNC 2B
1000	1-0170	0.875 Round	0.251	***	5.500	***	2.500	0.875 Round	3/8-16 UNC 2B
1000	1-0170	0.875 Round	0.188, 0.251	***	2.500	***	2.500	0.875 Round	3/8-16 UNC 2B
1000	1-0170	0.875 Square	***	***	2.500	***	2.500	1.000 Round	3/8-16 UNC 2B
1000	1-0170	0.875 Square	***	***	2.500	***	2.500	1.000 Round	3/8-16 UNC 2B
1000	1-0170	0.876 Round	***	1.630	2.500	1.630	2.500	0.876 Round	7/16-20 UNF
1000	1-0170	0.879 Square	***	***	5.500	***	2.500	1.000 Round	Fitting
1000	1-0170	0.938 Round	0.251	***	2.500	***	2.500	0.938 Round	3/8-16 UNC 2B
1000	1-0170	1.000 Round	0.251	1.630	2.500	1.630	2.500	1.000 Round	3/8-16 UNC 2B
1000	1-0170	1.000 Round	0.251	***	2.500	***	2.500	1.250 Round	3/8-16 UNC 2B
1000	1-0170	1.000 Round	***	***	2.500	***	2.500	1.000 Round	0.380 DT
1000	1-0170	1.000 Round	0.251	***	5.500	***	2.500	1.250 Round	Fitting
1000	1-0170	1.000 Round	0.251	***	2.500	***	2.500	1.000 Round	3/8-16 UNC 2B
1000	1-0170	1.000 Round	0.251	***	5.500	***	2.500	1.000 Round	Fitting
1000	1-0170	1.000 Round	0.188, 0.251	***	2.500	***	2.500	1.000 Round	3/8-16 UNC 2B
1000	1-0170	1.000 Round	0.251	***	2.500	***	5.500	0.750 x 0.880 Rectangle	3/8-16 UNC 2B

PTO YOKE AND U-JOINT ASSEMBLY

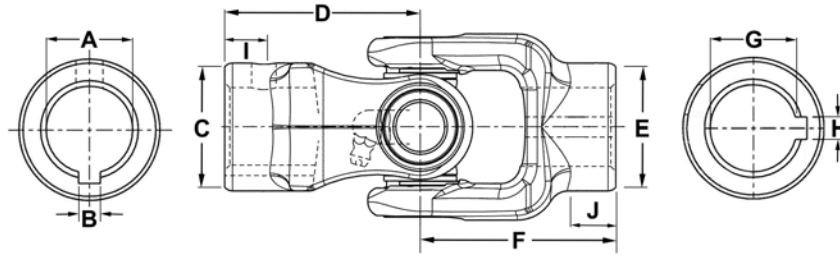

H Yoke 2 Keyway Width	I Yoke 1 End Of Hub To Set Screw	J Yoke 2 End Of Hub To Set Screw	Yoke 1 Keyway Location	Yoke 1 Set Screw Location	Yoke 1 Set Screw Thread Size	Yoke 2 Keyway Location	Yoke 2 Set Screw Location	Yoke 2 Set Screw Thread Size	Part Number
1000 Series A-2.312 B-0.938 C-1.500									
0.251	0.500	0.500	Gap	Gap	3/8-16 UNC 2B	Gap	Gap	3/8-16 UNC 2B	11-2004
0.188	0.500	0.500	Gap	Ear	3/8-16 UNC 2B (2)	Gap	Ear	3/8-16 UNC 2B (2)	11-2005
0.188	0.500	0.500	Gap	Gap	3/8-16 UNC 2B	Gap	Gap	3/8-16 UNC 2B	11-2018
***	0.500	0.500	Gap	Gap	3/8-16 UNC 2B	***	Gap	3/8-16 UNC 2B	11-2033
0.251	0.500	0.500	Gap	Gap	3/8-16 UNC 2B	Gap	Gap	3/8-16 UNC 2B	11-2049
***	0.500	0.500	Gap	Gap	3/8-16 UNC 2B	***	Gap	3/8-16 UNC 2B	11-1619
0.251	0.500	0.500	Gap	Gap	3/8-16 UNC 2B	Gap	Gap	3/8-16 UNC 2B	11-2003
0.251	1.750	0.500	Gap	Gap	Fitting	Gap	Gap	3/8-16 UNC 2B	11-3002
0.188	0.500	0.500	Gap	Gap	3/8-16 UNC 2B	Gap	Gap	3/8-16 UNC 2B	11-2002
0.251	0.500	0.500	Gap	Gap	3/8-16 UNC 2B	Gap	Gap	3/8-16 UNC 2B	11-2016
0.251	0.500	0.500	Gap	Gap	3/8-16 UNC 2B	Gap	Gap	3/8-16 UNC 2B	11-2042
0.251	1.750	0.500	Gap	Gap	3/8-16 UNC 2B	Gap	Gap	3/8-16 UNC 2B	11-3025
0.188, 0.251	0.500	0.500	Gap	Ear	3/8-16 UNC 2B	Gap	Ear	3/8-16 UNC 2B	11-3980
0.251	0.630	0.500	***	Gap	3/8-16 UNC 2B	Gap	Gap	3/8-16 UNC 2B	11-1647
0.250	0.630	0.500	***	Gap	3/8-16 UNC 2B	Gap	Ear	3/8-16 UNC 2B	11-1893
***	0.500	0.500	***	Ear	7/16-20 UNF	***	Ear	7/16-20 UNF	11-0002
0.250	1.750	0.500	***	Gap	Fitting	Gap	Ear	3/8-16 UNC 2B	11-1881
0.251	0.500	0.500	Ear	Ear	3/8-16 UNC 2B	Ear	Ear	3/8-16 UNC 2B	11-2006
0.251	0.500	0.500	Gap	Ear	3/8-16 UNC 2B	Gap	Ear	3/8-16 UNC 2B	11-1400
0.313	0.500	0.500	Gap	Gap	3/8-16 UNC 2B	Gap	Gap	3/8-16 UNC 2B	11-1623
***	0.500	0.500	***	Ear	0.380 DT	***	Ear	0.380 DT	11-1672
***	1.750	0.500	Gap	Gap	Fitting	***	Ear	0.380 DT	11-1751
0.251	0.500	0.500	Gap	Gap	3/8-16 UNC 2B	Gap	Gap	3/8-16 UNC 2B	11-2007
0.251	1.750	0.500	Gap	Gap	Fitting	Gap	Gap	3/8-16 UNC 2B	11-3018
0.188, 0.251	0.500	0.500	Gap	Ear	3/8-16 UNC 2B	Gap	Ear	3/8-16 UNC 2B	11-3985
***	0.500	1.000	Gap	Gap	3/8-16 UNC 2B	***	Gap	90 degree fitting	11-3989

TUBING / YOKE & TUBE

PTO YOKE AND U-JOINT ASSEMBLY (Cont'd)

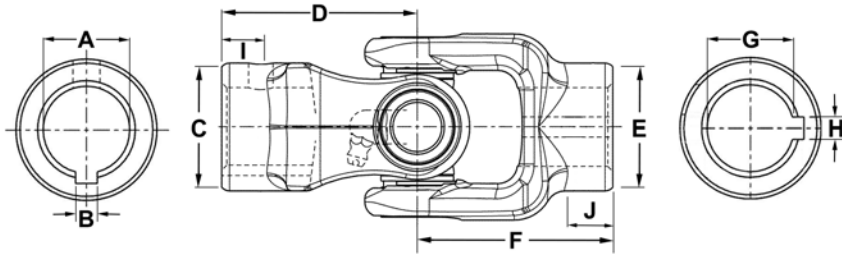

DL Series	U-joint	A Yoke 1 Bore Size & Shape	B Yoke 1 Keyway Width	C Yoke 1 Hub Dia.	D Yoke 1 CL To End Of Hub	E Yoke 2 Hub Dia.	F Yoke 2 CL To End Of Hub	G Yoke 2 Bore Size & Shape	Yoke 1 Set Screw Thread Size
1000 Series A-2.312 B-0.938 C-1.500									
1000	1-0170	1.125 Round	0.251	***	2.500	***	2.500	1.125 Round	3/8-16 UNC 2B
1000	1-0170	1.125 Round	0.313	***	2.500	***	2.500	1.125 Round	3/8-16 UNC 2B
1000	1-0170	1.125 Round	0.251, 0.313	***	2.500	***	2.500	1.125 Round	3/8-16 UNC 2B
1000	1-0170	1.127 Hexagonal	***	***	2.500	***	2.500	1.125 Round	3/8-16 UNC 2B
1000	1-0170	1.127 Hexagonal	***	***	2.500	***	2.500	1.000 Round	3/8-16 UNC 2B
1000	1-0170	1.127 Hexagonal	***	***	2.500	***	2.500	1.250 Round	3/8-16 UNC 2B
1000	1-0170	1.127 Hexagonal	***	***	2.500	***	1.560	Flange Yoke	3/8-16 UNC 2B
1000	1-0170	1.129 Hexagonal	***	***	5.500	***	2.500	1.250 Round	3/8-16 UNC 2B
1000	1-0170	1.129 Hexagonal	***	***	5.500	***	2.500	0.875 Round	3/8-16 UNC 2B
1000	1-0170	1.129 Hexagonal	***	***	5.500	***	1.560	Flange Yoke	3/8-16 UNC 2B
1000	1-0170	1.250 Round	0.313	***	2.500	***	2.500	1.250 Round	3/8-16 UNC 2B
1000	1-0170	1.250 Round	0.313	***	5.500	***	2.500	1.250 Round	Fitting
1000	1-0170	1.250 Round	0.251, 0.313	***	2.500	***	2.500	1.250 Round	3/8-16 UNC 2B
1200 Series A-2.562 B-1.063 C-1.812									
1200	1-1275	0.750 Round	0.188	***	2.750	***	2.750	0.750 Round	3/8-16
1200	1-1275	0.875 Round	0.251	***	2.750	***	2.750	0.876 Round	3/8-16
1200	1-1275	1.000 Round	0.188	***	3.500	***	3.500	1.000 Round	3/8-16
1200	1-1275	1.125 Round	0.251, 0.313	***	3.500	***	3.500	1.125 Round	3/8-16
1200	1-1275	1.249 Square	n/a	***	2.750	***	2.750	1.249 Square	0.340 DT
1200	1-1275	1.250 Round	0.251	***	2.750	***	2.750	1.250 Round	3/8-16
1200	1-1275	1.250 Round	***	***	2.630	***	2.750	1.000 Square	0.450 DT
1200	1-1275	1.250 Round	0.313	***	3.250	***	3.250	1.250 Round	3/8-16 BH
1200	1-1275	1.438 Round	0.376	***	3.000	***	2.750	1.249 Square	3/8-16 UNC 2B (2)
1200	1-1275	1.500 Round	0.376	***	2.750	***	2.750	1.500 Round	3/8-16 (2)

TUBING / YOKE & TUBE

PTO YOKE AND U-JOINT ASSEMBLY (Cont'd)

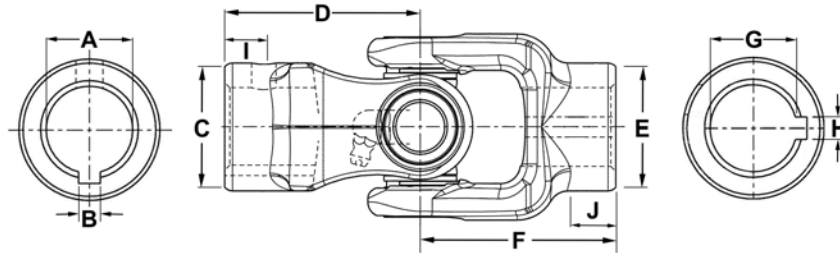

H Yoke 2 Keyway Width	I Yoke 1 End Of Hub To Set Screw	J Yoke 2 End Of Hub To Set Screw	Yoke 1 Keyway Location	Yoke 1 Set Screw Location	Yoke 1 Set Screw Thread Size	Yoke 2 Keyway Location	Yoke 2 Set Screw Location	Yoke 2 Set Screw Thread Size	Part Number
1000 Series A-2.312 B-0.938 C-1.500									
0.251	0.500	0.500	***	***	3/8-16 UNC 2B	***	***	3/8-16 UNC 2B	11-1609
0.313	0.500	0.500	Gap	Gap	3/8-16 UNC 2B	Gap	Gap	3/8-16 UNC 2B	11-2009
0.251, 0.313	0.500	0.500	Gap	Ear	3/8-16 UNC 2B	Gap	Ear	3/8-16 UNC 2B	11-3986
0.251	0.500	0.500	***	Gap	3/8-16 UNC 2B	Gap	Gap	3/8-16 UNC 2B	11-1627
0.188	0.500	0.500	***	Gap	3/8-16 UNC 2B	Gap	Ear	3/8-16 UNC 2B	11-2035
0.313	0.500	0.500	***	Gap	3/8-16 UNC 2B	Gap	Gap	3/8-16 UNC 2B	11-2036
***	0.500	***	***	Gap	3/8-16 UNC 2B	***	***	2.250 Male Pilot, 2.750 Bolt Circle	11-6832
0.313	1.750	0.500	***	Gap	3/8-16 UNC 2B	Gap	Gap	3/8-16 UNC 2B	11-3009
0.251	1.750	0.500	***	Gap	3/8-16 UNC 2B	Gap	Gap	3/8-16 UNC 2B	11-3065
***	1.750	***	***	Gap	3/8-16 UNC 2B	***	***	2.250 Male Pilot, 2.750 Bolt Circle	11-6831
0.313	0.500	0.500	Gap	Gap, Ear	3/8-16 UNC 2B	Gap, Ear	Gap	3/8-16 UNC 2B	11-2008
0.313	1.750	0.500	Gap	Gap	Fitting	Gap	Gap	3/8-16 UNC 2B	11-3092
0.251, 0.313	0.500	0.500	Gap (2)	Ear	3/8-16 UNC 2B	Gap (2)	Ear	3/8-16 UNC 2B	11-3990
1200 Series A-2.562 B-1.063 C-1.812									
0.188	0.630	0.630	Ear	Gap	3/8-16	Ear	Gap	3/8-16	13-8488
0.251	0.630	0.630	Ear	Gap	3/8-16	Ear	Gap	3/8-16	13-5995
0.188	0.880	0.880	Ear	Gap	3/8-16	Ear	Gap	3/8-16	13-6075
0.251, 0.313	0.880	0.880	Ear	Gap	3/8-16	Ear	Gap	3/8-16	13-6780
n/a	0.630	0.630	n/a	Gap	0.340 DT	n/a	Gap	0.340 DT	13-8675
0.251	0.630	0.630	Gap	Ear	3/8-16	Gap	Ear	3/8-16	13-6201
***	0.630	0.750	***	Gap	0.450 DT	***	Gap	0.316 DT	13-6475
0.313	0.630	0.630	Ear	Clamp	3/8-16 BH	Ear	Clamp	3/8-16 BH	13-8868
***	0.630	0.630	Gap	Ear, Gap	3/8-16 UNC 2B (2)	***	Gap	0.340 DT	13-9119
0.376	0.630	0.630	Gap	Ear, Gap	3/8-16 (2)	Gap	Ear, Gap	3/8-16 UNC 2B (2)	13-7080

TUBING / YOKE & TUBE

PTO YOKE AND TUBE ASSEMBLY

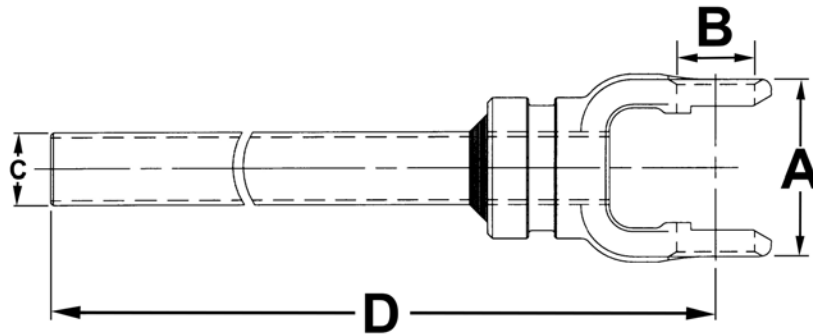

DL Series	C Tube Dia. & Wall Thickness	D CL To End Of Tube	Part Number
1000 Series A-2.312 B-0.938 C-1.500			
1000	0.750 x 0.875 Rectangle	24.00	65-0627
1000	0.750 x 0.875 Rectangle	36.00	65-0639
1000	0.750 x 0.875 Rectangle	48.00	65-0651
1000	1.000 x 1.125 Rectangle	24.00	64-0627
1000	1.000 x 1.125 Rectangle	36.00	64-0639
1000	1.000 x 1.125 Rectangle	48.00	64-0651
1200 Series A-2.562 B-1.063 C-1.812			
1200	1.000 x 1.125 Rectangle	24.00	65-2827
1200	1.000 x 1.125 Rectangle	36.00	65-2839
1200	1.000 x 1.125 Rectangle	47.90	65-2851
1200	1.280 x 1.410 Rectangle	24.00	64-2727
1200	1.280 x 1.410 Rectangle	36.00	64-2739
1200	1.280 x 1.410 Rectangle	48.00	64-2751
1800 Series B-1.00 C-2.34			
1800	1.000 x 1.125 Rectangle	24.00	65-1828
1800	1.000 x 1.125 Rectangle	36.00	65-1840
1800	1.000 x 1.125 Rectangle	48.00	65-1852
1800	1.300 x 1.420 Rectangle	24.00	64-1828
1800	1.300 x 1.420 Rectangle	36.00	64-1840
1800	1.300 x 1.420 Rectangle	48.00	64-1852
2000 Series A-2.625 B-1.125 C-1.85			
2000	1.000 x 1.125 Rectangle	24.76	64-2728
2000	1.000 x 1.125 Rectangle	36.57	64-2740
2000	1.000 x 1.125 Rectangle	48.57	64-2752
2000	1.000 x 1.125 Rectangle	23.60	65-2828
2000	1.000 x 1.125 Rectangle	35.75	65-2840

TUBING / YOKE & TUBE

PTO YOKE AND TUBE ASSEMBLY (Cont'd)

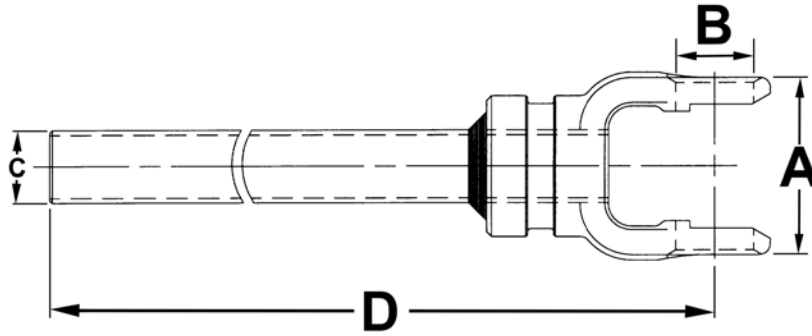

TUBING / YOKE & TUBE

DL Series	C Tube Dia. & Wall Thickness	D CL To End Of Tube	Part Number
2200 Series A-3.218 B-1.250 C-2.06			
2200	1.187 Square	24.62	64-2529
2200	1.187 Square	35.12	64-2539
2200	1.187 Square	47.12	64-2551
2200	1.187 X 1.187 Square	23.90	65-2629
2200	1.187 X 1.187 Square	33.90	65-2639
2600 Series B-1.37 C-2.81			
2600	1.312 Square	24.00	64-6529
2600	1.312 Square	33.38	64-6539
2600	1.312 Square	46.13	64-6551
2600	1.312 Square	23.60	65-6629
2600	1.312 Square	34.25	65-6639
N44 Series B-1.31 C-2.79			
N44	1.312 Square	24.13	64-4424
N44	1.312 Square	34.63	64-4435
N44	1.312 Square	46.07	64-4447
N44	1.312 Square	22.90	65-4423
N44	1.312 Square	35.40	65-4435

TUBING / YOKE & TUBE

Notes



THE DRIVELINE EXPERTS

Stub Shaft

SUB SECTION

CV Flange Stub

Splined Mid-Ship - Outboard Slip Yokes

Mid-Ship Cap Screw & Shaft Nut Type

Slip Stub Shaft

PTO Stub Shaft

SECTION

7



**Manufacturing Driveline Solutions®
in the USA Since 1921.**

NeapcoAftermarket.com

©Neapco LLC 2023

STUB SHAFT

CV FLANGE STUB

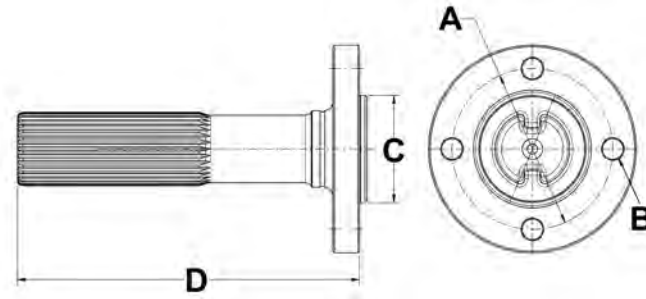

DL Series	Spline/ Number Teeth	A Bolt Circle	B Hole/ Thread Size	Number Of Bolt Holes	C Pilot Dia.	D Flange Face To End	Part Number
1310 Series				A-3.469 B-1.063			
1310	1.375-32	3.000	0.375	4	2.000-M	6.375	N2-81-1181

SPLINED MID-SHIP - OUTBOARD SLIP YOKES

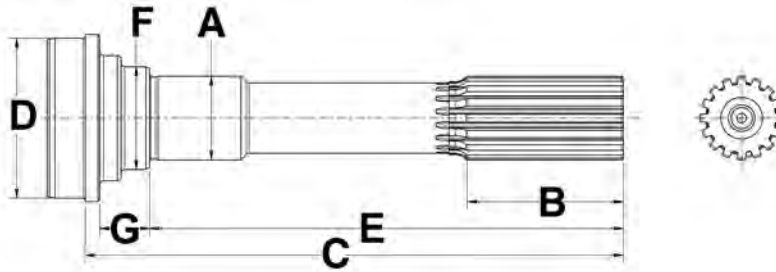

Spline/Number Teeth	A Bearing Dia.	Tubing Dia. And Wall	B Length Of Spline	C End Of Spline To Point Of Weld	D Butt Dia.	E End Of Spline To Brg. Shoulder	F Shoulder Dia.	G Length Of Shoulder	Part Number
1.375-16	1.378	2.500 X .083	5.406	8.000	2.344	6.938	1.688	0.812	N2-53-471
1.375-16	1.378	3.000 X .065	5.406	8.000	2.875	6.938	1.688	0.812	N2-53-491
1.375-16	1.378	3.000 X .083	5.406	8.000	2.844	6.938	1.688	0.812	N2-53-501
1.375-15/16	1.378	3.000 X .065	2.500	8.844	2.875	7.781	1.688	0.812	N2-53-691
1.375-15/16	1.378	3.000 X .083	2.500	8.844	2.844	7.781	1.688	0.812	N2-53-711
1.375-15/16	1.378	2.750 X .065	2.500	8.844	2.625	7.781	1.688	0.812	N2-53-711-1
1.375-16	***	2.750 X .065	2.500	8.844	2.625	***	***	***	N2-53-9170-2
1.375-16	***	1.620 X .205	2.500	9.000	1.219	7.469	***	***	N2-53-9170-5
1.500-16	1.575	3.000 X .083	4.438	7.062	2.844	5.938	1.812	0.875	N3-53-1031
1.375-31/32	1.378	3.000 X .083	3.375	8.812	2.844	7.469	1.719	1.125	N3-53-1181
1.375-31/32	1.378	2.750 X .095	3.375	8.812	2.578	7.469	1.719	1.125	N3-53-1181-1

STUB SHAFT

SPLINED MID-SHIP - OUTBOARD SLIP YOKES (Cont'd)

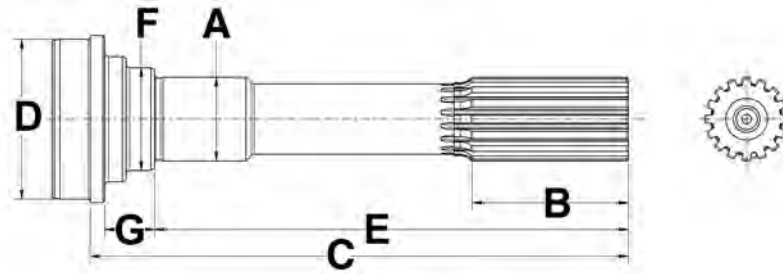

Spline/Number Teeth	A Bearing Dia.	Tubing Dia. And Wall	B Length Of Spline	C End Of Spline To Point Of Weld	D Butt Dia.	E End Of Spline To Brg. Shoulder	F Shoulder Dia.	G Length Of Shoulder	Part Number
1.375-31/32	1.378	2.750 X .065	3.375	8.812	2.625	7.469	1.719	1.125	N3-53-1181-2
1.375-31/32	1.380	1.620 X .205	3.375	9.000	1.219	7.469	1.630	***	N3-53-1181-5
1.375-16	1.378	2.500 X .083	4.969	8.094	2.344	6.750	1.719	1.125	N3-53-1351
1.375-16	1.378	3.000 X .083	4.969	8.094	2.844	6.750	1.719	1.125	N3-53-1361
1.375-16	1.378	3.000 X .083	4.438	7.031	2.844	5.969	1.688	0.812	N3-53-1371
1.375-16	1.355	3.000 x .083	4.438	7.031	2.844	5.590	1.772	1.190	N3-53-1372
1.562-16	1.575	3.500 X .083	5.938	8.531	3.344	7.469	1.938	0.812	N3-53-451
1.750-16	1.772	3.500 X .095	5.938	8.562	3.312	7.469	2.188	0.812	N4-53-61

STUB SHAFT

STUB SHAFT

MID-SHIP - CAP SCREW & SHAFT NUT TYPE

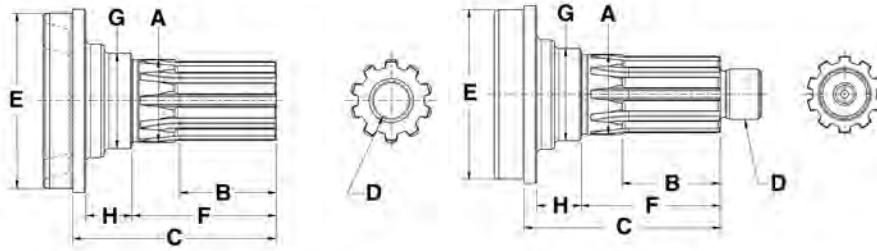

Spline/Number Teeth	A Bearing Dia.	Tubing Dia. And Wall	B Length Of Spline	C End Of Spline To Point Of Weld	D Thread Size	E Butt Dia.	F End Of Spline To Brg. Shoulder	G Shoulder Dia.	H Length Of Shoulder	Driveshaft Nut	Part Number
1.375-10	1.378	2.500 X .083	1.750	3.750	1.000-20-M UNF	2.344	2.688	1.688	0.812	***	N2-53-1191
1.375-10	1.378	3.000 X .083	1.969	3.969	0.50-20-F UNF	2.844	2.922	2.062	0.812	***	N3-53-191
1.375-10	1.378	3.000 X .083	1.688	4.000	1.000-20-M UNEF	2.844	2.656	1.719	1.125	***	N3-54-611
1.500-10	1.575	3.500 X .083	1.812	3.875	0.750-16-F UNF	3.344	2.750	1.812	0.875	***	N3-53-1081
1.500-10	1.575	3.000 X .083	1.938	3.875	1.000-20-M UNEF	2.844	2.750	1.812	0.875	***	N3-53-1781
1.500-10	1.575	3.500 X .083	1.938	3.875	1.000-20-M UNEF	3.344	2.750	1.812	0.875	***	N3-53-1791
1.500-10	1.575	3.500 X .083	1.875	4.031	0.750-16-F UNF	3.344	2.969	1.938	0.812	***	N3-53-431
1.500-10	1.575	3.500 X .095	1.875	4.031	0.750-16-F UNF	3.312	2.969	1.938	0.812	***	N4-53-71
1.750-10	1.772	3.500 X .134	2.094	4.344	1.250-18-M UNEF	3.250	3.250	2.188	0.812	***	N5-53-141
1.750-10	1.772	4.000 X .134	2.281	4.344	1.250-18-M UNEF	3.734	3.250	2.188	0.812	***	N5-53-191
1.750-34	1.772	4.000 X .134	2.156	4.219	1.250-18-M UNEF	3.750	3.125	2.188	0.812	***	N5-53-271
1.950-38	1.968	4.000 X .134	2.844	5.156	1.250-18-M UNEF	3.750	4.000	2.438	0.812	***	N6-53-411
1.953-10	1.968	4.000 X .134	2.875	5.156	1.250-18-M UNEF	3.750	4.000	2.438	0.812	***	N6-53-201
1.953-10	1.968	4.000 X .134	2.875	5.562	1.250-18-M UNEF	3.750	4.000	2.438	0.812	***	N6-53-201-1
1.953-10	1.968	4.000 X .134	2.875	5.156	1.250-18-M UNEF	4.250	4.000	2.438	0.812	***	N6-53-241
2.345-16	2.362	4.000 X .134	2.625	5.312	1.250-18-M UNEF	3.750	4.000	2.875	0.812	***	N6-53-311
2.345-16	2.362	4.500 X .259	2.750	5.438	1.250-18-M UNEF	4.000	4.000	2.875	0.812	***	N6.5-53-51
2.345-16	2.362	4.500 X .134	2.625	5.312	1.250-18-M UNEF	4.250	4.000	2.875	0.812	***	N6.5-53-91
2.350-46	2.362	5.196 X .236	2.719	5.312	1.250-18-M UNEF	4.750	4.000	2.875	0.812	N20-74-91	N250-53-11
2.350-46	2.362	4.095 X .180	2.719	5.312	1.250-18-M UNEF	3.750	4.000	2.875	0.812	***	N6.5-53-21
2.350-46	2.362	4.590 X .180	2.719	5.312	1.250-18-M UNEF	4.250	4.000	2.875	0.812	***	N6.5-53-171
2.350-46	2.362	4.500 X .259	2.719	5.312	1.250-18-M UNEF	4.000	4.000	2.875	0.812	***	N6.5-53-181

STUB SHAFT

SLIP STUB SHAFT

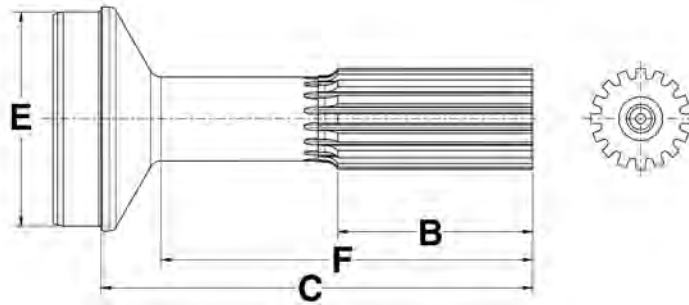

STUB SHAFT

Spline/Number Teeth	Tubing Dia. And Wall	B Length Of Spline	C End Of Spline To Weld	E Butt Dia.	F End Of Spline To Radius	Part Number
1.375-16	2.000 X .083	2.250	5.188	1.844	4.625	N2-40-1031
1.375-16	3.000 X .065	2.250	6.438	2.875	5.625	N2-40-1221
1.375-16	2.750 X .065	2.250	6.438	2.625	5.625	N2-40-1221-1
1.375-16	3.500 X .065	2.250	6.562	3.375	5.562	N2-40-1231
1.375-16	2.500 X .065	2.250	4.030	2.378	***	N2-40-1251
1.375-16	2.500 X .065	2.250	6.844	2.375	6.125	N2-40-1291
1.375-16	***	2.500	24-OAL	1.250	***	N2-40-138-2
1.375-16	3.000 X .083	2.250	6.438	2.844	5.625	N2-40-1521
1.375-16	3.500 X .083	2.250	6.625	3.344	5.625	N2-40-1531
1.375-16	2.000 X .120	2.250	6.188	1.766	5.625	N2-40-1701
1.375-16	2.000 X .120	2.250	6.688	1.766	6.125	N2-40-1701-1
1.375-16	2.000 X .120	6.250	7.750	1.766	7.250	N2-40-1701-2
1.375-16	2.500 X .083	2.250	6.344	2.344	5.625	N2-40-1711
1.375-16	2.500 X .095	2.250	6.344	2.312	5.625	N2-40-1712
1.250-16	2.000 X .083	2.000	6.000	1.844	5.406	N2-40-1741
1.250-16	1.250 X .120	2.000	6.125	1.031	5.375	N2-40-1771
1.375-16	2.500 X .065	2.250	6.344	2.375	5.625	N2-40-1811
1.375-16	2.000 X .083	2.250	6.688	1.844	6.125	N2-40-1841-1
1.375-16	2.500 X .083	2.250	7.531	2.344	6.812	N2-40-1851
1.375-16	3.000 X .083	6.781	6.641	2.844	7.828	N2-40-1871
1.375-16	2.500 X .095	2.250	7.531	2.312	6.812	N2-40-1951
1.375-16	3.000 X .065	2.250	7.625	2.880	6.812	N2-40-2051
1.375-16	3.500 X .083	6.969	8.969	3.344	7.969	N2-40-2091
1.250-16	2.500 X .065	2.000	6.125	2.375	5.406	N2-40-2211
1.375-16	3.000 X .083	2.250	7.625	2.844	6.812	N2-40-2231
1.250-16	2.500 X .065	2.500	7.562	2.375	6.844	N2-40-2301

STUB SHAFT

SLIP STUB SHAFT (Cont'd)

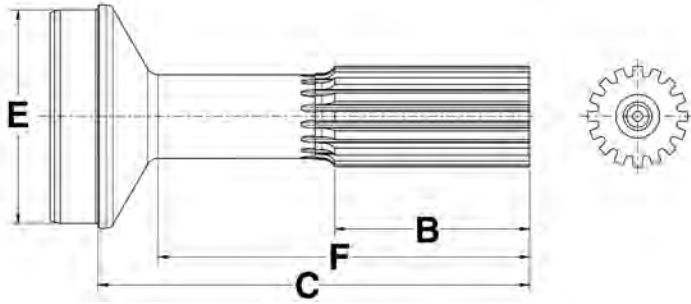

Spline/Number Teeth	Tubing Dia. And Wall	B Length Of Spline	C End Of Spline To Weld	E Butt Dia.	F End Of Spline To Radius	Part Number
1.250-16	2.000 X .120	2.000	6.000	1.766	5.406	N2-40-2381
1.375-16	2.500 X .095	3.375	8.125	2.312	7.250	N2-40-2791-1
1.250-16	2.000 X .083	2.000	4.750	1.844	4.188	N2-40-971-2
1.375-15	2.750 x .095	2.500	6.340	2.568	***	N2-53-711-2
1.500-16	3.000 X .083	2.500	5.938	2.844	5.125	N3-40-1101
1.500-16	2.750 X .083	2.500	7.250	2.594	6.438	N3-40-1222
1.563-16	3.500 X .083	4.500	8.750	3.344	7.812	N3-40-1391
1.500-16	2.500 X .083	2.500	5.625	2.344	4.969	N3-40-1471
1.500-16	2.500 X .095	2.500	5.625	2.312	4.969	N3-40-1472
1.500-16	3.500 X .083	3.000	7.531	3.344	6.594	N3-40-1491
1.500-16	3.500 X .095	3.000	***	3.312	6.594	N3-40-1492
1.500-16	3.500 X .083	3.000	6.562	3.344	5.625	N3-40-1531
1.500-16	3.500 X .083	2.500	7.344	3.344	6.406	N3-40-1561
1.563-16	3.500 X .083	3.000	6.750	3.344	5.812	N3-40-1571
1.500-16	3.000 X .083	2.500	7.250	2.844	6.438	N3-40-1611
1.500-16	2.000 X .120	6.531	8.766	1.766	7.766	N3-40-2012
1.500-16	2.500 X .083	6.531	8.766	2.344	7.766	N3-40-2508
1.500-16	2.500 X .095	6.531	8.766	2.312	7.766	N3-40-2509
1.500-16	2.500 X .120	6.531	8.766	2.266	7.766	N3-40-2512
1.500-16	3.000 X .083	6.531	8.766	2.844	7.766	N3-40-3008
1.500-16	3.500 X .083	6.531	8.766	3.344	7.766	N3-40-3508
1.750-16	3.500 X .095	3.000	9.219	3.312	8.250	N4-40-721
1.750-16	3.500 X .095	3.000	6.781	3.312	5.812	N4-40-761
2.000-16	3.500 X .134	3.500	9.688	3.250	8.781	N5-40-1011
2.000-16	3.500 X .134	3.500	10.188	3.250	9.281	N5-40-1041
2.000-16	4.000 X .134	3.500	9.844	3.750	5.875	N5-40-1051
2.000-16	3.500 X .134	3.500	7.562	3.250	6.562	N5-40-1191

STUB SHAFT

SLIP STUB SHAFT (Cont'd)

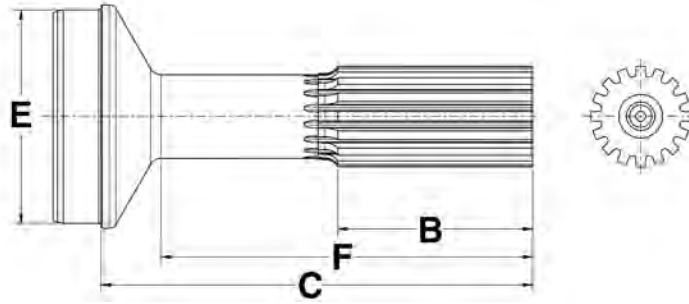

Spline/Number Teeth	Tubing Dia. And Wall	B Length Of Spline	C End Of Spline To Weld	E Butt Dia.	F End Of Spline To Radius	Part Number
2.000-16	3.500 X .095	3.500	9.562	3.312	8.656	N5-40-501
2.500-16	4.000 X .134	4.000	10.562	3.750	9.562	N6-40-521
2.500-16	4.000 X .134	4.000	9.250	3.750	8.250	N6-40-541
2.500-16	4.500 X .134	4.000	10.656	4.234	9.469	N6-40-621
2.500-16	4.500 X .134	4.000	9.500	4.234	8.312	N6-40-631
2.500-16	3.500 X .156	4.000	9.250	3.188	8.375	N6-40-741
3.000-16	4.500 X .134	4.500	11.250	4.234	10.031	N6.5-40-191
3.000-16	4.500 X .134	4.500	9.469	4.234	8.406	N6.5-40-201
3.000-16	4.500 X .259	4.500	11.531	4.000	10.250	N8-40-101
2.500-16	4.095 X .180	4.703	9.922	3.750	0.500	NPS40-16-61
3.000-16	4.590 X .180	4.703	10.125	4.250	***	NPS48-16-38

STUB SHAFT

STUB SHAFT

PTO STUB SHAFT

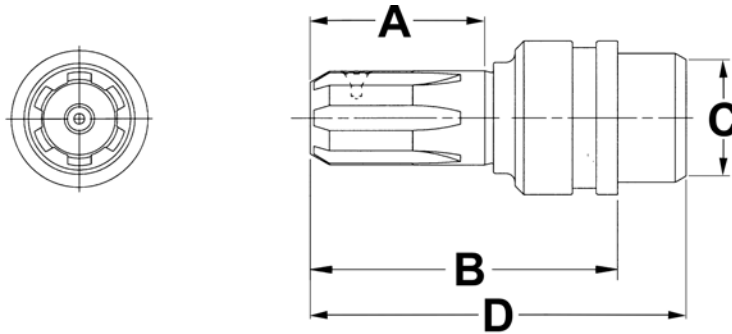

Spline/Number Teeth	Tubing Dia. And Wall	A Length Of Spline	B End Of Spline To Weld	C Butt Dia.	D End Of Spline To Radius	Part Number
***	2.000 X .083	***	5.130	1.840	***	10-0699
1.125-10	2.000 X .083	2.000	4.625	1.844	4.062	11-1753
1.125-10	***	2.000	2.500	1.060	2.250	51-0175
1.250-6B	2.000 X .083	1.750	2.750	1.842	3.000	53-2047
1.375-6B	2.250 X .120	1.750	2.750	2.000	3.000	53-2247

STUB SHAFT

Notes

STUB SHAFT



THE DRIVELINE EXPERTS

Yoke Shaft

SUB SECTION

Outside Lock-Up

Bearing Plate Construction

PlateLock Construction

Double Pivot Yoke Extended

SECTION

8



**Manufacturing Driveline Solutions®
in the USA Since 1921.**

NeapcoAftermarket.com

©Neapco LLC 2023

YOKE SHAFT

OUTSIDE LOCK-UP

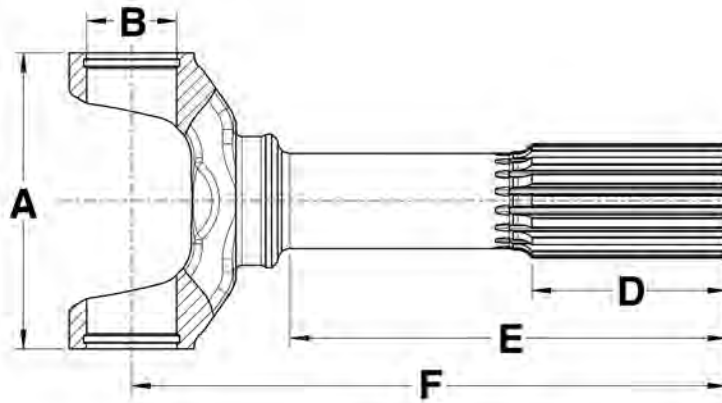

DL Series	Spline/Number Teeth	D Length Of Spline	E End Of Spline To Radius	F CL To End Of Spline	Joint Angle	Part Number
1310 Series A-3.469 B-1.063						
1310	1.375-16	2.250	3.562	5.312	16.0	N2-82-21
1310	1.250-16	1.875	3.422	5.125	20.0	N2-82-51
1350 Series A-3.875 B-1.188						
1350	1.500-16	2.500	4.688	6.812	20.0	N3-82-181
1350	1.500-16	2.000	3.016	5.188	20.0	N3-82-61
1410 Series A-4.438 B-1.188						
1410	1.500-16	2.000	3.250	4.969	16.0	N3-82-1191
1480 Series A-4.438 B-1.375						
1480	1.562-16	2.750	4.500	6.750	23.0	N3-82-1121
1550 Series A-5.250 B-1.375						
1550	1.750-16	1.438	2.500	4.750	8.0	N4-82-341

BEARING PLATE CONSTRUCTION

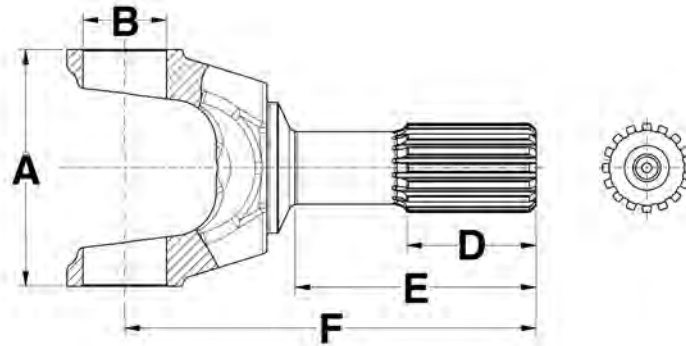

DL Series	Spline/Number Teeth	D Length Of Spline	E End Of Spline To Radius	F CL To End Of Spline	Joint Angle	Part Number
		20R Series		A-7.250 B-2.060		
20R	2.500-16	3.453	9.422	13.453	42.0	N20RYSM40-47
20R	2.500-16	3.453	10.734	15.203	42.0	N20RYSM40-51
		1610 Series		A-5.321 B-1.875		
1610	2.000-16	2.875	5.406	9.219	30.0	N5-82-01
		1710 Series		A-6.094 B-1.938		
1710	2.500-16	3.500	8.016	12.094	45.0	N6-82-1281
1710	2.500-16	3.500	9.016	13.094	45.0	N6-82-1281-1
1710	2.500-16	4.000	9.922	14.000	45.0	N6-82-1341-4
1710	2.500-16	4.000	10.953	15.031	45.0	N6-82-1341-7

YOKE SHAFT

PLATELOCK CONSTRUCTION

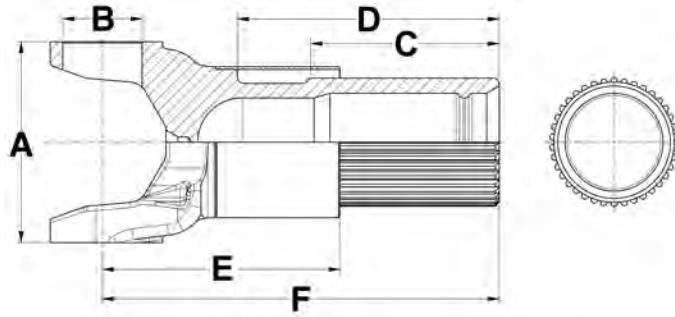

DL Series	Spline/Number Teeth	C Length Of Spline	D End Of Spline To Radius	E CL To End Of Tube	F CL To End Of Spline	Joint Angle	Part Number
NPL170/SPL170 Series				A-6.028	B-2.165		
NPL170/SPL170*	3.858-38	5.688	7.812	7.125	11.812	25.0	N170-82-21X
NPL170/SPL170*	3.465-34	6.984	9.125	7.828	13.828	45.0	N170-82-71X
NPL250/SPL250 Series				A-5.985	B-2.362		
NPL250/SPL250*	3.858-38	5.688	7.812	7.125	11.812	25.0	N250-82-21X

YOKE SHAFT

DOUBLE PIVOT YOKE EXTENDED

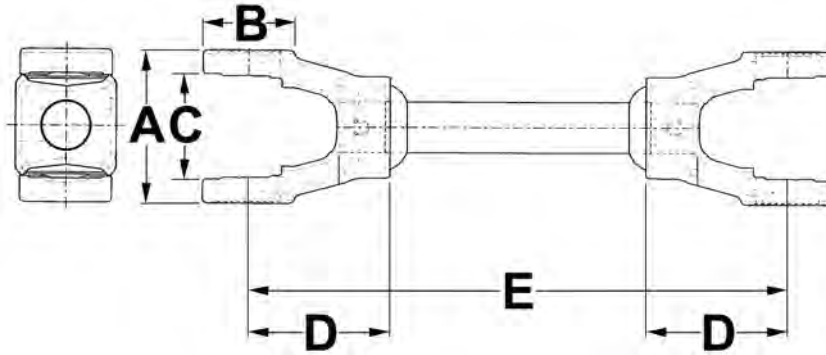

DL Series	Axle Dia.	D CL To CL Of Yokes	E CL UJ To CL UJ	Phasing	Part Number
1000 Series A-2.312 B-0.938 C-1.500					
1000	***	***	4.547	0°	NOE-12-2657-A
1000	***	***	8.547	0°	NOE-12-2658-A
1000	0.750	***	8.203	0°	NOE-12-5122-A
1000	0.938	***	7.500	0°	NOE-12-5139-A
1000	0.938	***	7.656	124°	NOE-12-5147-A
1000	***	1.688	***	0°	NOE-12-5244-A

YOKE SHAFT

YOKE SHAFT

Notes



THE DRIVELINE EXPERTS

Driveshaft & Double Cardan C.V.

SECTION

9

SUB SECTION

Double Cardan C.V. Ball Seat
Repair Kit

Double Cardan C.V. Head Assembly
PTO / AUX Shaft

Drive Shaft-Steel

UTV Drive Shafts

CV Axle Assembly

Drive Shaft Repair Kit

Driveshaft Kit

AND MUCH MORE!

**Manufacturing Driveline Solutions®
in the USA Since 1921.**

NeapcoAftermarket.com



DRIVESHAFT & DOUBLE CARDAN C.V.

DOUBLE CARDAN C.V. BALL SEAT REPAIR KIT

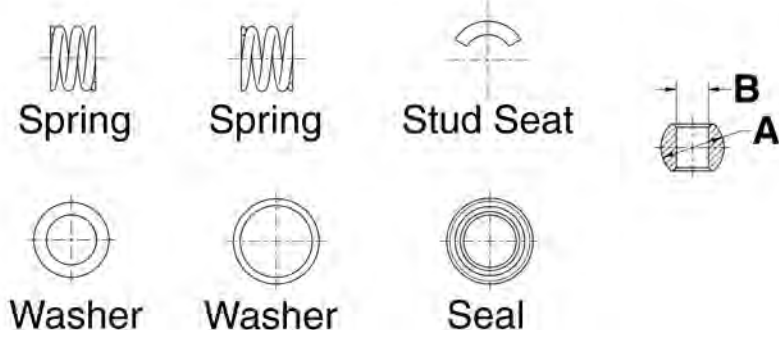

Manufacturer	A Ball Dia.	B Stud Bore Dia.	C Seal Outside Dia.	D Seal Height	Part Number
Saginaw	0.906	.625	***	***	2-9301
Saginaw	0.906	.453	1.250	0.172	2-9302

DOUBLE CARDAN C.V. BALL SEAT REPAIR KIT

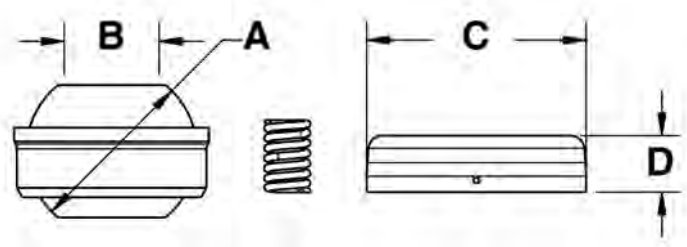

Manufacturer	A Ball Dia.	B Stud Bore Dia.	C Seal Outside Dia.	D Seal Height	Part Number
Spicer	1.125	.500	1.453	0.375	7-0081
Spicer	1.125	.500	1.344	0.156	7-0081NG
Toyota	1.344	.469	1.422	***	7-0407
Toyota	1.453	.516	1.516	***	7-0409

DRIVESHAFT & DOUBLE CARDAN C.V.

DOUBLE CARDAN C.V. HEAD ASSEMBLY

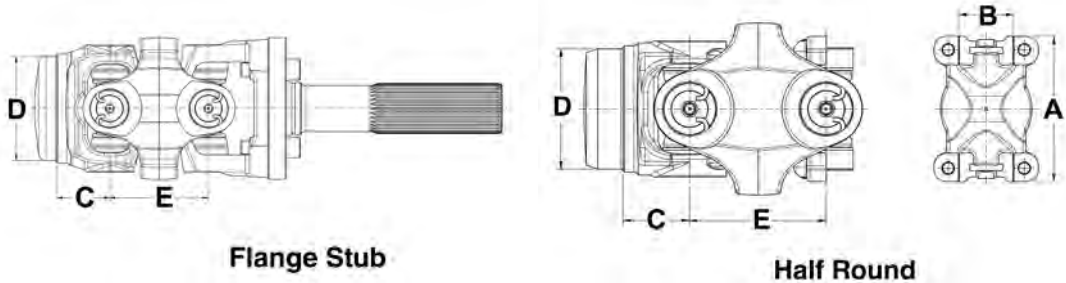

DL Series	DC Head Style	Tubing Dia. And Wall	Overall Length	C CL To Point Of Weld	D Butt Dia.	E CL To CL Of Center Yoke	E CL To CL Of H Yoke	E CL UJ To CL UJ	Pilot Dia.	Bolt Circle	Bolt Hole Spacing Height	Bolt Hole Spacing Width	Hole/ Thread Size	Joint Angle	Part Number
1310 Series										A-3.469 B-1.063					
1310	Flange	2.000 x 0.120	5.75	1.438	1.770	***	2.688	***	2.000	3.500	***	***	0.488	26.0	N913877
1310	Flange	2.000 x 0.120	5.75	1.438	1.770	***	2.688	***	2.000	3.500	***	***	0.488	26.0	N913877G
1310	Flange	2.500 x .083	5.75	1.438	2.344	***	2.688	***	2.000	3.500	***	***	0.488	26.0	N919279
1310	Flange	2.500 x .083	5.75	1.438	2.344	***	2.688	***	2.000	3.500	***	***	0.488	26.0	N919279G
1310	Flange Stub	3.000 x .083	12.12	1.438	2.842	***	2.688	***	2.000	3.000	***	***	3/8-24 UNF	26.0	N913600
1310	Flange Stub	2.000 x 0.120	12.12	1.438	1.770	***	2.688	***	2.000	3.000	***	***	3/8-24 UNF	26.0	N913601
1310	Flange Stub	2.000 x 0.120	12.12	1.438	1.770	***	2.688	***	2.000	3.000	***	***	3/8-24 UNF	26.0	N913601G
1310	Half Round	2.500 x .083	4.12	1.438	2.342	***	2.688	***	***	***	2.34	1.50	5/16-24 UNF	26.0	N912747
1310	Half Round	2.500 x .083	4.12	1.438	2.342	***	2.688	***	***	***	2.34	1.50	5/16-24 UNF	26.0	N912747G
1310	Half Round	2.000 x 0.120	4.12	1.438	1.770	***	2.688	***	***	***	2.34	1.50	5/16-24 UNF	26.0	N912777
1310	Half Round	2.000 x 0.120	4.12	1.438	1.770	***	2.688	***	***	***	2.34	1.50	5/16-24 UNF	26.0	N912777G
1310	Half Round	3.000 x .083	4.12	1.438	2.842	***	2.688	***	***	***	2.34	1.50	5/16-24 UNF	26.0	N912937
1310	Half Round	3.000 x .083	4.12	1.438	2.842	***	2.688	***	***	***	2.34	1.50	5/16-24 UNF	26.0	N912937G

DRIVESHAFT & D.C

DRIVESHAFT & DOUBLE CARDAN C.V.

DOUBLE CARDAN C.V. HEAD ASSEMBLY (Cont'd)

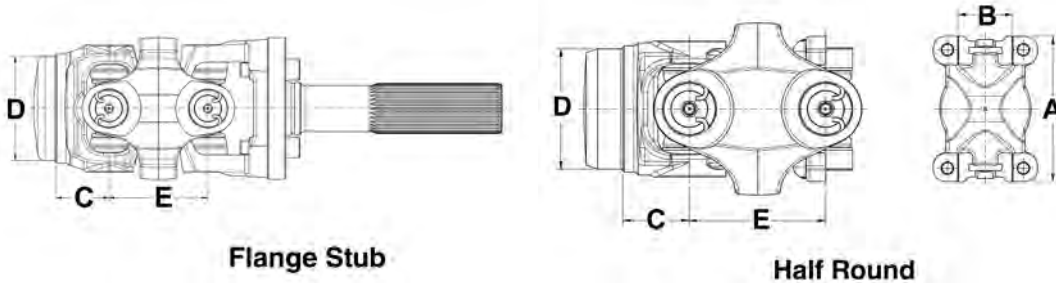

DL Series	DC Head Style	Tubing Dia. And Wall	Overall Length	C CL To Point Of Weld	D Butt Dia.	E CL To CL Of Center Yoke	E CL To CL Of H Yoke	E CL UJ To CL UJ	Pilot Dia.	Bolt Circle	Bolt Hole Spacing Height	Bolt Hole Spacing Width	Hole/ Thread Size	Joint Angle	Part Number	
1330 Series		A-3.875 B-1.063														
1330	Half Round	2.000 x 0.120	4.12	1.375	1.772	***	2.750	***	***	***	2.88	1.50	5/16-24 UNF	18.0	N910810	
1330	Half Round	2.500 x .083	4.12	1.375	2.342	***	2.750	***	***	***	2.88	1.50	5/16-24 UNF	18.0	N910811	
1330	Half Round	2.500 x .083	4.12	1.375	2.342	***	2.750	***	***	***	2.88	1.50	5/16-24 UNF	18.0	N910811G	
1330	Half Round	3.000 x .065	4.19	1.438	2.880	***	2.750	***	***	***	2.88	1.50	5/16-24 UNF	18.0	N910812	
1350 Series		A-3.875 B-1.188														
1350	Flange	2.000 x 0.120	***	1.440	1.770	***	1.44	***	2.000	4.250	***	***	0.488	***	N921047G	
1350	Flange	2.000 x 0.120	5.94	1.440	1.770	2.880	***	2.875	2.000	4.250	***	***	M12X1.75	32.0	N921048G	
1350	Flange	2.000 x 0.120	5.94	1.438	1.770	***	2.875	***	3.125	4.250	***	***	0.469	32.0	N921049	
1350	Flange	2.000 x 0.120	5.94	1.438	1.770	***	2.875	***	3.125	4.250	***	***	0.469	32.0	N921049G	
1350	Flange	2.500 x 0.095	5.94	1.438	2.320	***	2.875	***	3.125	4.250	***	***	0.469	32.0	N921050	
1350	Flange	2.500 x 0.095	5.94	1.438	2.320	***	2.875	***	3.125	4.250	***	***	0.469	32.0	N921050G	
1350	Flange	2.750 x .083	5.97	1.469	2.592	***	2.875	***	2.000	4.250	***	***	M12X1.75	32.0	N921052	
1350	Flange	2.750 x .083	5.97	1.469	2.592	***	2.875	***	2.000	4.250	***	***	M12X1.75	32.0	N921052G	
1350	Flange	3.000 x .083	5.97	1.469	2.844	***	2.875	***	2.000	4.250	***	***	M12X1.75	32.0	N921053	
1350	Flange	3.000 x .083	5.97	1.469	2.844	***	2.875	***	2.000	4.250	***	***	M12X1.75	32.0	N921053G	

DRIVESHAFT & DOUBLE CARDAN C.V.

DOUBLE CARDAN C.V. HEAD ASSEMBLY (Cont'd)

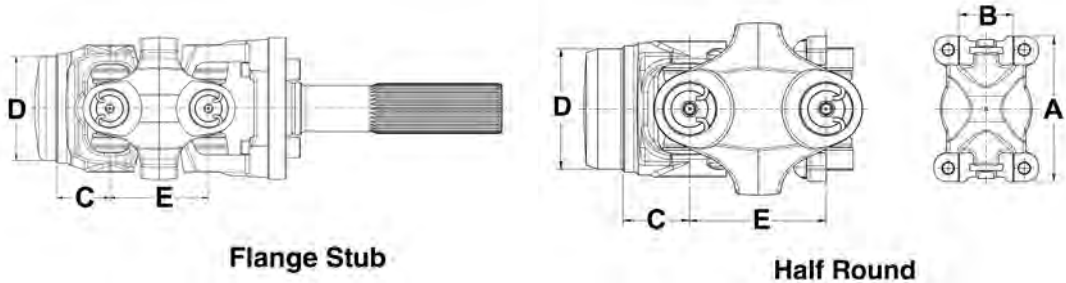

DL Series	DC Head Style	Tubing Dia. And Wall	Overall Length	C CL To Point Of Weld	D Butt Dia.	E CL To CL Of Center Yoke	E CL To CL Of H Yoke	E CL UJ To CL UJ	Pilot Dia.	Bolt Circle	Bolt Hole Spacing Height	Bolt Hole Spacing Width	Hole/ Thread Size	Joint Angle	Part Number
1350 Series									A-3.875 B-1.188						
1350	Flange	3.500 x .083	6.00	1.500	3.342	***	2.875	***	2.688	4.250	***	***	M12X1.75	32.0	N921054
1350	Flange	3.500 x .083	6.00	1.500	3.342	***	2.875	***	2.688	4.250	***	***	M12X1.75	32.0	N921054G
1350 Series									A-3.875 B-1.188						
1350	Flange	2.500 x 0.095	***	1.440	2.321	***	1.440	***	2.000	4.250	***	***	0.488	***	N921055G
1350	Flange	2.500 x 0.095	5.94	1.438	2.320	***	2.875	***	2.156	3.938	***	***	0.484	32.0	N921056
1350	Flange	2.500 x 0.095	5.94	1.438	2.320	***	2.875	***	2.156	3.938	***	***	0.484	32.0	N921056G
1350	Half Round	2.000 x 0.120	***	4.310	1.770	***	2.875	***	***	***	2.75	1.63	5/16 - 24 UNF 2B	***	N921019G
1350	Half Round	2.500 x 0.095	***	4.310	2.320	***	2.875	***	***	***	2.75	1.63	5/16 - 24 UNF 2B	***	N921020G
1410 Series									A-4.438 B-1.188						
1410	Flange	2.500 x 0.120	7.32	2.094	2.260	***	3.484	***	3.125	4.250	***	***	0.469	22.0	N924141G
1410	Flange	2.500 x 0.120	7.32	2.094	2.260	***	3.484	***	3.125	4.250	***	***	0.469	30.0	N924141HAG
1410	Flange	2.750 x .083	7.72	2.484	2.591	***	3.484	***	2.688	4.250	***	***	0.500	30.0	N924142HAG
1410	Flange	2.500 x 0.120	7.32	2.094	2.260	***	3.484	***	2.688	4.250	***	***	0.500	30.0	N924143HAG

DRIVESHAFT & D.C

DRIVESHAFT & DOUBLE CARDAN C.V.

PTO / AUX SHAFT

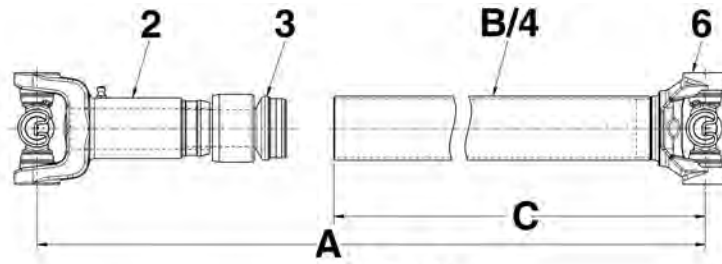

Type 1

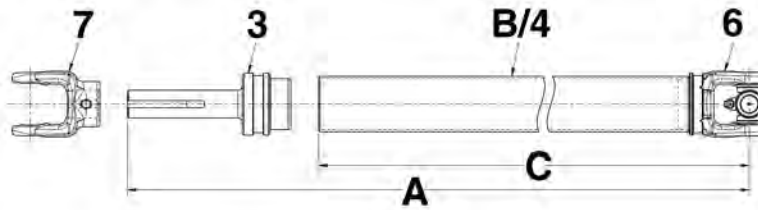

Type 2

DL Series	Driveshaft Style	Tubing Dia. And Wall	CL To CL Max. Extended Length	CL To CL Collapsed Length	Yoke/cv And Tube Length	Yoke Bore 1	Yoke Bore 2
1000 Series			A-2.312	B-0.938	C-1.500		
1000	Unwelded-1	2.000 X .083	65.125	63.125	56.906	***	***
1000	Unwelded-1	2.000 X .083	65.125	63.125	56.906	***	***
1000	Unwelded-2	2.000 X .083	65.031	65.031	60.250	***	***
1000	Welded-15	2.000 X .083	36.750	23.250	***	1.250	1.125
1000	Welded-15	2.000 X .083	54.000	34.000	***	1.250	1.125
1000	Welded-15	2.000 X .083	54.000	34.000	***	1.250	1.250
1000	Welded-15	2.000 X .083	67.000	47.000	***	1.250	1.125
1000	Welded-16	2.000 X .083	54.000	34.000	***	1.125	***
1310 Series			A-3.469	B-1.063			
1310	Unwelded-1	2.000 X .083	57.969	55.688	49.438	***	***
1310	Unwelded-3	1.250	28.438	26.125	25.062	***	***
1350 Series			A-3.875	B-1.188			
1350	Unwelded-1	2.500 X .083	63.078	61.078	54.188	***	***
1350	Unwelded-1	2.500 X .083	63.078	61.078	54.188	***	***
1350	Welded-13	3.000 X .083	37.812	35.812	***	***	***
1410 Series			A-4.438	B-1.188			
1410	Welded-13	3.500 X .083	25.750	22.250	***	***	***
1410	Welded-13	3.000 X .083	37.719	34.281	***	***	***
1410	Welded-13	3.000 X .083	49.750	46.250	***	***	***

DRIVESHAFT & DOUBLE CARDAN C.V.

PTO / AUX SHAFT

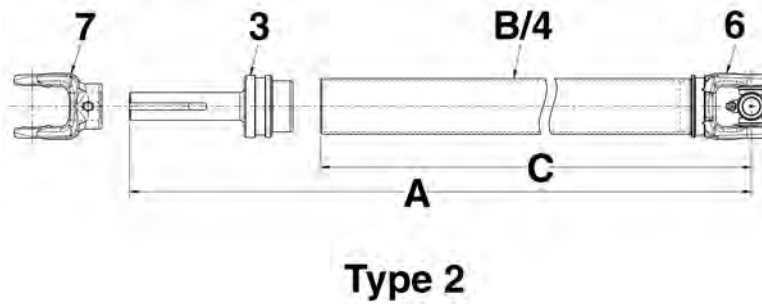
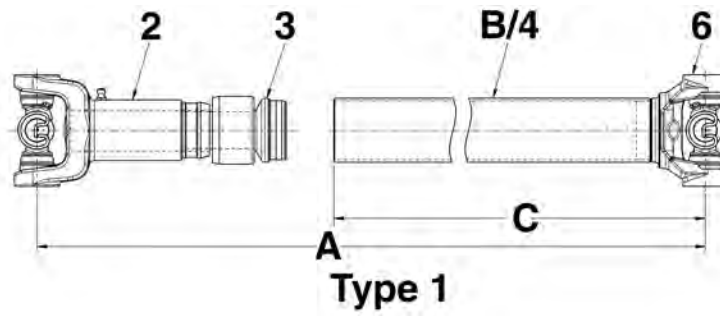

Lubrication Type	Bolt Circle	Bolt Hole Pattern	C Length Between Holes	D Length Between Holes	Part Numbers
1000 Series			A-2.312	B-0.938	C-1.500
***	***	***	***	***	N10270-SF
***	***	***	***	***	N10270-SFG
***	***	***	***	***	N10271-SF
***	***	***	***	***	UTS10-232398
***	***	***	***	***	UTS10-233498
***	***	***	***	***	UTS10-2334EH
***	***	***	***	***	UTS10-235298
***	***	***	***	***	UTS10-984099
1310 Series			A-3.469	B-1.063	
CROSS	***	***	***	***	N9553-SF
CROSS	***	***	***	***	N91382-SF
1350 Series			A-3.875	B-1.188	
CROSS	***	***	***	***	N7703-SF
END-LUBE	***	***	***	***	N7713-SF
***	3.750	Rectangle	2.41	2.873	N135-36-SLBP
1410 Series			A-4.438	B-1.188	
***	3.750	Rectangle	2.41	2.873	N141-24-SLBP
***	3.750	Rectangle	2.41	2.873	N141-36-SLBP
***	3.750	Rectangle	2.41	2.873	N141-48-SLBP

DRIVESHAFT & DOUBLE CARDAN C.V.

PTO / AUX SHAFT (Cont'd)

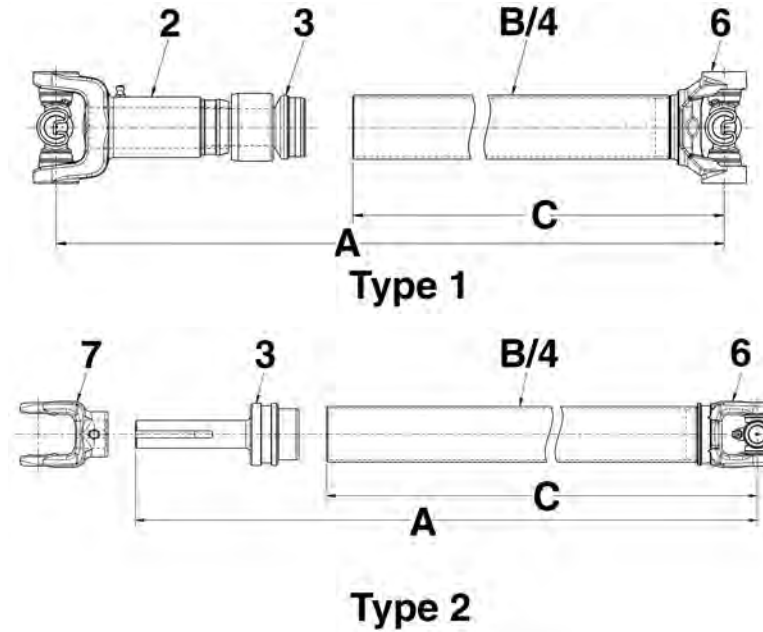

DL Series	Driveshaft Style	Tubing Dia. And Wall	CL To CL Max. Extended Length	CL To CL Collapsed Length	Yoke/cv And Tube Length	Yoke Bore 1	Yoke Bore 2
1480 Series				A-4.438	B-1.375		
1480*	Welded-13	3.500 X .083	25.250	22.750	***	***	***
1480*	Welded-13	3.000 X .083	36.875	35.250	***	***	***
1550 Series				A-5.250	B-1.375		
1550*	Welded-13	3.500 X .095	25.250	22.750	***	***	***
1550*	Welded-13	3.500 X .095	37.250	34.750	***	***	***
1550*	Welded-13	3.500 X .095	49.250	46.750	***	***	***
1610 Series				A-5.321	B-1.875		
1610*	Welded-13	3.500 X .134	50.000	46.000	***	***	***
1710 Series				A-6.094	B-1.938		
1710*	Welded-13	4.000 X .134	38.620	33.375	***	***	***
1710*	Welded-13	4.000 X .134	50.620	45.375	***	***	***
1810 Series				A-7.547	B-1.938		
1810*	Welded-13	4.500 X .134	37.688	34.312	***	***	***
1810*	Welded-13	4.500 X .134	49.969	39.562	***	***	***
B&P2 Series				A-2.413	B-0.937		
B&P2*	Welded-17	***	***	43.578	***	1.375 X 6 SPL	***
B&P2*	Welded-17	***	***	55.391	***	1.375 X 6 SPL	***
B&P2*	Welded-17	***	***	45.750	***	1.375 X 6 SPL	***

* SPL - Spicer® Life Series driveshafts is a registered trademark of Dana Limited

DRIVESHAFT & DOUBLE CARDAN C.V.

PTO / AUX SHAFT (Cont'd)

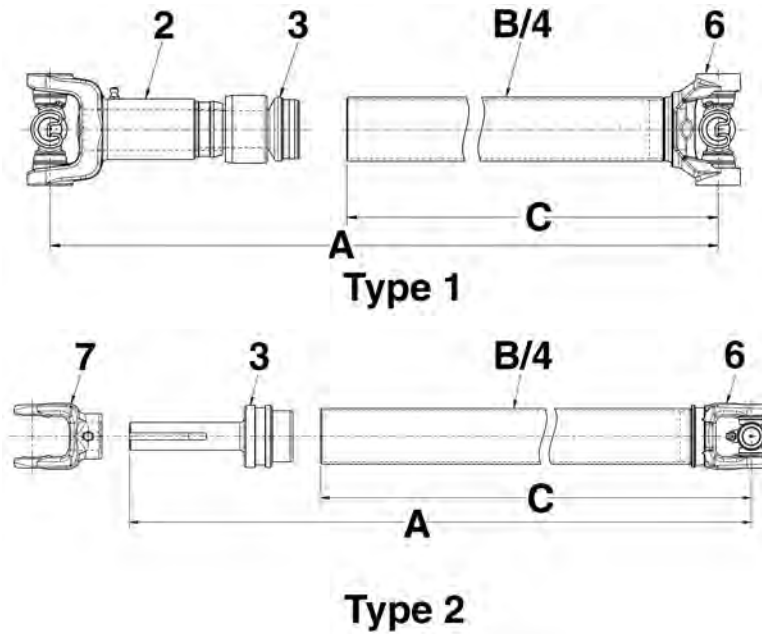

Lubrication Type	Bolt Circle	Bolt Hole Pattern	C Length Between Holes	D Length Between Holes	Part Numbers
1480 Series			A-4.438	B-1.375	
***	4.750	Rectangle	3.053	3.639	N148-24-SLBP
***	4.750	Rectangle	3.053	3.639	N148-36-SLBP
1550 Series			A-5.250	B-1.375	
***	4.750	Rectangle	3.053	3.639	N155-24-SLBP
***	4.750	Rectangle	3.053	3.639	N155-36-SLBP
***	4.750	Rectangle	3.053	3.639	N155-48-SLBP
1610 Series			A-5.321	B-1.875	
***	6.125	Round	***	***	N161-48-SLBP
1710 Series			A-6.094	B-1.938	
***	7.250	Round	***	***	N171-36-SLBP
***	7.250	Round	***	***	N171-48-SLBP
1810 Series			A-7.547	B-1.938	
***	7.250	Round	***	***	N181-36-SLBP
***	7.250	Round	***	***	N181-48-SLBP
B&P2 Series			A-2.413	B-0.937	
***	***	***	***	***	8-0100
***	***	***	***	***	8-0101
***	***	***	***	***	8-0102

DRIVESHAFT & D.C

* SPL - Spicer® Life Series driveshafts is a registered trademark of Dana Limited

DRIVESHAFT & DOUBLE CARDAN C.V.

PTO / AUX SHAFT (Cont'd)

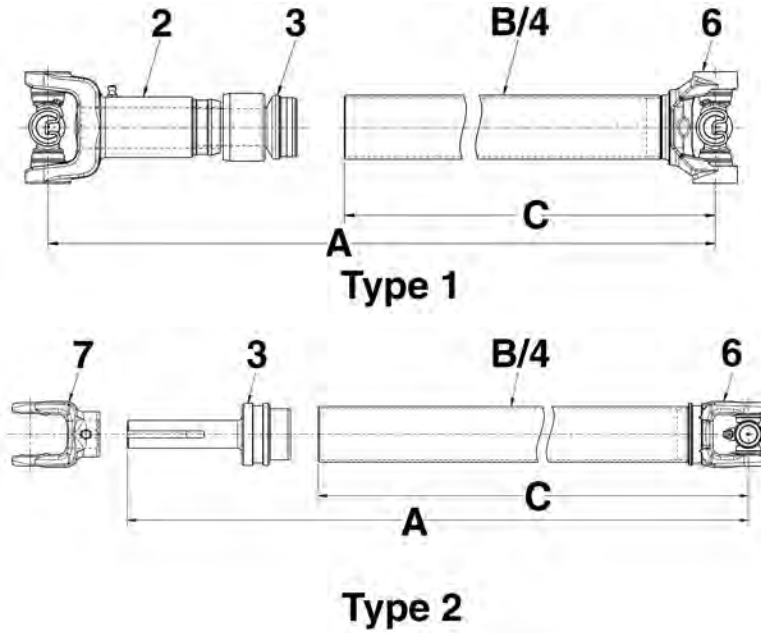

DL Series	Driveshaft Style	Tubing Dia. And Wall	CL To CL Max. Extended Length	CL To CL Collapsed Length	Yoke/cv And Tube Length	Yoke Bore 1	Yoke Bore 2
B&P3 Series			A-2.756	B-1.063			
B&P3*	Welded-17	***	***	57.562	***	1.375 X 6 SPL	***
B&P4 Series			A-2.937	B-1.063			
B&P4*	Welded-17	***	***	46.016	***	1.375 X 6 SPL	***
B&P4*	Welded-17	***	***	57.828	***	1.375 X 6 SPL	***
B&P5 Series			A-3.15	B-1.189			
B&P5*	Welded-17	***	***	44.172	***	1.375 X 6 SPL	***
B&P5*	Welded-17	***	***	55.984	***	1.375 X 6 SPL	***
B&P6 Series			A-3.622	B-1.189			
B&P6*	Welded-17	***	***	44.562	***	1.375 X 6 SPL	***
B&P6*	Welded-17	***	***	56.375	***	1.375 X 6 SPL	***
B&P7 Series			A-3.701	B-1.378			
B&P7*	Welded-17	***	***	44.562	***	1.375 X 6 SPL	***
B&P7*	Welded-17	***	***	56.375	***	1.375 X 6 SPL	***
B&P8 Series			A-4.193	B-1.378			
B&P8*	Welded-17	***	***	42.719	***	1.375 X 6 SPL	***
B&P8*	Welded-17	***	***	54.531	***	1.375 X 6 SPL	***

* SPL - Spicer® Life Series driveshafts is a registered trademark of Dana Limited

DRIVESHAFT & DOUBLE CARDAN C.V.

PTO / AUX SHAFT (Cont'd)

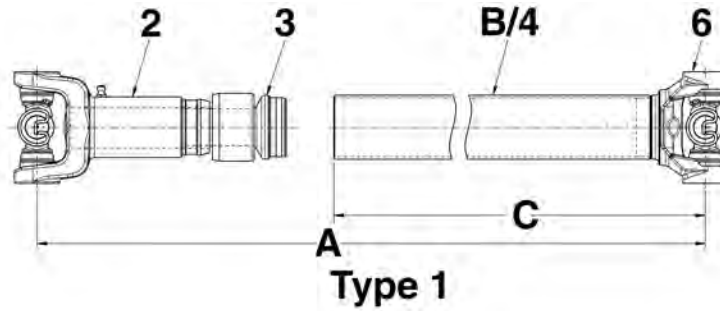

Type 1

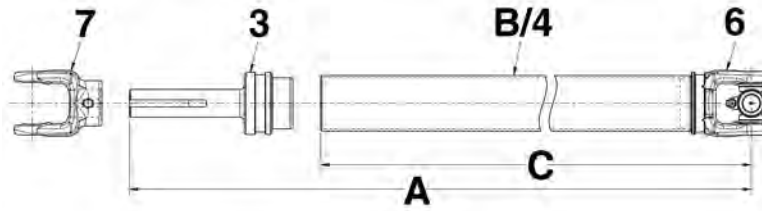

Type 2

Lubrication Type	Bolt Circle	Bolt Hole Pattern	C Length Between Holes	D Length Between Holes	Part Numbers
B&P3 Series			A-2.756	B-1.063	
***	***	***	***	***	8-0103
B&P4 Series			A-2.937	B-1.063	
***	***	***	***	***	8-0104
***	***	***	***	***	8-0105
B&P5 Series			A-3.15	B-1.189	
***	***	***	***	***	8-0106
***	***	***	***	***	8-0107
B&P6 Series			A-3.622	B-1.189	
***	***	***	***	***	8-0108
***	***	***	***	***	8-0109
B&P7 Series			A-3.701	B-1.378	
***	***	***	***	***	8-0110
***	***	***	***	***	8-0111
B&P8 Series			A-4.193	B-1.378	
***	***	***	***	***	8-0112
***	***	***	***	***	8-0113

DRIVESHAFT & D.C

* SPL - Spicer® Life Series driveshafts is a registered trademark of Dana Limited

DRIVESHAFT & DOUBLE CARDAN C.V.

PTO / AUX SHAFT (Cont'd)

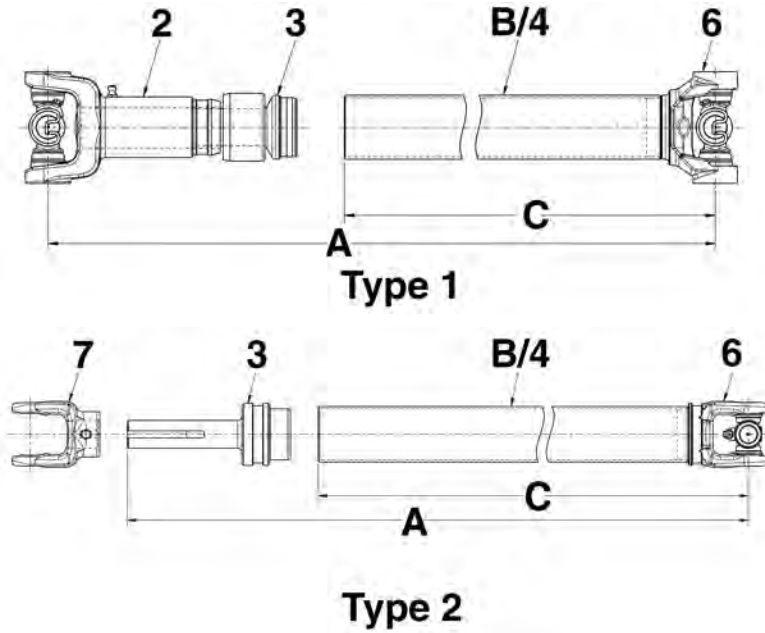

DL Series	Driveshaft Style	Tubing Dia. And Wall	CL To CL Max. Extended Length	CL To CL Collapsed Length	Yoke/cv And Tube Length	Yoke Bore 1	Yoke Bore 2
W2480							
W2480*	Welded-18	***	***	60.594	***	1.375 X 6 SPL	1.375 X 6 SPL
W2480*	Welded-18	***	***	60.594	***	1.375 X 21 SPL	1.375 X 6 SPL
W2480*	Welded-18	***	***	60.594	***	1.750 X 20 SPL	1.750 X 20 SPL
W2580							
W2580*	Welded-19	***	***	61.266	***	1.375 X 6 SPL	1.375 X 6 SPL
W2580*	Welded-19	***	***	61.266	***	1.375 X 21 SPL	1.375 X 6 SPL
W2580*	Welded-19	***	***	61.266	***	1.750 X 20 SPL	1.750 X 20 SPL

* SPL - Spicer® Life Series driveshafts is a registered trademark of Dana Limited

DRIVESHAFT & DOUBLE CARDAN C.V.

PTO / AUX SHAFT (Cont'd)

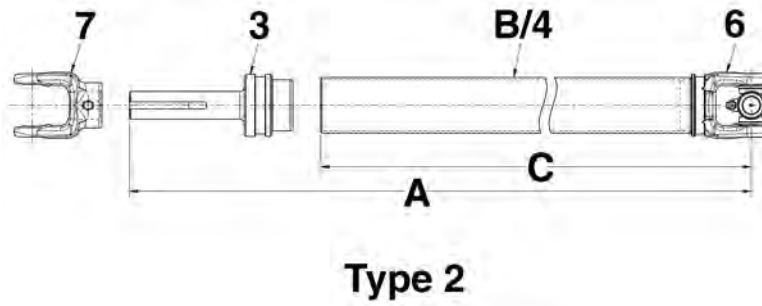
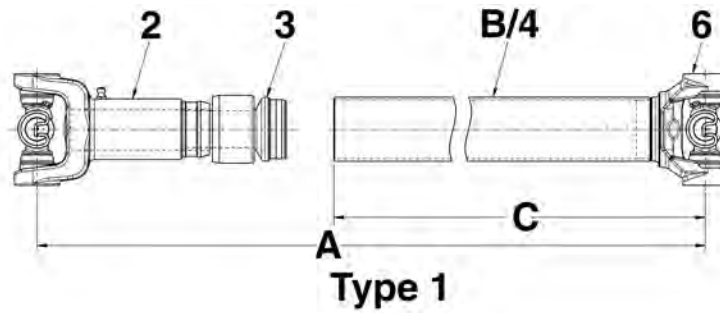

Lubrication Type	Bolt Circle	Bolt Hole Pattern	C Length Between Holes	D Length Between Holes	Part Numbers
W2480					
***	***	***	***	***	8-0200
***	***	***	***	***	8-0201
***	***	***	***	***	8-0202
W2580					
***	***	***	***	***	8-0203
***	***	***	***	***	8-0204
***	***	***	***	***	8-0205

DRIVESHAFT & DOUBLE CARDAN C.V.

DRIVE SHAFT - DIAGRAMS

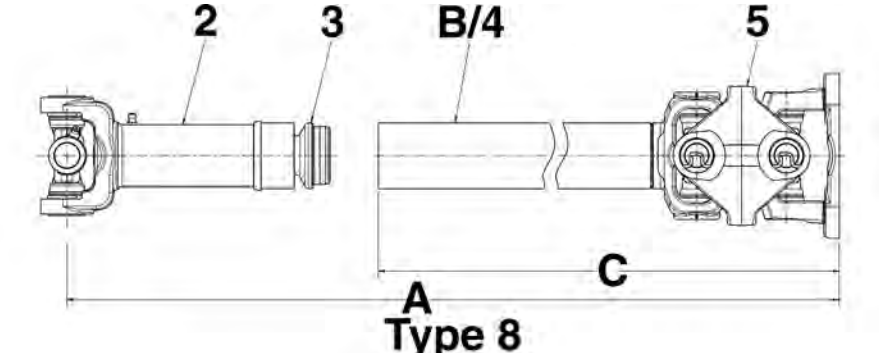
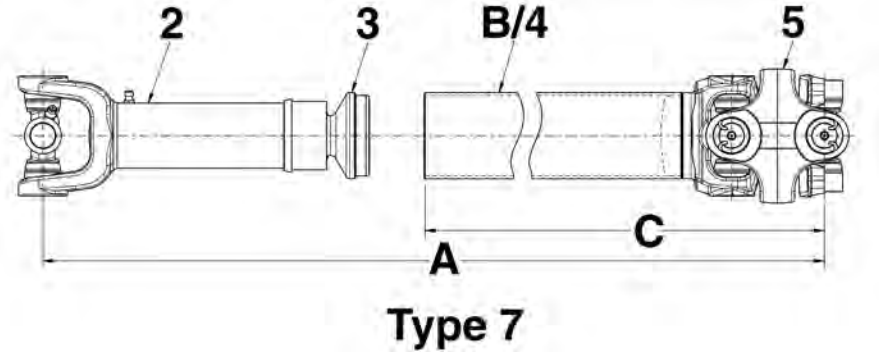
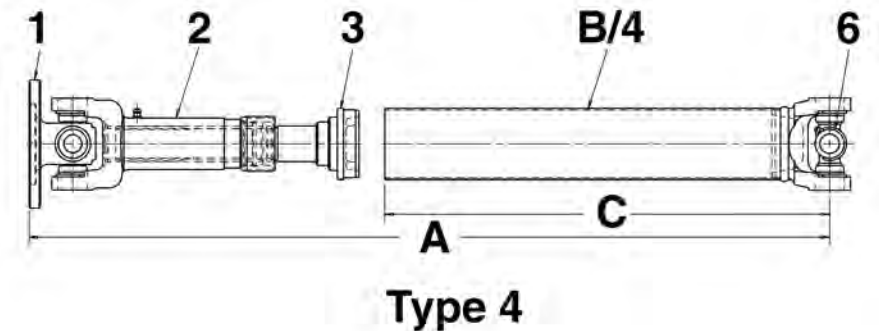

DRIVESHAFT & DOUBLE CARDAN C.V.

DRIVE SHAFT - DIAGRAMS

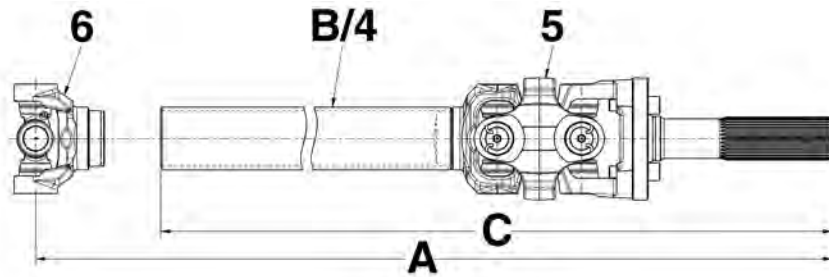

Type 9

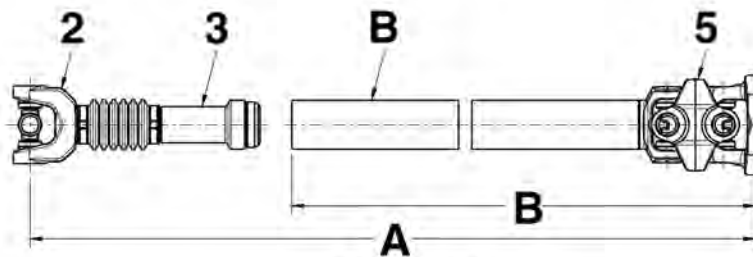

Type 14

DRIVESHAFT & DOUBLE CARDAN C.V.

DRIVE SHAFT - STEEL

DL Series	Driveshaft Style	Tubing Dia. And Wall	CL To CL Max. Extended Length	CL To CL Col-lapsed Length	Yoke/cv And Tube Length	CL To Point Of Weld	Joint Angle
1000 Series A-2.312 B-0.938 C-1.500							
1000	Unwelded	1.250 x .095	43.84 0	42.090	36.00	***	***
1200 Series A-2.562 B-1.063 C-1.812							
1200	Type 1	2.250	25.630	11.380	***	1.920	***
1210 Series A-2.562 B-1.063 C-1.812							
1210	Welded-10	2.500 X .065	34.000 IN	30.000 IN	***	***	***
1310 Series A-3.469 B-1.063							
1310	Type 1	2.000 X .083	57.640	55.640	49.390	1.690	***
1310	Type 1	2.000 X .084	60.640	58.390	49.390	1.690	***
1310	Type 7	2.500 X .083	53.070	49.240	40.180	***	***
1310	Type 7	2.500 X .083	53.070	49.240	40.180	***	***
1310	Type 7	2.000 X .120	50.880	49.790	40.070	***	***
1310	Type 7	2.000 X .120	50.880	49.790	40.070	***	***
1310 / 1350 Series							
1310 / 1350	Type 8	2.500 X .120	52.700	49.610	41.890	1.390	***
1330 Series A-3.875 B-1.063							
1330	Type 7	2.500 X .083	52.910	48.720	40.130	***	***
1330/1350 Series							
1330/1350	Type 8	2.500 X .095	54.060	51.180	41.940	***	***
1330/1350	Type 8	2.500 X .095	54.060	51.180	41.940	5.940	***
1330/1350	Type 8	2.500 X .095	52.020	49.350	41.940	***	***
1350 Series A-3.875 B-1.188							
1350	Type 1	2.500 X .083	63.080	61.080	55.75	54.190	***
1350	Type 14	2.500 X .095	53.050	51.550	42.040	5.940	32.0
1350	Type 8	2.000 X .120	53.500	50.220	41.940	1.440	***
1350	Type 8	2.500 X .095	53.950	51.330	41.940	***	***
1350	Type 8	2.500 X .095	53.950	51.330	41.940	5.940	***
1350	Type 8	2.750 X .083	53.930	50.490	41.970	***	***
1350	Type 8	2.750 X .083	53.930	50.490	41.970	***	***
1350	Type 8	3.500 X .083	71.850XV	68.600	60.000	***	***
1410 Series A-4.438 B-1.188							
1410	Type 14	2.500 X .120	53.770	52.270	43.320	***	22.0
1410/1350 Series							
1410/1350	Type 8	3.500 X .083	72.390	68.950	60.000	***	***

DRIVESHAFT & DOUBLE CARDAN C.V.

DRIVE SHAFT - STEEL

Yoke Bore 1	Yoke Bore 2	Bolt Circle	Bolt Hole Pattern	C Length Between Holes	D Length Between Holes	Part Number
1000 Series A-2.312 B-0.938 C-1.500						
1.250	1.060	***	***	***	***	63-0642
1200 Series A-2.562 B-1.063 C-1.812						
***	***	***	***	***	***	12-3356
1210 Series A-2.562 B-1.063 C-1.812						
***	***	***	***	***	***	N914156-1324W
1310 Series A-3.469 B-1.063						
3.219	3.219	***	***	***	***	N9553-SFG
3.219	3.219	***	***	***	***	N9553-SF-LS
3.469	3.469	***	***	***	***	N909363-3600
3.469	3.469	***	***	***	***	N909363G-3600
3.469	3.469	***	***	***	***	N909365-3600
3.469	3.469	***	***	***	***	N909365G-3600
1310 / 1350 Series						
3.875	3.000	4.250	Square	3.005	3.005	S91397-3600
1330 Series A-3.875 B-1.063						
3.875	3.875	***	***	***	***	N911818-3600
1330/1350 Series						
3.875	3.875	4.250	Square	3.005	3.005	N921050-3600
3.875	3.875	4.250	Square	3.005	3.005	N921050G-3600
3.875	3.875	3.938	Square	2.785	2.785	N921056X-3600
1350 Series A-3.875 B-1.188						
***	***	***	***	***	***	N7723-SFG
3.875	3.875	4.250	Square	3.005	3.005	N921050G-3610
3.875	3.875	4.250	Square	3.005	3.005	N921048G-3600
3.875	3.875	4.250	Square	3.005	3.005	N921050-3607
3.875	3.875	4.250	Square	3.005	3.005	N921050G-3607
3.875	3.875	4.250	Square	3.005	3.005	N921052-3600
3.875	3.875	4.250	Square	3.005	3.005	N921052G-3600
3.875	3.875	4.250	Square	3.005	3.005	N921054-5400
1410 Series A-4.438 B-1.188						
4.438	4.438	4.250	Square	3.005	3.005	N924141G-3613
1410/1350 Series						
4.438	4.438	4.250	Square	3.005	3.005	N921054-5401

DRIVESHAFT & DOUBLE CARDAN C.V.

DRIVE SHAFT - STEEL

DL Series	Driveshaft Style	Tubing Dia. And Wall	CL To CL Max. Extended Length	CL To CL Col-lapsed Length	Yoke/cv And Tube Length	CL To Point Of Weld	Joint Angle
3R Series A-3.563 B-1.125 C-2.563							
3R	Type 4	2.750 X .065	53.060	49.940	37.750	1.750	***
3R	Type 9	2.000 X .120	49.830	***	n/a	***	***
3R/1350 Series							
3R/1350	Type 8	2.500 X .095	53.940	51.440	41.940	***	***
3R/1350	Type 8	2.500 X .095	53.940	51.440	41.940	5.940	***
7260 / 1350 Series							
7260 / 1350	Type 8	2.500 X .120	52.700	49.610	41.890	1.390	***
7290 / 1350 Series							
7290 / 1350	Type 8	2.500 X .120	52.390	49.450	41.890	1.390	***
L600 Series A-1.45 B-0.97							
L600	Type 1	1.50	6.880	6.880	***	2.00	***

DRIVESHAFT & DOUBLE CARDAN C.V.

DRIVE SHAFT - STEEL

Yoke Bore 1	Yoke Bore 2	Bolt Circle	Bolt Hole Pattern	C Length Between Holes	D Length Between Holes	Part Number
3R Series A-3.563 B-1.125 C-2.563						
3.563	3.563	***	***	***	***	S91397-3603
3.563	3.563	***	***	***	***	N131138-3600
3R/1350 Series						
3.563	3.563	4.250	Square	3.005	3.005	N921050-3603
3.563	3.563	4.250	Square	3.005	3.005	N921050G-3603
7260 / 1350 Series						
3.875	3.000	4.250	Square	3.005	3.005	S91397-3601
7290 / 1350 Series						
3.875	3.563	4.250	Square	3.005	3.005	S91397-3602
L600 Series A-1.45 B-0.97						
***	***	***	***	***	***	16-8687

DRIVESHAFT & DOUBLE CARDAN C.V.

UTV DriveShafts

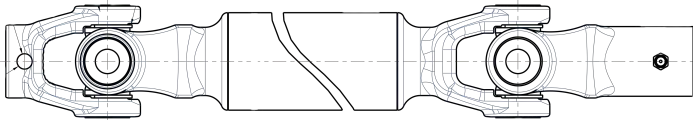

Tube Size	Overall Length	Spline Tooth Count A	Spline Tooth Count B	Part Number
51.0	1628.0	22	22	NOE-10-2951-A
32.0	627.0	22	21/22	NOE-10-2993-A
32.0	1093.0	22	22	NOE-10-2994-A
32.0	1016.0	22	21/22	NOE-10-2996-A
32.0	1361.0	22	22	NOE-10-2997-A
32.0	625.0	22	21/22	NOE-10-3271-A
32.0	1297.0	22	22	NOE-10-3272-A
32.0	621.0	22	21/22	NOE-10-3350-A
32.0	1123.0	22	22	NOE-10-3441-A
38.0	1175.0	21/22	4 bolt	NOE-10-3443-A
41.0	762.0	22	22	NOE-10-3445-A
41.0	1460.0	22	22	NOE-10-3447-A

DRIVESHAFT & DOUBLE CARDAN C.V.

CV Axle Assembly

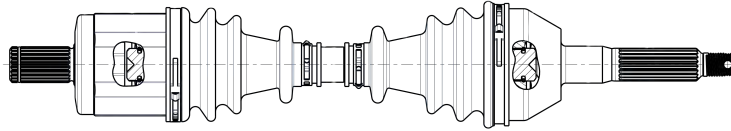

Compressed Length	Extended Length	Inboard Boot Number	Inboard Clamp 1 Number	Inboard Clamp 2 Number	Inboard Spine Length	Inboard Spine Tooth Count	Outboard Boot Number	Outboard Clamp 1 Number	Outboard Clamp 2 Number	Outboard Hub Dia.	Outboard Hub Length	Outboard Spine To Full Thread Length	Outboard Spine Tooth Count	Pin Dia.	Wheel Stud Length	Wheel Stud Thread	Part Number
306.8	347.4	9312	93-7478	93-5100	43.4	22 / 24-28	9300	93-5100	93-5000	25.0	117.6	57.2	20	0.08	19.8	5/8-18	NOE-89-7902-A
309.6	340.1	9312	93-7478	93-5100	43.4	22 / 24-28	9300	93-5100	93-5000	25.0	117.6	57.2	20	0.08	19.8	5/8-18	NOE-89-1474-A
326.9	372.9	9312	93-7478	93-5100	43.4	22 / 24-28	9300	93-5100	93-5000	***	79.2	62.1	20	0.08	17.0	5/8-18	NOE-89-8581-A
368.7	409.0	***	***	***	***	22	***	***	***	***	***	***	20	***	***	***	NOE-89-7901-A
378.6	419.2	9312	93-7478	93-5100	43.4	22 / 24-28	9300	93-5100	93-5000	25.0	117.6	57.2	20	0.08	19.8	5/8-18	NOE-89-7903-A
379.5	410.0	9312	93-7478	93-5100	43.4	22 / 24-28	9300	93-5100	93-5000	25.0	117.6	57.2	20	0.08	19.8	5/8-18	NOE-89-2473-A
391.7	422.2	9312	93-7478	93-5100	44.4	23 / 24-28	9300	93-5100	93-5000	25.0	117.6	57.2	21	0.08	19.8	5/8-19	NOE-89-1476-A
465.1	495.6	9312	93-7478	93-5100	43.4	22 / 24-28	9300	93-5100	93-5000	25.0	117.6	57.2	20	0.08	19.8	5/8-18	NOE-89-2936-A
554.0	594.0	***	***	***	***	36	***	***	***	***	***	***	26	***	***	***	NOE-89-2935-A
555.0	596.0	***	***	***	***	28	***	***	***	***	***	***	26	***	***	***	NOE-89-3275-A
557.0	597.0	***	***	***	***	36	***	***	***	***	***	***	26	***	***	***	NOE-89-2938-A
562.0	603.0	***	***	***	***	22	***	***	***	***	***	***	26	***	***	***	NOE-89-2873-A
572.0	613.0	***	***	***	***	27	***	***	***	***	***	***	26	***	***	***	NOE-89-2884-A
620.0	661.0	***	***	***	***	26	***	***	***	***	***	***	26	***	***	***	NOE-89-2952-A
652.0	692.0	***	***	***	***	27	***	***	***	***	***	***	26	***	***	***	NOE-89-2895-A
678.0	718.0	***	***	***	***	28	***	***	***	***	***	***	26	***	***	***	NOE-89-3233-A

DRIVESHAFT & D.C

DRIVESHAFT & DOUBLE CARDAN C.V.

CV Axle Assembly (Cont'd)

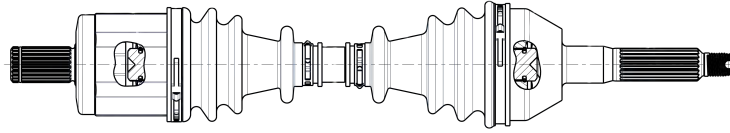

Compressed Length	Extended Length	Inboard Boot Number	Inboard Clamp 1 Number	Inboard Clamp 2 Number	Inboard Spline Length	Inboard Spline Tooth Count	Outboard Boot Number	Outboard Clamp 1 Number	Outboard Clamp 2 Number	Outboard Hub Dia.	Outboard Hub Length	Outboard Spline To Full Thread Length	Outboard Spline Tooth Count	Pin Dia.	Wheel Stud Length	Wheel Stud Thread	Part Number
688.0	728.0	***	***	***	***	28	***	***	***	***	***	***	26	***	***	***	NOE-89-2947-A
692.0	733.0	***	***	***	***	27	***	***	***	***	***	***	26	***	***	***	NOE-89-2883-A
722.0	763.0	***	***	***	***	29/27	***	***	***	***	***	***	26	***	***	***	NOE-89-2894-A
743.0	783.0	***	***	***	***	22	***	***	***	***	***	***	26	***	***	***	NOE-89-2825-A

Drive Shaft Repair Kit

Repair Kit Type	Tubing Dia. And Wall	Part Number
FIXED CENTER SECTION	3.000 X .083	N135-254
SLIP CENTER SECTION	3.000 X .083	N135-254-1

DRIVESHAFT & DOUBLE CARDAN C.V.

Driveshaft Kit

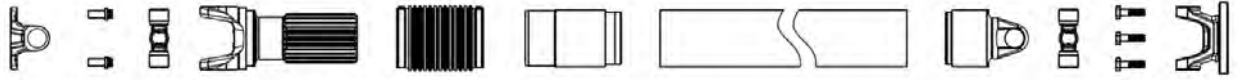

DL Series	Material	Driveshaft Style	Part Number
1350	Aluminum	Unwelded	PK-0510GT-AL
1350	Aluminum	Unwelded	PK-1114GT-AL
1350	Aluminum	Unwelded	PK-1517GTM-AL
1350	Aluminum	Unwelded	PK-1520GT350-AL
1350	Aluminum	Unwelded	PK-1522GTA-AL
1350	Aluminum	Unwelded	PK-1822GTM-AL

Steering Shaft Assembly

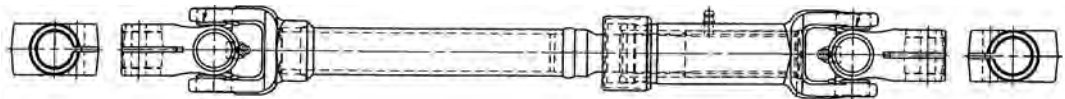

DL Series	Tubing Dia. And Wall	CL To CL Max. Extended Length	CL To CL Collapsed Length	Part Number
1000 Series				
		A-2.312	B-0.938	C-1.500
1000	1.250 X .120	63.940	62.190	N100-170

DRIVESHAFT & DOUBLE CARDAN C.V.

PTO / AUX SHAFT - SHIELDING SYSTEM

68-1000

FB-N1000 Shield Kit

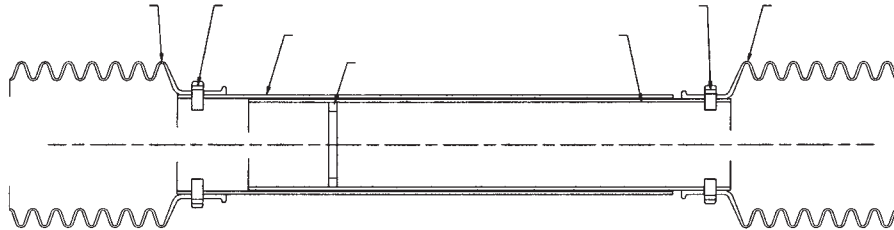

Consists of:

- 1) FB-275-SP Bell
- 1) FB-300-SP Bell
- 1) PT-2.75-60.00" Inner Shield Tube
- 1) PT-3.00-60.00" Outer Shield Tube
- 4) FN-275 Shield Bearing
- 4) FN-300 shield Bearing
- 1) 2294-4 Shield Support Bearing
- 1) FBIS-99.6 Instruction Sheet

68-0275

FB-275-SP Replacement Bell Kit

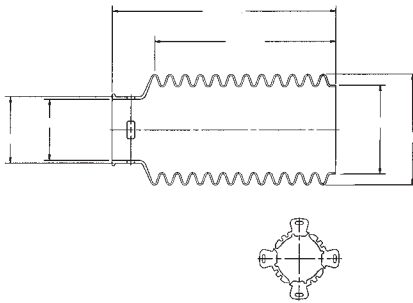

Consists of:

- 1) FB-275-SP Bell
- 4) FN-275 Shield Bearing

68-0300

FB-300-SP Replacement Bell Kit

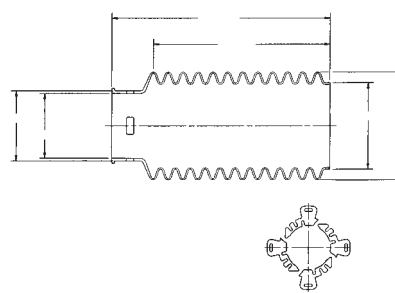

Consists of:

- 1) FB-300-SP Bell
- 4) FN-300 Shield Bearing

DRIVESHAFT & DOUBLE CARDAN C.V.

PTO / AUX SHAFT - SHIELDING SYSTEM

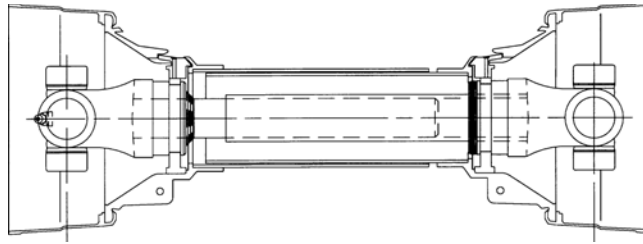

DL Series	Driveshaft Style	CL To CL Max. Extended Length	CL To CL Collapsed Length	Part Number
1000 Series A-2.312 B-0.938 C-1.500				
1000	Type 1	38.000	26.750	58-0627
1000	Type 1	62.000	38.750	58-0639
1000	Type 1	86.000	50.750	58-0651
1200 Series A-2.562 B-1.063 C-1.812				
1200	Type 1	38.000	27.250	58-1227
1200	Type 1	62.000	39.250	58-1239
1200	Type 1	86.000	51.250	58-1251
1800 Series B-1.00 C-2.34				
1800	Type 1	62.000	40.000	58-1840
1800	Type 1	86.000	52.000	58-1852
2000 Series A-2.625 B-1.125 C-1.85				
2000	Type 1	44.187	28.187	58-2028
2000	Type 1	68.312	40.000	58-2040
2000	Type 1	80.25	52.000	58-2052
2200 Series A-3.218 B-1.250 C-2.06				
2200	Type 1	44.500	28.500	58-2229
2200	Type 1	65.000	39.000	58-2239
2200	Type 1	77.000	51.000	58-2251
2600 Series B-1.37 C-2.81				
2600	Type 1	42.625	28.875	58-2629
2600	Type 1	62.625	38.250	58-2639
2600	Type 1	75.375	51.000	58-2651
N44 Series B-1.31 C-2.79				
N44	Type 1	41.937	25.500	58-4429
N44	Type 1	65.000	39.000	58-4439
N44	Type 1	76.437	50.437	58-4451

DRIVESHAFT & D.C

DRIVESHAFT & DOUBLE CARDAN C.V.

Notes



THE DRIVELINE EXPERTS

Small Parts

SECTION 10

SUB SECTION

Driveline Weight

Neapco Ultra-Performance
Universal Joint Grease

PTO Friction Disc

PTO Safety Shield Kit

Slip Yoke-Stub Shaft Assembly
(Includes U-Joint)

Drive Shaft Sleeve

Increasing Bushing

Pilot Reducer

Dust Seal

AND MUCH MORE!



**Manufacturing Driveline Solutions®
in the USA Since 1921.**

NeapcoAftermarket.com

©Neapco LLC 2023

SMALL PARTS

DRIVELINE WEIGHT

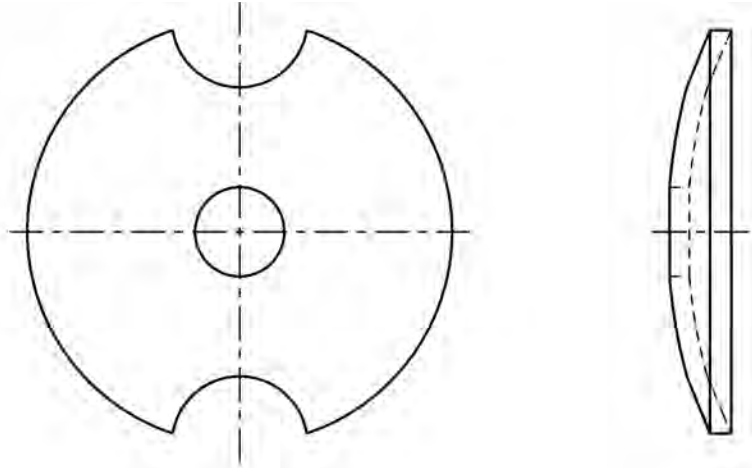

Material	Unit Weight Grams	Unit Weight Ounces	Quantity Per Box	Thickness	Width	Tube Dia.	Part Number
Steel	4.0	0.14	300	0.062	0.875	1.250 AND UP	DLW-1
Steel	50.0	1.76	50	0.125	1.625	2.000 AND UP	DLW-17
Steel	5.0	0.17	250	0.062	0.969	1.250 AND UP	DLW-2
Steel	8.0	0.28	200	0.062	1.188	1.250 AND UP	DLW-3
Steel	42.0	1.48	50	0.125	1.625	1.250 AND UP	DLW-30
Steel	10.0	0.35	150	0.062	1.312	1.250 AND UP	DLW-4
Steel	20.0	0.70	250	0.125	1.312	1.250 AND UP	DLW-5
Steel	30.0	1.05	150	0.188	1.312	1.250 AND UP	DLW-6

NEAPCO ULTRA-PERFORMANCE UNIVERSAL JOINT GREASE

Product Size	Part Number
14 oz. x Case of 10	NPPSG-14SX10
14 oz. x Case of 10	NPPSG-14X10
2 oz.	NPPSG-2
4 oz.	NPPSG-4
8 oz.	NPPSG-8

UJ GREASE AND SLIP SPLINE GREASE

Product Size	Part Number
2 oz.	NPPSG-2S

PTO FRICTION DISC

DL Series	Outside Dia.	Quantity	Part Number
2200 Series		A-3.329 B-1.250	
2200	6.88	2	61-2200

SMALL PARTS

PTO SAFETY SHIELD KIT

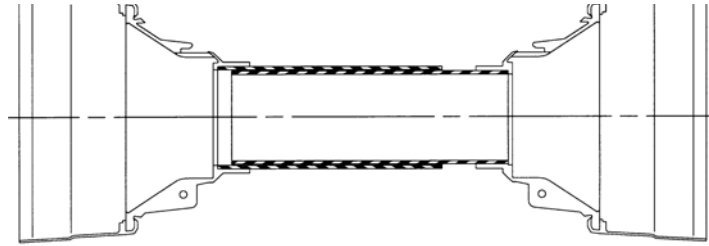

68-1000

FB-N1000 Shield Kit

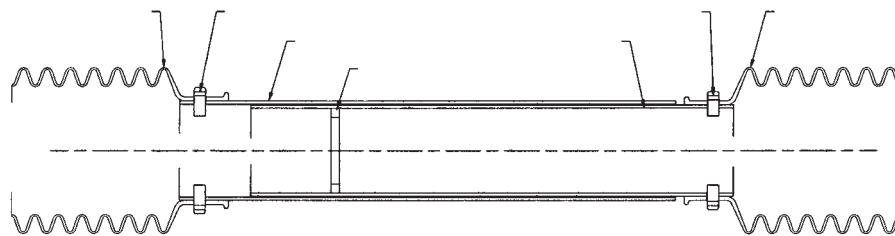

Consists of:

- 1) FB-275-SP Bell
- 1) FB-300-SP Bell
- 1) PT-2.75-60.00" Inner Shield Tube
- 1) PT-3.00-60.00" Outer Shield Tube
- 4) FN-275 Shield Bearing
- 4) FN-300 shield Bearing
- 1) 2294-4 Shield Support Bearing
- 1) FBIS-99.6 Instruction Sheet

68-0275

FB-275-SP Replacement Bell Kit

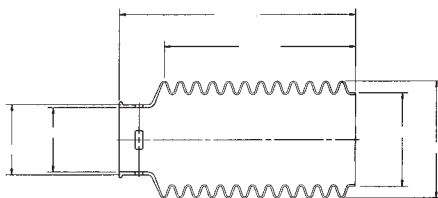

Consists of:

- 1) FB-275-SP Bell
- 4) FN-275 Shield Bearing

68-0300

FB-300-SP Replacement Bell Kit

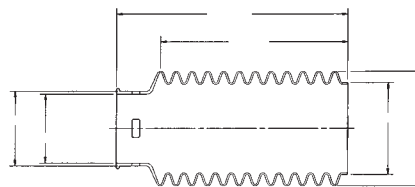

Consists of:

- 1) FB-300-SP Bell
- 4) FN-300 Shield Bearing

PTO SAFETY SHIELD KIT(Cont'd)

DL Series	Bell OD	Compressed Length	Length	Maximum Extended Length	Thickness	Used On	Part Number
B&P8							
B&P8	8.000	***	60.000	***	***	***	69-2648
W2100							
W2100	5.250	***	60.000	***	***	***	69-0648
W2500							
W2500	7.062	***	60.000	***	***	***	69-2248
WI							
WI	6.125	***	60.000	***	***	***	69-1248
***	5.000	***	10.176	8.237	***	***	68-0275
***	5.000	***	10.176	8.237	***	***	68-0300
***	***	50.352	10.176	8.237	***	***	68-1000
***	***	48.227	***	76.102	***	***	68-1001
***	***	63.102	***	88.602	***	***	68-1072
***	***	***	***	***	0.335	68-0275	FN-275-4
***	***	***	***	***	0.335	68-0300	FN-300-4

SLIP YOKE-STUB SHAFT ASSEMBLY (INCLUDES U-JOINT)

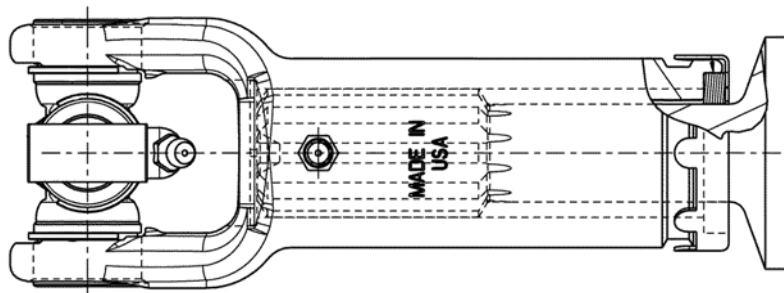

DL Series	Spine/Number Teeth	Butt Dia.	CL To Weld Point Collapsed	CL To Weld Point Extended	U-joint	Part Number
1000 Series			A-2.312	B-0.938	C-1.500	
1000	1.125-10	1.842	6.090	7.960	1-0170	11-1750

SMALL PARTS

DRIVE SHAFT SLEEVE

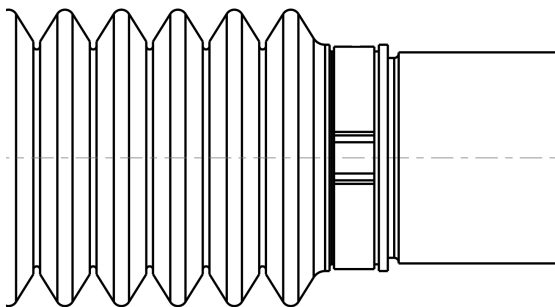

DL Series	Spline/Number Teeth	Boot Apexes	Bore Type	Butt Dia.	CL To End Of Spline	End Of Spline To Radius	End Of Spline To Weld	Inside Dia.	Length Of Spline	Outside Dia.	Description	U-joint	Part Number
1410 Series A-4.438 B-1.188													
1410	1.43-20 based on 22	6	Round	2.260	8.600	5.910	4.980	1.810	4.110	2.600	Includes (1) yoke shaft, (1) boot, (1) sleeve, (1) u-joint, (2) clamps, (1) strap	2-0054G	N3-1411-1411X

INCREASING BUSHING

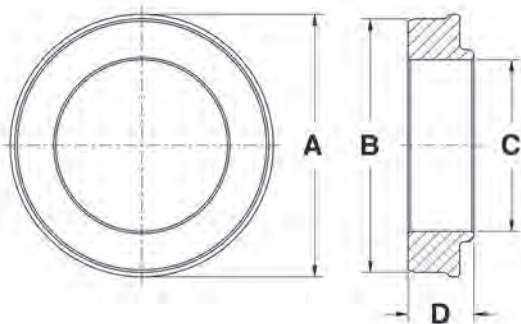

Butt Dia.	Tube Size Max	A Outside Dia.	B Tube Pilot	C Inside Dia.	D Length	Quantity	Part Number
2.500 X 0.100	3.500 X .065	3.000	2.875	2.281	0.875	1	5361
2.500 X 0.100	3.500 X .065	3.500	3.375	2.281	0.875	1	5362
3.000 X 0.130	3.500 X .065	3.500	3.375	2.719	0.875	1	5363
3.000 X 0.130	4.000 X .083	4.000	3.875	2.719	0.875	1	5364
3.500 X 0.160	4.000 X .083	4.000	3.875	3.188	0.875	1	5365
3.500 X 0.160	4.500 X .083	4.500	4.375	3.188	1.000	1	5366
3.000 X 0.080	3.500 X .083	3.500	3.344	2.838	0.875	1	5368
2.500 X 0.080	3.500 X .083	3.500	3.344	2.328	0.875	1	5369
3.500 X 0.080	4.000 X .083	4.000	3.844	3.338	0.875	1	5373

PILOT REDUCER

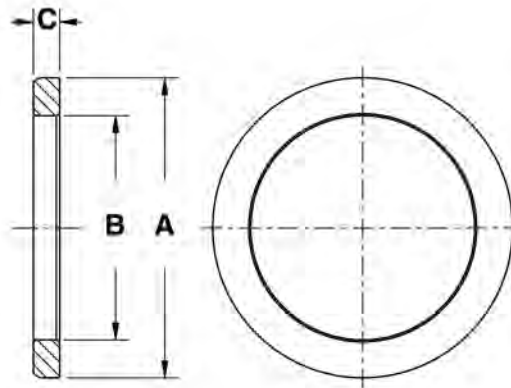

A Outside Dia.	B Inside Dia.	C Thickness	Quantity	Part Number
2.688	2.000	0.240	1	5324

DUST SEAL

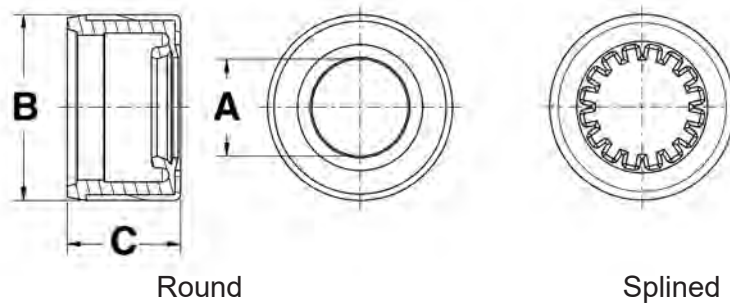

DL Series	Type	A Inside Dia.	B Outside Dia.	C Height	Lubrication Type	Quantity	Part Number
1000/1210							
1000/1210	Round	1.000	2.000	1.312	***	1	280196
1310 THRU 1410							
1310 THRU 1410	Round	1.156	2.125	1.312	NON-GREASABLE	1	280194
1310 THRU 1410	Round	1.156	2.125	1.312	GREASABLE	1	280194-1
1350/1410							
1350/1410	Round	1.188	2.125	0.750	***	1	ND3A
1410/1480							
1410/1480	Round	2.250	2.312	0.750	***	1	ND3H

SMALL PARTS

DUST SEAL (Cont'd)

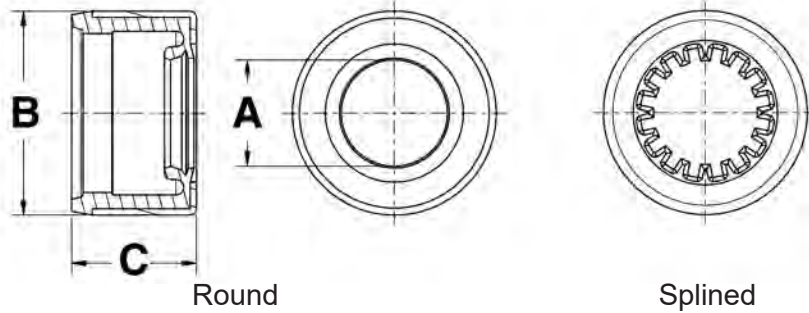

DL Series	Type	A Inside Dia.	B Outside Dia.	C Height	Lubrication Type	Quantity	Part Number
		1550 Series		A-5.250 B-1.375			
1550	Round	1.406	2.578	.906	***	1	ND4J
		1610 Series		A-5.321 B-1.875			
1610	Round	1.625	2.641	.938	***	1	N5-86-68
1710/1760	Round	2.062	3.344	.938	***	1	N6.3-86-18
		1810 Series		A-7.547 B-1.938			
1810	Round	2.516	3.969	.953	***	1	N6.5-86-38
		1280/1310					
1280/1310	Splined	1.250-16	1.688	.656	***	1	ND2K
		1310 THRU 1410					
1310 THRU 1410	Splined	1.375-16	2.125	1.000	***	1	280195
		1350 / 1410					
1350 / 1410	Splined	1.500-16	1.906	.750	***	1	ND3K
1350/1410	Splined	1.375-16	1.906	.750	***	1	ND3G
		1550 Series		A-5.250 B-1.375			
1550	Splined	1.750-16	2.344	.750	***	1	ND4K
		7260 Series		A-3.000 B-1.078 C-2.125			
7260	Splined	1.250-16	1.781	.750	***	1	280200

WELCH PLUG

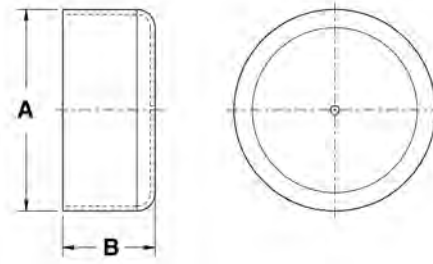

DL Series	A Height	B Outside Dia.	Quantity	Part Number
1610 Series		A-5.321	B-1.875	
1610	0.438	2.203	1	N5-68-54
1710/1760				
1710/1760	0.531	2.750	1	N6-68-51
1710 Series		A-6.094	B-1.938	
1710	1.250	2.750	1	N6-68-71
1760 Series		A-7.000	B-1.938	
1760	1.094	2.750	1	N6.3-68-14
1810 Series		A-7.547	B-1.938	
1810	0.625	3.250	1	N8-68-13

U-BOLT KIT

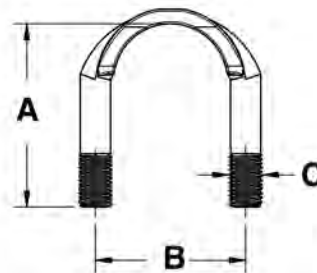

DL Series	Bearing Dia.	A Stud Length	B CL To CL Of Studs	C Thread Size	Thread Length	Torque (ft.-lbs.)	Used With U-joint	Quantity	Part Number
1310/1330									
1310/1330	1.062	1.726	1.406	5/16-24	0.55	14-17	1-0153 / 1-0154 / 1-0200 / 2-4800	1	1-0089
1350/1410									
1350/1410	1.188	2.000	1.656	3/8-24	0.62	20-24	2-0053 / 2-0054	1	1-0099

SMALL PARTS

U-BOLT KIT (Cont'd)

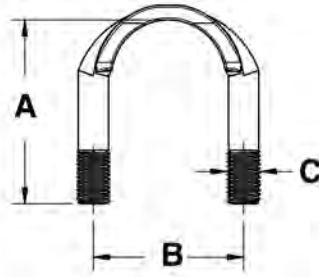

DL Series	Bearing Dia.	A Stud Length	B CL To CL Of Studs	C Thread Size	Thread Length	Torque (ft.-lbs.)	Used With U-joint	Quantity	Part Number
1480/1550									
1480/1550	1.375	2.281	1.906	7/16-20	0.72	32-37	3-0188 / 3-0155	1	1-0109
1310/1330									
1310/1330	1.125	1.828	1.578	5/16-24	0.72	14-17	2-4900	1	1-0189

U- JOINT BEARING CAP RETAINER

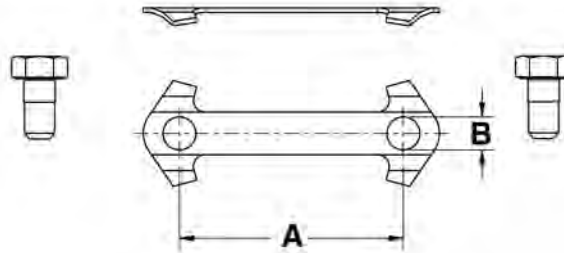

DL Series	A CL To CL	B Hole Dia.	Used With U-joint	Quantity	Part Number
1610 Series A-5.321 B-1.875					
1610*	2.313	0.344	4-0279 / 4-0674	1	1-2858
1710 / 1760 / 1810					
1710 / 1760 / 1810*	2.437	0.406	5-0280 / 6-0675 / 6-0677 / 6-0407 / 6-0676 / 6-0281	1	1-2859
20R / 25R					
20R / 25R*	***	***	6-0020 / 6-0025	1	NKIT-RPL25-20
SPL170/SPL250					
SPL170/SPL250*	***	***	6-1170 / 6-1250	1	1-0070

BEARING STRAP KIT

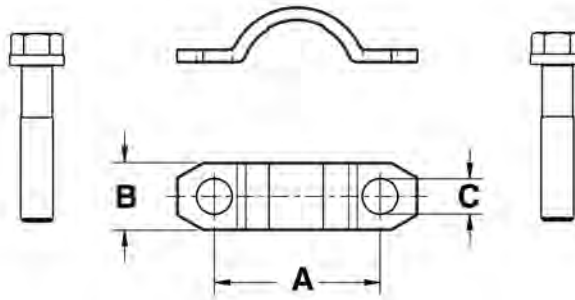

DL Series	Bearing Dia.	A CL To CL	B Strap Width	C Bolt Hole Dia.	Bolt Length	Thread Size	Torque (ft.-lbs.)	Used With U-joint	Quantity	Part Number
7290 Series A-3.563 B-1.126 C-2.625										
7290*	1.125	1.531	0.625	0.281	0.594	1/4-28	13-18	2-1175	1	1-0018
1350 / 1410										
1350 / 1410*	1.188	1.806	0.750	0.344	0.750	5/16-24	30-35	2-0053 / 2-0054	1	1-0019
1350 / 1410*	1.188	1.656	0.750	0.344	1.500	5/16-24	30-35	2-0053 / 2-0054	1	1-0020
1480 / 1550										
1480 / 1550*	1.375	2.125	0.844	0.406	0.750	3/8-24	55-60	3-0188 / 3-0155	1	1-0021
1310 / 1330										
1310 / 1330*	1.062	1.594	0.688	0.281	0.594	1/4-28	13-18	1-0153 / 1-0154 / 1-0200 / 2-4800	1	1-0022
7260 Series A-3.000 B-1.078 C-2.125										
7260*	1.078	1.500	0.562	0.266	0.625	1/4-28	13-18	1-6300 / 1-6301	1	1-0023
1310 / 1330										
1310 / 1330*	1.062	1.594	0.625	0.312	1.500	5/16-24	30-35	1-0153 / 1-0154 / 1-0200 / 2-4800	1	1-0024
3R Series A-3.563 B-1.125 C-2.563										
3R*	1.125	1.812	0.625	0.328	1.500	5/16-24	30-35	2-3010 / 2-3011 / 2-3111	1	1-0025
1485 / 1555										
1485 / 1555*	1.375	1.938	0.750	0.344	1.281	5/16-24	14-17	3-0486 / 3-1555	1	1-0030
1610 Series A-5.321 B-1.875										
1610*	1.875	2.500	1.000	0.406	0.750	3/8-24	45-60	4-0674	1	1-0045
1710 / 1760 / 1810										
1710 / 1760 / 1810*	1.938	2.812	1.062	0.531	1.000	1/2-20	115-135	6-0675 / 6-0676 / 6-0677	1	1-0046
NPL170/SPL170										
NPL170/SPL170*	2.166	3.234	1.094	0.500	0.984	M12x1.25	115-135	6-1170	1	N170-70-08X
NPL170/SPL170 *	2.166	3.234	1.094	0.500	0.984	M12x1.25	***	6-1170	1	N170-70-18X

* SPL - Spicer® Life Series driveshafts is a registered trademark of Dana Limited

SMALL PARTS

BEARING STRAP KIT (Cont'd)

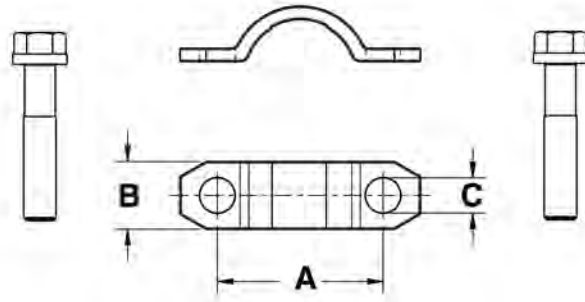

DL Series	Bearing Dia.	A CL To CL	B Strap Width	C Bolt Hole Dia.	Bolt Length	Thread Size	Torque (ft.-lbs.)	Used With U-joint	Quantity	Part Number
1310 Series A-3.469 B-1.063										
1310*	1.063	***	0.630	***	***	***	***	***	50	N2-95-29
NPL250/SPL250										
NPL250/SPL250*	2.359	3.438	1.125	0.500	0.984	M12x1.25	115-135	6-1250	1	N250-70-08X
NPL250/SPL250*	2.359	3.438	1.125	0.500	0.984	M12x1.25	***	6-1250	1	N250-70-18X
1330/1330XC/1350/1355/7290/S44/P55-55-2/P55-55-675										
1330/1330XC/1350/1355/7290/S44/ P55-55-2/P55-55-675*	***	***	***	***	***	***	***	***	50	N3-95-19
1410/1415										
1410/1415*	***	***	***	***	***	***	***	***	50	N3-95-29
SPL90 / SPL100										
SPL90 / SPL100*	1.625	2.312	***	0.391	0.750	3/8-24	45-60	4-1090 / 4-1091	1	N90-70-28X

* SPL - Spicer® Life Series driveshafts is a registered trademark of Dana Limited

SMALL PARTS

BOLT



Thread Dia.	Grade	Length	Number Of Bolts	Quantity	Part Number
5/16-24 UNF	8	1.500	100	100	1-0790
5/16-24 UNF	8	1.250	***	4	37050X
3/8-16	***	0.750	***	25	50-0449
1/4-28	8	0.562	***	100	6029562
3/8-24	***	1.250	4	1	N131F
7/16-20	***	1.250	***	1	N135F
1/2-20	***	1.500	***	1	N148F
3/8-24	***	1.250	8	1	N161F
3/4-16 UNF	5	1.500	***	4	N500415-9

SNAP RING

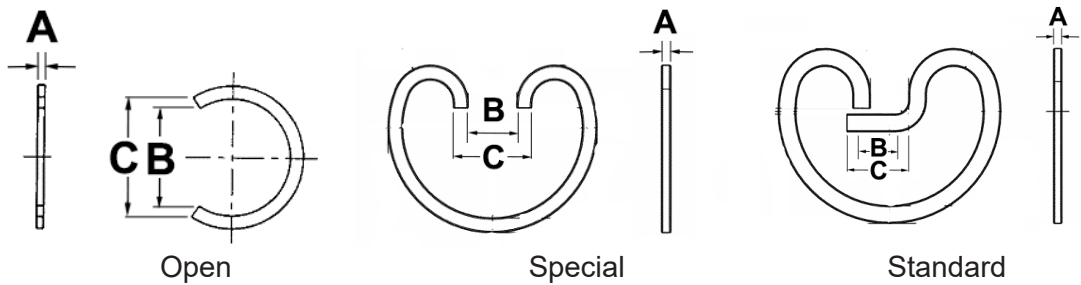

DL Series	Type	A Thickness	Color	B Nominal Id	C Nominal Od	Quantity	Part Number
20R/25R							
20R/25R	Open	0.078	black	***	2.290	4	6-7331
3R Series A-3.563 B-1.125 C-2.563							
3R	Open	0.089	black	0.995	***	100	1-8297
600							
600	Open	0.050	copper	0.838	***	100	1-1077
7260 Series A-3.000 B-1.078 C-2.125							
7260	Open	0.062	copper	0.964	***	100	1-1771

SMALL PARTS

SNAP RING (Cont'd)

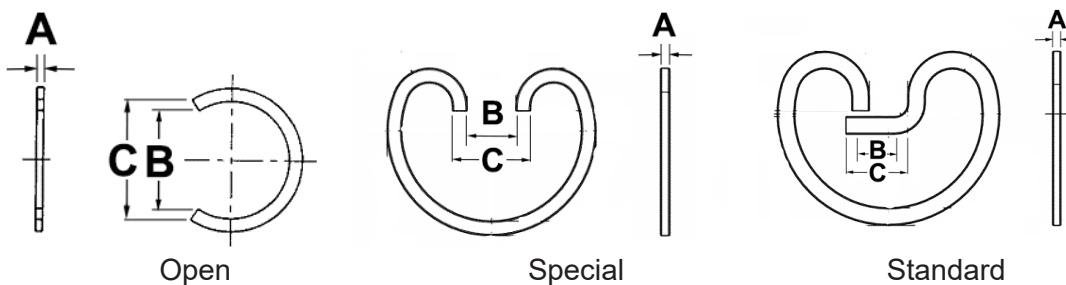

DL Series	Type	A Thickness	Color	B Nominal Id	C Nominal Od	Quantity	Part Number
***	Open	0.094	black	0.909	***	100	1-7180
***	Open	0.095	black	1.013	***	100	1-7330
***	Open	0.059	black	0.965	***	100	1-7700
1350/1410							
1350/1410	Special	0.059	grey	***	1.328	100	3-7801
1310/1330							
1310/1330	Standard	0.059	black	***	1.190	100	3-7700
1310/1330	Standard	0.062	white	***	1.205	100	3-7705
1310/1330	Standard	0.063	blue	***	1.205	100	3-7706
1310/1330	Standard	0.058	copper	***	1.215	100	3-7820
1350/1410							
1350/1410	Standard	0.056	gray	***	1.314	100	3-7810
1350/1410	Standard	0.059	black	***	1.370	100	3-7811
1350/1410	Standard	0.060	red	***	1.370	100	3-7812
1350/1410	Standard	0.061	white	***	1.370	100	3-7813
1350/1410	Standard	0.062	brown	***	1.370	100	3-7814
1350/1410	Standard	0.063	yellow	***	1.370	100	3-7815
1350/1410	Standard	0.064	grey	***	1.370	100	3-7816
1350/1410	Standard	0.065	blue	***	1.370	100	3-7817
1350/1410	Standard	0.066	violet	***	1.370	100	3-7818
1350/1410	Standard	0.067	pink	***	1.370	100	3-7819
1485							
1485	Standard	0.057	silver	***	1.500	100	3-7805

DRIVE SHAFT BOOT

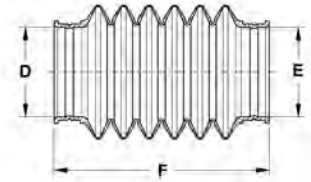

DL Series	Material	D/E Inside Dia.	F Length	Apexes	Bell Dia.	Grease (grams)	Inboard/ outboard	Installed Approximate Length	Non-installed pproximate Length	Shaft Dia.	Quantity	Part Number
***	Rubber	1.656 / 1.656	3.109	3	***	***	***	***	***	***	1	N2112504
***	Rubber	1.875 / 2.094	3.750	5	***	***	***	***	***	***	1	N2118734
***	Rubber	4.516 / 4.516	7.797	8	***	***	***	***	***	***	1	N211959X
NPL170/250, SPL170/250												
NPL170/250, SPL170/250*	Rubber	4.51 / 4.51	7.800	***	***	***	***	***	***	***	1	N211959X1
***	Rubber	4.156 / 4.203	10.703	11	***	***	***	***	***	***	1	N211987X
NPL170/SPL170												
NPL170/ SPL170*	Rubber	3.69 / 3.69	7.950	***	***	***	***	***	***	***	1	N212059X
NPL170/250, SPL170/250												
NPL170/250, SPL170/250*	Rubber	3.42 / 3.42	5.850	***	***	***	***	***	***	***	1	N5009494X
NPL170/250, SPL170/250*	Rubber	3.42 / 3.42	5.850	***	***	***	***	***	***	***	1	N5009494X1
***	Rubber	***	***	***	3.000	35.4-49.6	Outboard	4.000	4.130	0.760	1	NOE-09-9300-A
***	Rubber	***	***	***	2.700	78-92.1	Inboard	4.000	4.130	0.760	1	NOE-09-9312-A
***	Rubber	0.728/2.488	4.098	6	2.988	***	Outboard	3.349	4.098	0.875	1	NOE-09-9451-A
***	Rubber	0.826/2.909	4.224	6	3.666	***	Outboard	3.566	4.224	0.880	1	NOE-09-9452-A
***	Rubber	0.826/2.649	3.704	6	2.913	***	Inboard	***	3.704	0.880	1	NOE-09-9453-A
***	Rubber	0.860/3.125	3.540	4	***	***	***	***	3.540	***	1	NOE-09-9896-A

* SPL - Spicer® Life Series driveshafts is a registered trademark of Dana Limited

SMALL PARTS

WASHER



Inside Dia.	Outside Dia.	Thickness	Quantity	Part Number
1.281	2.750	0.125	4	N230123-6
0.812	1.750	0.188	4	N230129
0.750	1.250	0.188	4	N500357-17

BALL SEAL



DL Series	A Ball Dia.	C Seal Outside Dia.	D Seal Height	Part Number
1310 thru 1350				
1310 thru 1350	1.125	1.342	0.163	N2-86-1298
1310 thru 1350	***	***	***	N2-86-418

SHAFT NUT



Thread Dia.	Flange Dia.	Width Across Flats	Thickness	Quantity	Part Number
1-20 UNEF	***	1.281	.562	4	N16-74-101
1-1/4-18 UNEF	2.500	1.625	.625	1	N20-74-91
1-1/4-18 UNEF	2.062	1.625	.625	4	N231502

SMALL PARTS

LUBE FITTING



Thread Dia.	Overall Length	Type	Quantity	Part Number
1/8 PTF	0.688	Standard	10	0610-B
1/4-28 NF Tapered	0.594	Standard	20	0641-B
1/4-28 UNF	0.469	Standard	10	1981
1/4-28 NF Tapered	0.438	Flush	10	2915
10-32 NF	0.344	Flush	10	2920

U-JOINT FASTENER BOLT KIT

Grade	Length	Thread Dia.	Quantity	Part Number
8	1.750	1/2-20 UNF	4	NCSC8-20-52

MULTI PURPOSE RETAINING RING

Thickness	Inside Dia.	Outside Dia.	Ring Plier Dia.	Quantity	Part Number
0.350	1.500	1.625	***	1	N231259
0.059	1.098	***	0.197	1	NOE-99-0481-A
0.037	***	0.942	0.166	1	NOE-99-7809-A

DRIVE SHAFT CENTERING TOOL

DL Series	Used With U-joint	Part Number
1480*	3-0188	1480
1550*	3-0155	1550
1600/1610*	4-0279	1600-1610
1700/1710*	5-0280	1700-1710
1760 Series A-7.000 B-1.938		
1760*	6-0407	1760
1810 Series A-7.547 B-1.938		
1810*	6-0281	1810
2R		
2R*	1-3600 / 1-3650	2R
55N		
55N*	3-0045	55N
L12N		
L12N*	1-1275	L12N
L14N		
L14N*	1-2075	L14N
L16N/35N		
L16N/35N*	2-2275	L16N-35N
NPL-170		
NPL-170*	6-1170	SPL-170
NPL-250		
NPL-250*	6-1250	SPL-250
NPL-90		
NPL-90*	4-1090	SPL-90
PL-140		
PL-140*	***	SPL-140
RPL-20		
RPL-20*	6-0020	RPL-20
RPL-25		
RPL-25*	6-0025	RPL-25

* SPL - Spicer ® Life Series driveshafts is a registered trademark of Dana Limited

SMALL PARTS

STRAP

DL Series	Bearing Dia.	Bolt Hole Dia.	CL To CL	Strap Width	Used With U-joint	Used With UJ Strap Kit	Quantity	Part Number
7260 Series A-3.000 B-1.078 C-2.125								
7260	1.078	0.265	1.50	0.560	1-6300 / 1-6301	1-0023	1	72620

HARDWARE KIT

Used With U-joint	Description	Quantity	Part Number
1-6300	Contains: (4) Snap rings, .059 thk., .952 id., (1), 0641-B Zerk, (1) plastic lube plug	1	1-2822
6-0675 / 6-0676 / 6-0677	Fits driveline series 1710-1810. Contains: (4) ea. bearing strap and lockstrap bolts, (2) ea. bearing straps and lockstraps, (2) lube fittings.	1	1-2865

PTO YOKE & SHAFT ALIGNMENT KEY

Description	Quantity	Part Number
Contains (25): Width: 0.187" x Height: 0.187", Length: 1.0"	25	50-1501
Contains (25): Width: 0.250" x Height: 0.250", Length: 1.0"	25	50-1502
Contains (25): Width: 0.312" x Height: 0.312", Length: 1.0"	25	50-1503
Contains (25): Width: 0.1875" x Height: 0.422", Length: 1.0"	25	50-1504
Contains (25): Width: 0.250" x Height: 0.422", Length: 1.0"	25	50-1505
Contains (25): Width: 0.3125" x Height: 0.422", Length: 1.0"	25	50-1506
Contains (25): Width: 0.312" x Height: 0.289", Step wdth.: 0.250", Step hgt.: 0.131", Length: 1.25"	25	50-1511
Width: 0.187" x Height: 0.187", Length: 12.0"	1	50-3501
Width: 0.250" x Height: 0.250", Length: 12.0"	1	50-3502
Width: 0.312" x Height: 0.312", Length: 12.0"	1	50-3503
Width: 0.312" x Height: 0.289", Step wdth.: 0.250", Step hgt.: 0.131", Length: 12.0"	1	50-3511
Width: 0.250" x Height: 0.226", Step wdth.: 0.187", Step hgt.: 0.100", Length: 12.0"	1	50-3512
Width: 0.375" x Height: 0.352", Step wdth.: 0.312", Step hgt.: 0.162", Length: 12.0"	1	50-3513

PTO TUBE PIN

Description	Quantity	Part Number
Contains (10): OD: 0.339", Length: 1.968"	10	50-0112
Contains (10): OD: 0.339", ID: 0.315", Length: 2.36"	10	50-0412
Contains (10): OD: 0.417", ID: 0.394", Length: 2.95"	10	50-0512
Contains (10): OD: 0.417", ID: 0.394", Length: 2.76"	10	50-0612
Contains (10): OD: 0.417", ID: 0.394", Length: 3.15"	10	50-1080
Contains (10): OD: 0.417", ID: 0.394", Length: 3.54"	10	50-1090
Contains (10): OD: 0.496", ID: 0.472", Length: 3.15"	10	50-1280
Contains (10): OD: 0.339", ID: 0.315", Length: 2.65"	10	50-2212
Contains (10): OD: 0.417", ID: 0.394", Length: 2.65"	10	50-2312

PTO REPAIR KIT

Inside Dia.	Outside Dia.	Series	Width	Description	Quantity	Part Number
***	***	***	***	Contains (2) 0666 nylon bearings, (1) 0667 lock ring	1	56-0666
***	***	***	***	Contains (2) BPB2-101 retainer I/O	2	56-2101
***	***	***	***	Contains (2) BPB2-102 retainer I/O	2	56-2102
***	***	***	***	Contains (2) WSB2-2122 retainer I/O	2	56-2122
***	***	***	***	Contains (2) WSB4-2223 retainer I/O	2	56-2223
***	***	***	***	Contains (2) BPB4-103 retainer I/O	2	56-4103
***	***	***	***	Contains (2) BPB6-106 retainer I/O	2	56-6106
***	***	***	***	Contains (2) BPB8-108 retainer I/O	1	56-8108
2.000	2.281	2000, 2200	0.250	Contains (1) Nylon Bearing	1	56-2295
***	***	***	***	Contains (1) Pin 1.79" x 0.31", (1) spring 1.19" x 0.47". (1) washer 0.59" x 0.06"	3	56-0040
***	***	***	***	Contains (1) CL301 back up ring, (1) CL304 spring, (1) CL303 collar, (1) CL302 back up ring, (1) QL 205 snap ring and (3) 0.5" balls	8	56-0200
***	***	***	***	Contains (2) WPB2-06 retainers, 1000 series, 1.519" ID	2	56-0600
***	***	***	***	Contains (2) Nylon Bearing, 0.25" thk.	2	56-0604
***	***	***	***	Contains (1) 0611-1 spring, (1) 0613 snap ring, (2) 0614 balls, (1) 0615 collar	5	56-0615
***	***	***	***	Contains (2) WPB8-44 retainers, 44 series, 2.636" ID	2	56-0844
***	***	***	***	Contains (2) WPB2-L6 retainers, L600 series, 1.828" ID	2	56-1600
***	***	***	***	Contains (1) 0626-1 spring, (1) 1856-1 pin	2	56-1857

SMALL PARTS

PTO REPAIR KIT (Cont'd)

Inside Dia.	Outside Dia.	Series	Width	Description	Quantity	Part Number
***	***	***	***	Contains (2) WPB4-20 retainers, 2000 series, 2.00" ID	2	56-2000
***	***	***	***	Contains (3) 2004 nylon shield bearings, 0.31" thk.	3	56-2004
***	***	***	***	Contains (2) WPB6-22 retainers, 2200 series, 2.00" ID	2	56-2200
***	***	***	***	Contains (1) Nylon Bearing, 2.00" ID, 0.25" thk.	1	56-2294
***	***	***	***	Contains (1) 1899 nylon bearing, (1) 2297 lock ring, (1) 2298 washer	3	56-2300
***	***	***	***	Contains (2) WSB6-2324 retainer I/O	2	56-2324
***	***	***	***	Contains (1) 0626-1 spring, (1) 2446 pin	2	56-2446
***	***	***	***	Contains (2) WPB8-26 retainers, 2600 series, 2.868" ID	2	56-2600
***	***	***	***	Contains (4) 2604 nylon shield bearings, 0.31" thk.	4	56-2604
***	***	***	***	Contains (1) Nylon Bearing, 2.54" ID, 0.25" thk.	1	56-2646
***	***	***	***	Contains (1) 0613-2 lock ring, (4) 0614-1 bearings,(1) 2663 spring, (1) 2669 QD collar	7	56-2669
***	***	***	***	Contains (1) 2286-4 lock ring, (3) JD-51019 bearings, (1) SC-1 slide collar, (1) SC-4 spring	6	56-3001
***	***	***	***	Contains (2) BPB6-105 retainer I/O	2	56-6105
***	***	***	***	Contains (1) 2294-4 nylon bearing, OD: 2.52", ID: 2.01", Thickness: .25"	1	2294-4

PTO COLLAR

Inside Dia.	Outside Dia.	Collar Groove Width	Quantity	Part Number
1.270	2.250	0.349	1	2-1250
1.610	2.250	0.349	1	2-1625
1.900	2.250	0.349	1	2-1880
2.020	2.250	0.349	1	2-2030

PTO FRICTION CLUTCH

DL Series	CL To End Of Hub	Housing Dia.	Housing Length	Spline/Number Teeth	Part Number
B&P5	6.500	3.740	3.000	1.375-6	8-0402
W220	6.578	3.578	2.125	1.375-6	8-0452
W2200	5.438	3.740	2.250	1.375-6	8-0403
W2300	5.594	3.740	2.250	1.375-6	8-0401
W2300	6.062	3.578	2.125	1.375-6	8-0451
W2400	6.188	3.578	2.125	1.375-6	8-0450
WI	5.594	3.740	2.250	1.375-6	8-0400

SMALL PARTS

Notes

SMALL PARTS



THE DRIVELINE EXPERTS

Center Support

SUB SECTION

Dimensional Listing by Bearing ID

SECTION 11



**Manufacturing Driveline Solutions®
in the USA Since 1921.**

NeapcoAftermarket.com

©Neapco LLC 2023

CENTER SUPPORT

DIMENSIONAL REFERENCE

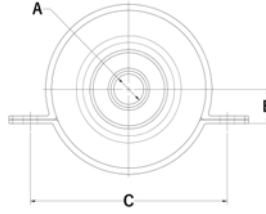

A Bore Inches	A Bore MM	B CL Of Bearing To Face	C CL To CL Of Mounting	Bolt Hole Dia.	Part Number
0.984	25.0	0.984	6.469	0.469 X 1.188 Slot	N214201

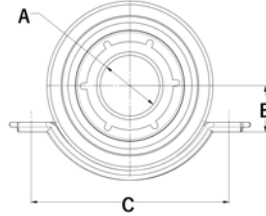

A Bore Inches	A Bore MM	B CL Of Bearing To Face	C CL To CL Of Mounting	Bolt Hole Dia.	Part Number
1.102	28.0	0.859	6.625	0.797 X 1.016 Slot	N216809

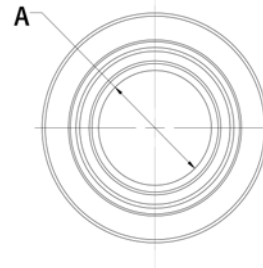

A Bore Inches	A Bore MM	B CL Of Bearing To Face	C CL To CL Of Mounting	Bolt Hole Dia.	Part Number
1.181	30.0	.	.	.	N212801

CENTER SUPPORT

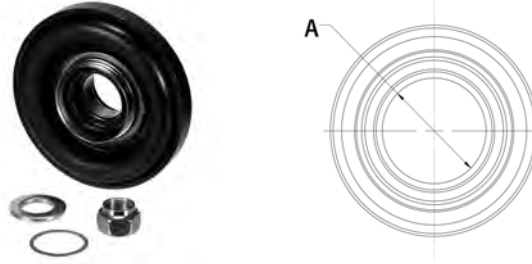

A Bore Inches	A Bore MM	B CL Of Bearing To Face	C CL To CL Of Mounting	Bolt Hole Dia.	Part Number
1.181	30.0	.	.	.	N212802

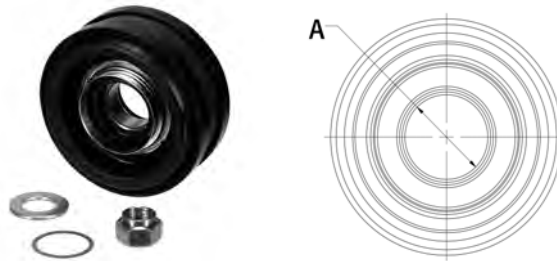

A Bore Inches	A Bore MM	B CL Of Bearing To Face	C CL To CL Of Mounting	Bolt Hole Dia.	Part Number
1.181	30.0	.	.	.	N212803

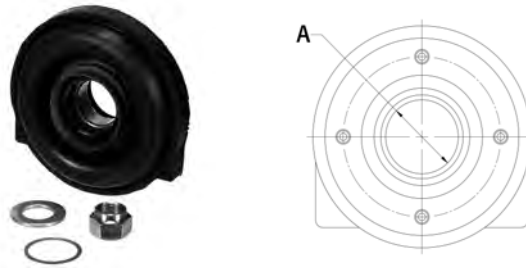

A Bore Inches	A Bore MM	B CL Of Bearing To Face	C CL To CL Of Mounting	Bolt Hole Dia.	Part Number
1.181	30.0	.	.	.	N212804

CENTER SUPPORT

DIMENSIONAL REFERENCE

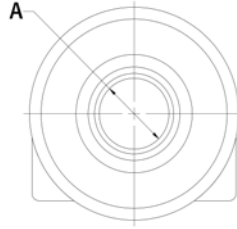

A Bore Inches	A Bore MM	B CL Of Bearing To Face	C CL To CL Of Mounting	Bolt Hole Dia.	Part Number
1.181	30.0	-	-	-	N237521

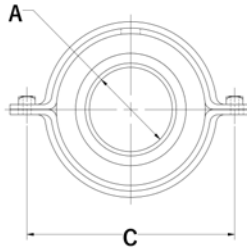

A Bore Inches	A Bore MM	B CL Of Bearing To Face	C CL To CL Of Mounting	Bolt Hole Dia.	Part Number
1.181	30.0	-	5.938	M8X1.25 Nuts	N213801

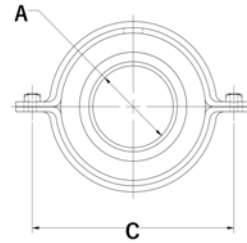

A Bore Inches	A Bore MM	B CL Of Bearing To Face	C CL To CL Of Mounting	Bolt Hole Dia.	Part Number
1.181	30.0	-	5.938	M10X1.25 Nuts	N213803

CENTER SUPPORT

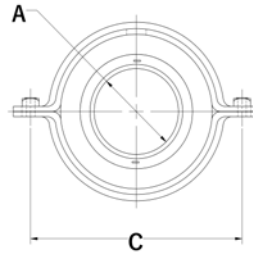

A Bore Inches	A Bore MM	B CL Of Bearing To Face	C CL To CL Of Mounting	Bolt Hole Dia.	Part Number
1.181	30.0	-	5.938	M10X1.25 Nuts	N213804

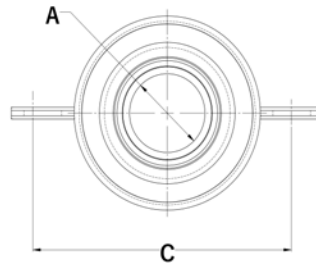

A Bore Inches	A Bore MM	B CL Of Bearing To Face	C CL To CL Of Mounting	Bolt Hole Dia.	Part Number
1.181	30.0	0.0	6.484	0.438 X 0.562 Slot	N227030

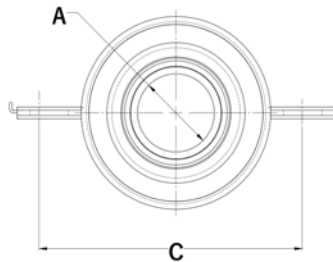

A Bore Inches	A Bore MM	B CL Of Bearing To Face	C CL To CL Of Mounting	Bolt Hole Dia.	Part Number
1.181	30.0	0.0	6.484	0.438 X 0.688 Slot	N216801

CENTER SUPPORT

DIMENSIONAL REFERENCE

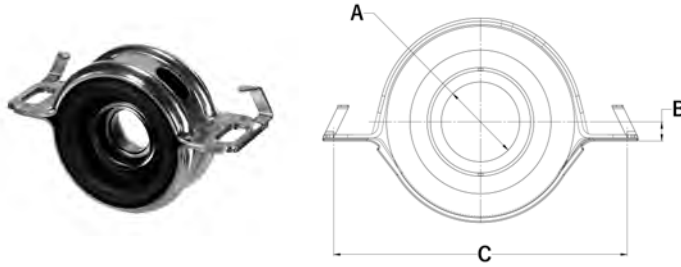

A Bore Inches	A Bore MM	B CL Of Bearing To Face	C CL To CL Of Mounting	Bolt Hole Dia.	Part Number
1.181	30.0	0.281	5.828	0.578 X 1.188 Slot	N213805

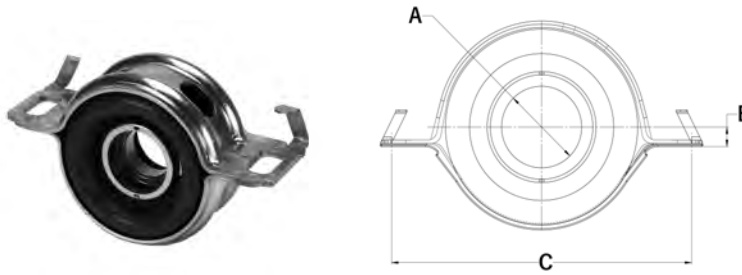

A Bore Inches	A Bore MM	B CL Of Bearing To Face	C CL To CL Of Mounting	Bolt Hole Dia.	Part Number
1.181	30.0	0.281	5.828	0.578 X 1.188 Slot	N213807

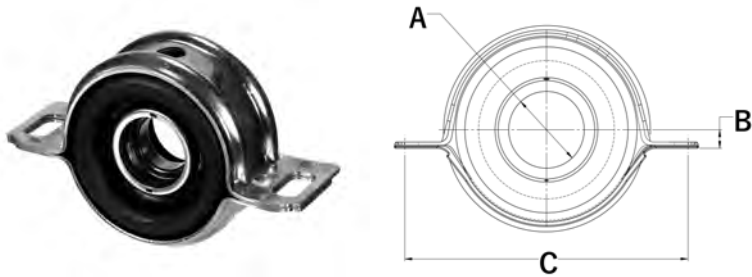

A Bore Inches	A Bore MM	B CL Of Bearing To Face	C CL To CL Of Mounting	Bolt Hole Dia.	Part Number
1.181	30.0	0.281	5.875	0.578 X 1.188 Slot	N223804

CENTER SUPPORT

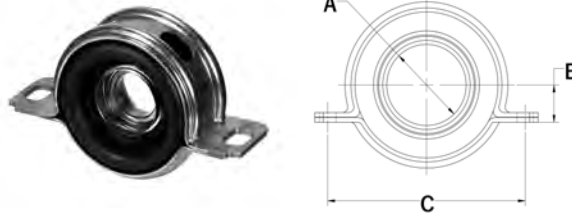

A Bore Inches	A Bore MM	B CL Of Bearing To Face	C CL To CL Of Mounting	Bolt Hole Dia.	Part Number
1.181	30.0	0.710	5.875	0.594 X 0.906 Slot	N223802

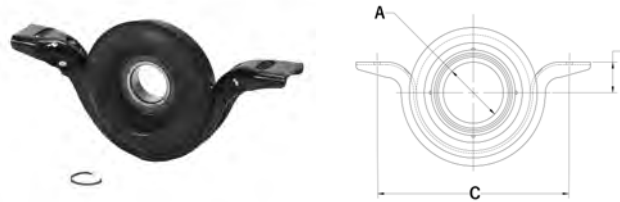

A Bore Inches	A Bore MM	B CL Of Bearing To Face	C CL To CL Of Mounting	Bolt Hole Dia.	Part Number
1.181	30.0	1.062	7.484	0.328 X 0.906 Slot	N214826

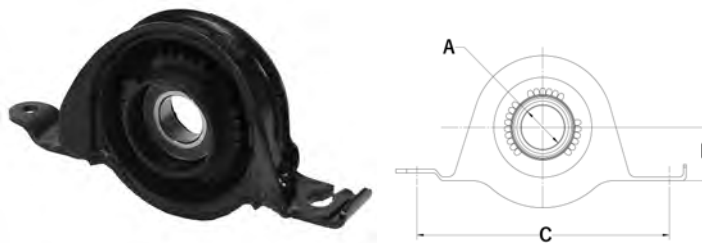

A Bore Inches	A Bore MM	B CL Of Bearing To Face	C CL To CL Of Mounting	Bolt Hole Dia.	Part Number
1.181	30.0	1.438	6.906	0.516 X 0.781 Slot	N229385

CENTER SUPPORT

DIMENSIONAL REFERENCE

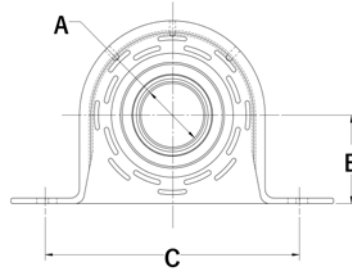

A Bore Inches	A Bore MM	B CL Of Bearing To Face	C CL To CL Of Mounting	Bolt Hole Dia.	Part Number
1.181	30.0	1.906	5.781	0.594 X 0.625 Slot	N211590-1X

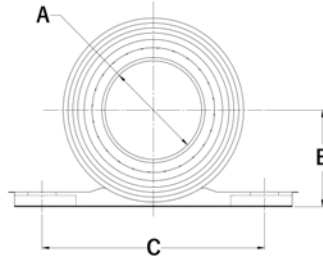

A Bore Inches	A Bore MM	B CL Of Bearing To Face	C CL To CL Of Mounting	Bolt Hole Dia.	Part Number
1.181	30.0	2.094	5.125	0.391 X 1.188 Slot	N217001

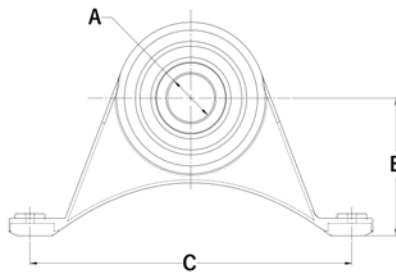

A Bore Inches	A Bore MM	B CL Of Bearing To Face	C CL To CL Of Mounting	Bolt Hole Dia.	Part Number
1.181	30.0	3.281 / 2.594	7.344	0.391 X 0.984 Slot	N211020-1X

CENTER SUPPORT



A Bore Inches	A Bore MM	B CL Of Bearing To Face	C CL To CL Of Mounting	Bolt Hole Dia.	Part Number
1.181	30.0	3.500	1.500	-	CN210527X

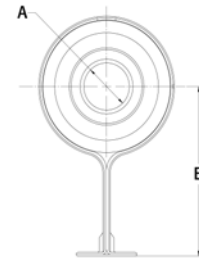

A Bore Inches	A Bore MM	B CL Of Bearing To Face	C CL To CL Of Mounting	Bolt Hole Dia.	Part Number
1.181	30.0	3.500	1500	-	N210527X

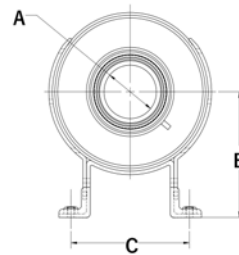

A Bore Inches	A Bore MM	B CL Of Bearing To Face	C CL To CL Of Mounting	Bolt Hole Dia.	Part Number
1.181	30.0	3.906	3.750	M12X1.750 Slot	N212187-1X

CENTER SUPPORT

DIMENSIONAL REFERENCE

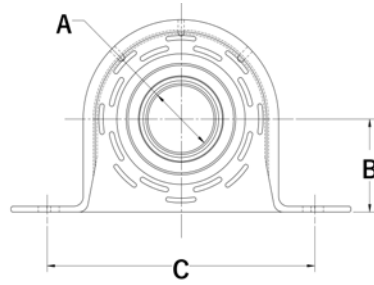

A Bore Inches	A Bore MM	B CL Of Bearing To Face	C CL To CL Of Mounting	Bolt Hole Dia.	Part Number
1.26	32.0	1.891	5.875	0.609 X 0.672 Slot	N211431X

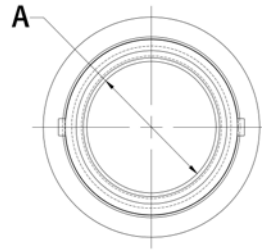

A Bore Inches	A Bore MM	B CL Of Bearing To Face	C CL To CL Of Mounting	Bolt Hole Dia.	Part Number
1.378	35.0	-	-	-	N212050X

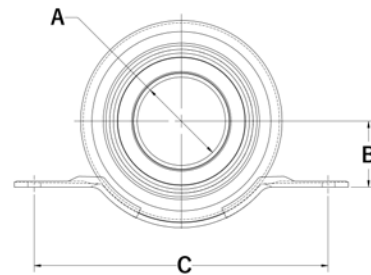

A Bore Inches	A Bore MM	B CL Of Bearing To Face	C CL To CL Of Mounting	Bolt Hole Dia.	Part Number
1.378	35.0	1.469	5.344	0.41 & 0.41 X 0.47	N217390

CENTER SUPPORT

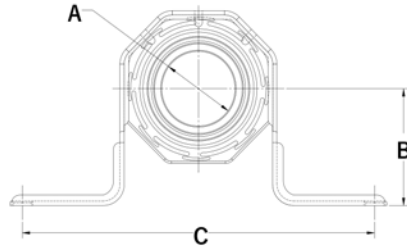

A Bore Inches	A Bore MM	B CL Of Bearing To Face	C CL To CL Of Mounting	Bolt Hole Dia.	Part Number
1.378	35.0	2.156	6.625	M10X1.5 Studs	N218102

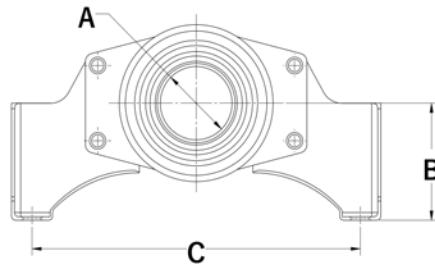

A Bore Inches	A Bore MM	B CL Of Bearing To Face	C CL To CL Of Mounting	Bolt Hole Dia.	Part Number
1.378	35.0	2.203	6.625	M10X1.5 Studs	N217020

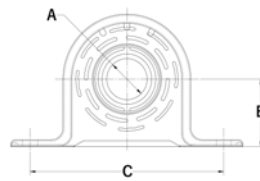

A Bore Inches	A Bore MM	B CL Of Bearing To Face	C CL To CL Of Mounting	Bolt Hole Dia.	Part Number
1.378	35.0	2.234	6.609	0.516 X 0.562 Slot	CN210088-1X

CENTER SUPPORT

DIMENSIONAL REFERENCE

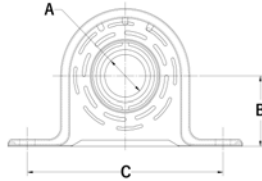

A Bore Inches	A Bore MM	B CL Of Bearing To Face	C CL To CL Of Mounting	Bolt Hole Dia.	Part Number
1.378	35.0	2.234	6.609	0.516 X 0.562 Slot	CN210090-1X

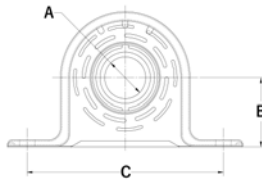

A Bore Inches	A Bore MM	B CL Of Bearing To Face	C CL To CL Of Mounting	Bolt Hole Dia.	Part Number
1.378	35.0	2.234	6.609	0.516 X 0.562 Slot	CN210367-1X

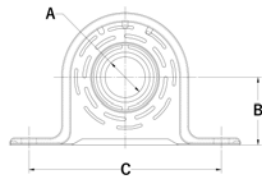

A Bore Inches	A Bore MM	B CL Of Bearing To Face	C CL To CL Of Mounting	Bolt Hole Dia.	Part Number
1.378	35.0	2.234	6.609	0.516 X 0.562 Slot	CN210370-1X

CENTER SUPPORT

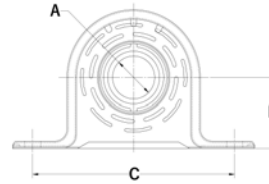

A Bore Inches	A Bore MM	B CL Of Bearing To Face	C CL To CL Of Mounting	Bolt Hole Dia.	Part Number
1.378	35.0	2.234	6.609	0.516 X 0.562 Slot	N210088-1X

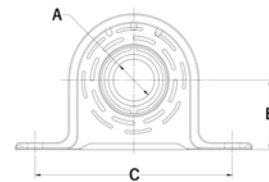

A Bore Inches	A Bore MM	B CL Of Bearing To Face	C CL To CL Of Mounting	Bolt Hole Dia.	Part Number
1.378	35.0	2.234	6.609	0.516 X 0.562 Slot	N210090-1X

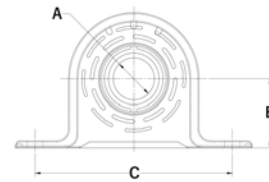

A Bore Inches	A Bore MM	B CL Of Bearing To Face	C CL To CL Of Mounting	Bolt Hole Dia.	Part Number
1.378	35.0	2.234	6.609	0.516 X 0.562 Slot	N210367-1X

CENTER SUPPORT

DIMENSIONAL REFERENCE

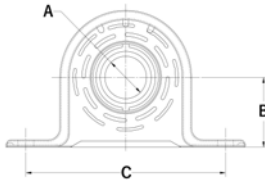

A Bore Inches	A Bore MM	B CL Of Bearing To Face	C CL To CL Of Mounting	Bolt Hole Dia.	Part Number
1.378	35.0	2.234	6.609	0.516 X 0.562 Slot	N210370-1X

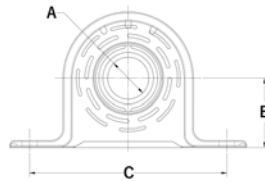

A Bore Inches	A Bore MM	B CL Of Bearing To Face	C CL To CL Of Mounting	Bolt Hole Dia.	Part Number
1.378	35.0	2.234	6.609	0.516 X 0.562 Slot	N211036-2X

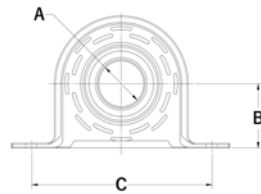

A Bore Inches	A Bore MM	B CL Of Bearing To Face	C CL To CL Of Mounting	Bolt Hole Dia.	Part Number
1.378	35.0	2.234	6.625	0.562 Dia.	N211139X

CENTER SUPPORT

CENTER SUPPORT

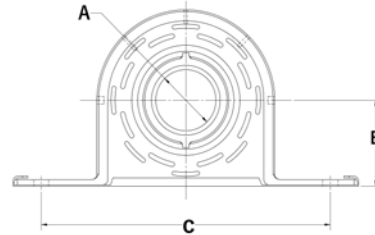

A Bore Inches	A Bore MM	B CL Of Bearing To Face	C CL To CL Of Mounting	Bolt Hole Dia.	Part Number
1.378	35.0	2.24	6.625	0.562 Dia.	N211187X

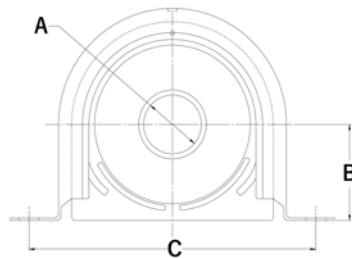

A Bore Inches	A Bore MM	B CL Of Bearing To Face	C CL To CL Of Mounting	Bolt Hole Dia.	Part Number
1.378	35.0	2.250	6.625	0.500 X 0.570 Slot	N211175X

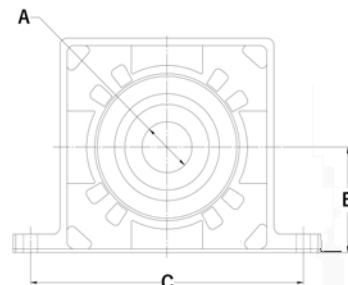

A Bore Inches	A Bore MM	B CL Of Bearing To Face	C CL To CL Of Mounting	Bolt Hole Dia.	Part Number
1.378	35.0	2.250	6.625	0.516 X 0.562 Slot	N217042

CENTER SUPPORT

DIMENSIONAL REFERENCE

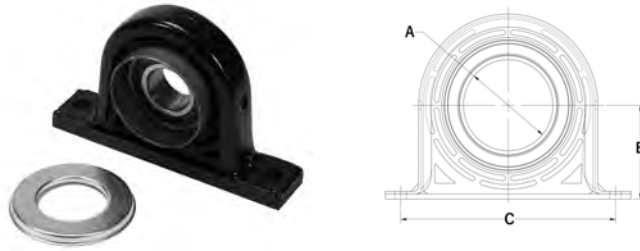

A Bore Inches	A Bore MM	B CL Of Bearing To Face	C CL To CL Of Mounting	Bolt Hole Dia.	Part Number
1.378	35.0	2.703	6.625	0.516 X 0.562 Slot	N211985X

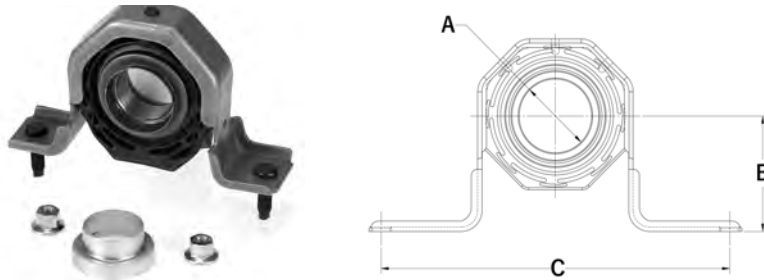

A Bore Inches	A Bore MM	B CL Of Bearing To Face	C CL To CL Of Mounting	Bolt Hole Dia.	Part Number
1.575	40.0	2.156	6.656	M10X1.5 Studs	N218099

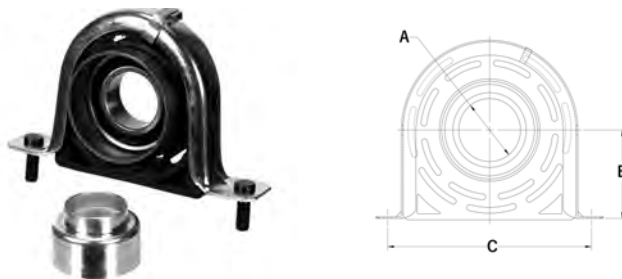

A Bore Inches	A Bore MM	B CL Of Bearing To Face	C CL To CL Of Mounting	Bolt Hole Dia.	Part Number
1.575	40.0	2.234	6.625	M10X1.5 Studs	N212028-1X

CENTER SUPPORT

CENTER SUPPORT

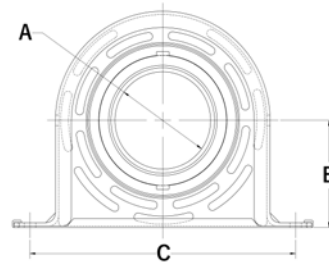

A Bore Inches	A Bore MM	B CL Of Bearing To Face	C CL To CL Of Mounting	Bolt Hole Dia.	Part Number
1.575	40.0	2.234	6.609	0.500 X 0.547 Slot	CN210866-1X

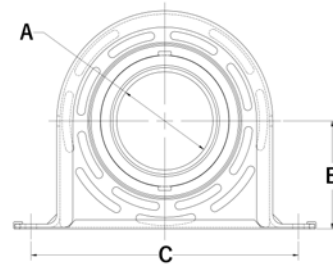

A Bore Inches	A Bore MM	B CL Of Bearing To Face	C CL To CL Of Mounting	Bolt Hole Dia.	Part Number
1.575	40.0	2.234	6.609	0.500 X 0.547 Slot	CN210873-1X

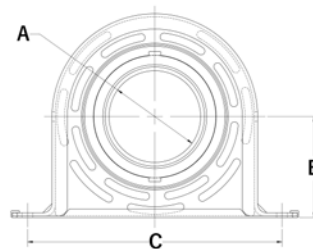

A Bore Inches	A Bore MM	B CL Of Bearing To Face	C CL To CL Of Mounting	Bolt Hole Dia.	Part Number
1.575	40.0	2.234	6.609	0.500 X 0.547 Slot	N210866-1X

CENTER SUPPORT

DIMENSIONAL REFERENCE

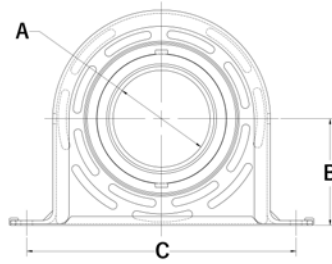

A Bore Inches	A Bore MM	B CL Of Bearing To Face	C CL To CL Of Mounting	Bolt Hole Dia.	Part Number
1.575	40.0	2.234	6.609	0.500 X 0.547 Slot	N210873-1X

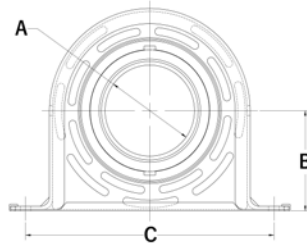

A Bore Inches	A Bore MM	B CL Of Bearing To Face	C CL To CL Of Mounting	Bolt Hole Dia.	Part Number
1.575	40.0	2.234	6.609	0.500 X 0.547 Slot	N211016X

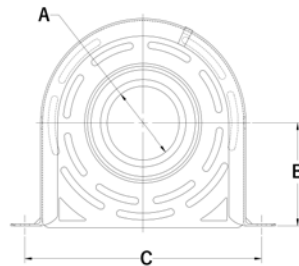

A Bore Inches	A Bore MM	B CL Of Bearing To Face	C CL To CL Of Mounting	Bolt Hole Dia.	Part Number
1.575	40.0	2.234	6.625	0.500 X 0.570 Slot	N235150

CENTER SUPPORT

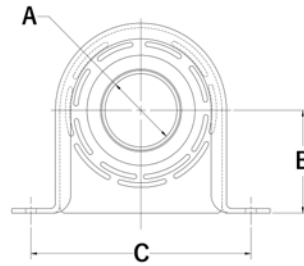

A Bore Inches	A Bore MM	B CL Of Bearing To Face	C CL To CL Of Mounting	Bolt Hole Dia.	Part Number
1.575	40.0	2.250	6.625	0.500 X 0.547 Slot	N211359X

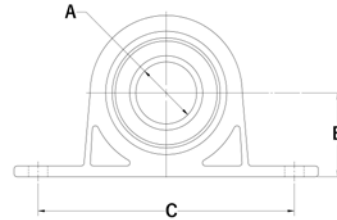

A Bore Inches	A Bore MM	B CL Of Bearing To Face	C CL To CL Of Mounting	Bolt Hole Dia.	Part Number
1.575	40.0	2.250	6.625	0.500 X 0.562 Slot	N214035X

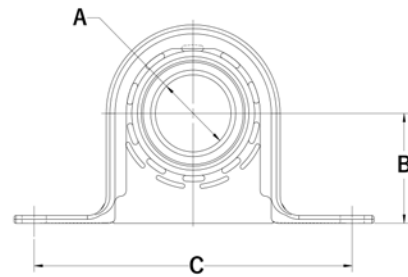

A Bore Inches	A Bore MM	B CL Of Bearing To Face	C CL To CL Of Mounting	Bolt Hole Dia.	Part Number
1.575	40.0	2.250	6.625	0.500 X 0.570 Slot	N211499X

CENTER SUPPORT

DIMENSIONAL REFERENCE

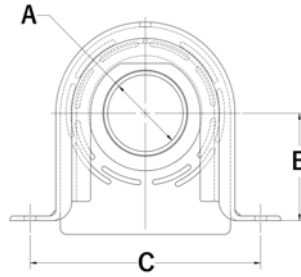

A Bore Inches	A Bore MM	B CL Of Bearing To Face	C CL To CL Of Mounting	Bolt Hole Dia.	Part Number
1.575	40.0	2.250	6.625	0.500 X 0.570 Slot	N212053-1X

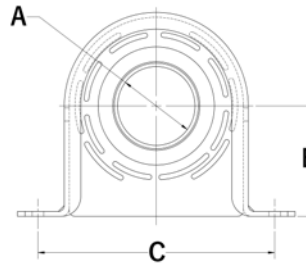

A Bore Inches	A Bore MM	B CL Of Bearing To Face	C CL To CL Of Mounting	Bolt Hole Dia.	Part Number
1.575	40.0	2.250	6.625	0.562 Dia.	N212093-1X

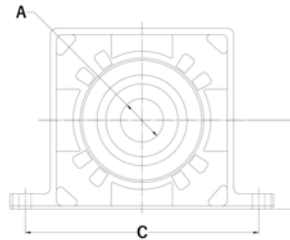

A Bore Inches	A Bore MM	B CL Of Bearing To Face	C CL To CL Of Mounting	Bolt Hole Dia.	Part Number
1.575	40.0	2.250	6.625	0.516 X 0.562 Slot	N217334

CENTER SUPPORT

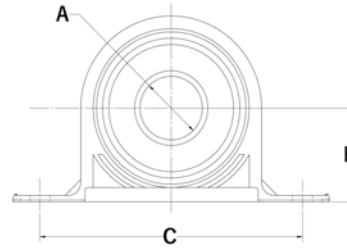

A Bore Inches	A Bore MM	B CL Of Bearing To Face	C CL To CL Of Mounting	Bolt Hole Dia.	Part Number
1.575	40.0	2.281	6.625	0.500 X 0.570 Slot	N235200

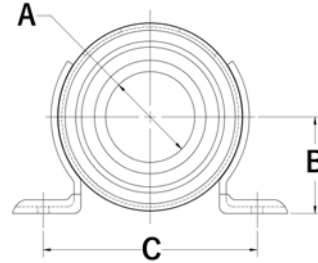

A Bore Inches	A Bore MM	B CL Of Bearing To Face	C CL To CL Of Mounting	Bolt Hole Dia.	Part Number
1.575	40.0	2.297	6.625	0.438 Dia.	N213075

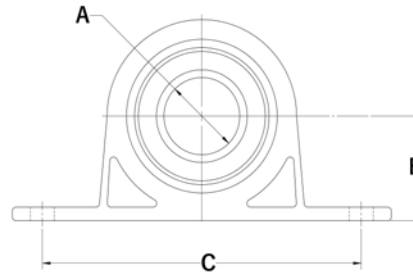

A Bore Inches	A Bore MM	B CL Of Bearing To Face	C CL To CL Of Mounting	Bolt Hole Dia.	Part Number
1.575	40.0	2.490	6.625	0.500 X 0.562 Slot	N214034X

CENTER SUPPORT

DIMENSIONAL REFERENCE

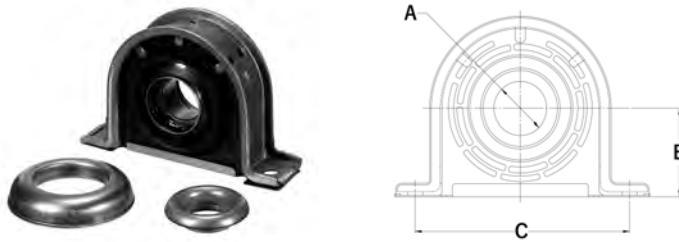

A Bore Inches	A Bore MM	B CL Of Bearing To Face	C CL To CL Of Mounting	Bolt Hole Dia.	Part Number
1.575	40.0	2.500	6.625	0.562 Dia.	CN210140-1X

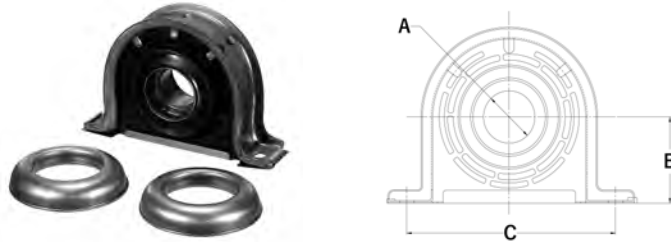

A Bore Inches	A Bore MM	B CL Of Bearing To Face	C CL To CL Of Mounting	Bolt Hole Dia.	Part Number
1.575	40.0	2.500	6.625	0.562 Dia.	CN210144-1X

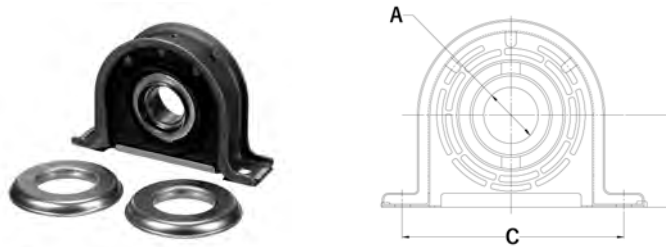

A Bore Inches	A Bore MM	B CL Of Bearing To Face	C CL To CL Of Mounting	Bolt Hole Dia.	Part Number
1.575	40.0	2.500	6.625	0.562 Dia.	CN210391-1X

CENTER SUPPORT

CENTER SUPPORT

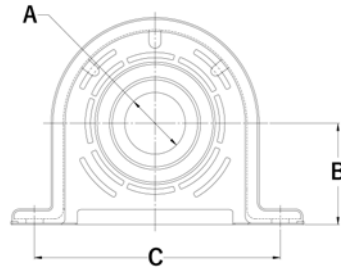

A Bore Inches	A Bore MM	B CL Of Bearing To Face	C CL To CL Of Mounting	Bolt Hole Dia.	Part Number
1.575	40.0	2.500	6.625	0.562 Dia.	CN210433-1X

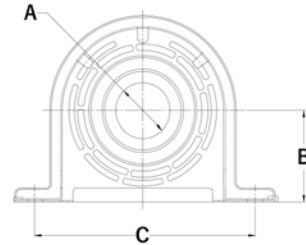

A Bore Inches	A Bore MM	B CL Of Bearing To Face	C CL To CL Of Mounting	Bolt Hole Dia.	Part Number
1.575	40.0	2.500	6.625	0.562 Dia.	N210140-1X

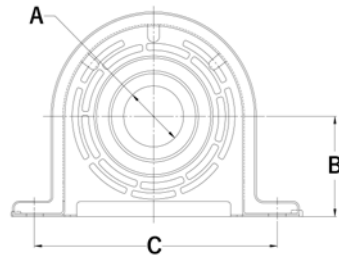

A Bore Inches	A Bore MM	B CL Of Bearing To Face	C CL To CL Of Mounting	Bolt Hole Dia.	Part Number
1.575	40.0	2.500	6.625	0.562 Dia.	N210144-1X

CENTER SUPPORT

DIMENSIONAL REFERENCE

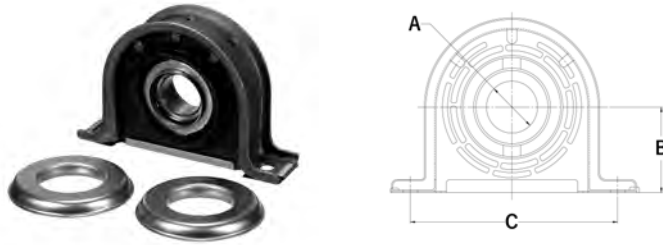

A Bore Inches	A Bore MM	B CL Of Bearing To Face	C CL To CL Of Mounting	Bolt Hole Dia.	Part Number
1.575	40.0	2.500	6.625	0.562 Dia.	N210391-1X

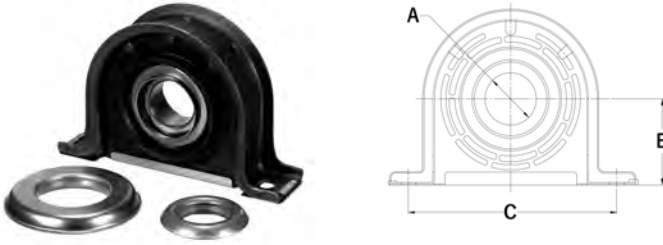

A Bore Inches	A Bore MM	B CL Of Bearing To Face	C CL To CL Of Mounting	Bolt Hole Dia.	Part Number
1.575	40.0	2.500	6.625	0.562 Dia.	N210433-1X

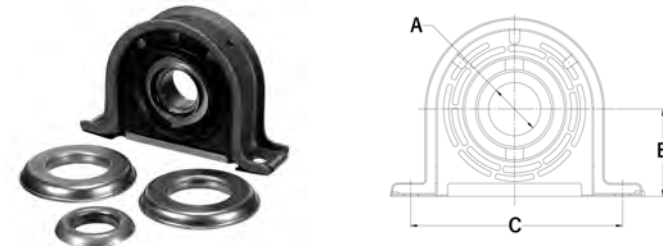

A Bore Inches	A Bore MM	B CL Of Bearing To Face	C CL To CL Of Mounting	Bolt Hole Dia.	Part Number
1.575	40.0	2.500	6.625	0.562 Dia.	N211037-1X

CENTER SUPPORT

CENTER SUPPORT

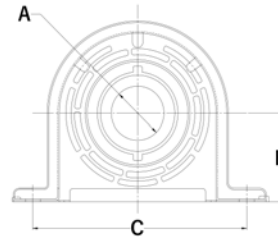

A Bore Inches	A Bore MM	B CL Of Bearing To Face	C CL To CL Of Mounting	Bolt Hole Dia.	Part Number
1.575	40.0	2.500	6.625	0.562 Dia.	N211098-1X

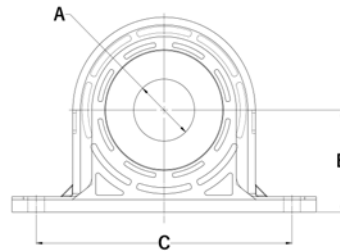

A Bore Inches	A Bore MM	B CL Of Bearing To Face	C CL To CL Of Mounting	Bolt Hole Dia.	Part Number
1.575	40.0	2.594	6.625	M10X1.5 Studs	N212032-1X

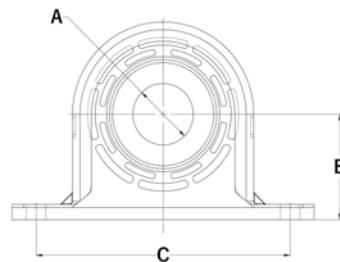

A Bore Inches	A Bore MM	B CL Of Bearing To Face	C CL To CL Of Mounting	Bolt Hole Dia.	Part Number
1.575	40.0	2.703	6.625	0.516 X 0.562 Slot	N211361-1X

CENTER SUPPORT

DIMENSIONAL REFERENCE

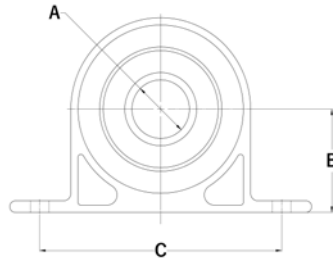

A Bore Inches	A Bore MM	B CL Of Bearing To Face	C CL To CL Of Mounting	Bolt Hole Dia.	Part Number
1.575	40.0	2.781	6.625	0.500 X 0.562 Slot	N214033X

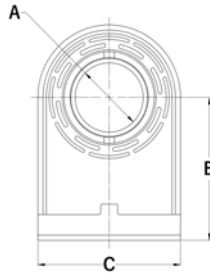

A Bore Inches	A Bore MM	B CL Of Bearing To Face	C CL To CL Of Mounting	Bolt Hole Dia.	Part Number
1.575	40.0	3.250	3.391	0.438-14 Nut	N211848-1X

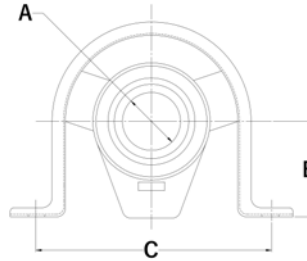

A Bore Inches	A Bore MM	B CL Of Bearing To Face	C CL To CL Of Mounting	Bolt Hole Dia.	Part Number
1.772	45.0	2.641	7.641	0.531 X 1.188 Slot	N214574

CENTER SUPPORT

CENTER SUPPORT

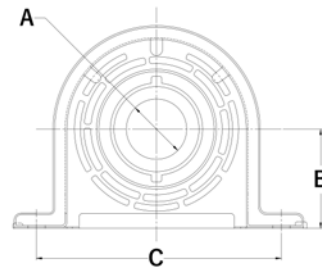

A Bore Inches	A Bore MM	B CL Of Bearing To Face	C CL To CL Of Mounting	Bolt Hole Dia.	Part Number
1.772	45.0	2.719	7.625	0.562 Dia.	CN210084-2X

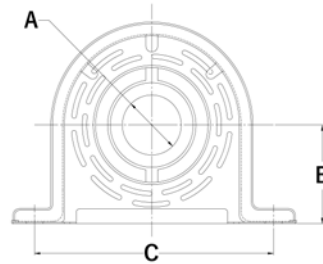

A Bore Inches	A Bore MM	B CL Of Bearing To Face	C CL To CL Of Mounting	Bolt Hole Dia.	Part Number
1.772	45.0	2.719	7.625	0.562 Dia.	CN210207-1X

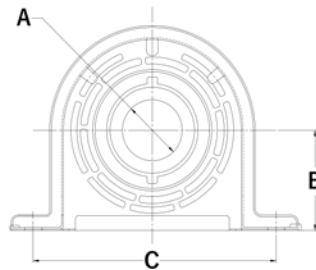

A Bore Inches	A Bore MM	B CL Of Bearing To Face	C CL To CL Of Mounting	Bolt Hole Dia.	Part Number
1.772	45.0	2.719	7.625	0.562 Dia.	CN210969X
1.772	45.0	2.719	7.625	0.562 Dia.	N210084-2X

CENTER SUPPORT

DIMENSIONAL REFERENCE

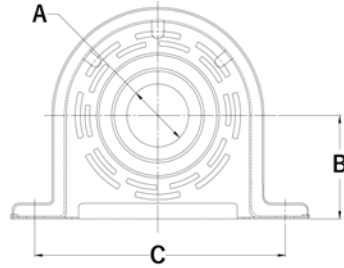

A Bore Inches	A Bore MM	B CL Of Bearing To Face	C CL To CL Of Mounting	Bolt Hole Dia.	Part Number
1.772	45.0	2.719	7.625	0.562 Dia.	N210130-1X

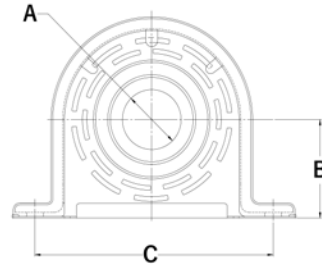

A Bore Inches	A Bore MM	B CL Of Bearing To Face	C CL To CL Of Mounting	Bolt Hole Dia.	Part Number
1.772	45.0	2.719	7.625	0.562 Dia.	N210207-1X

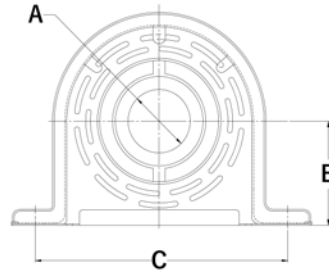

A Bore Inches	A Bore MM	B CL Of Bearing To Face	C CL To CL Of Mounting	Bolt Hole Dia.	Part Number
1.772	45.0	2.719	7.625	0.562 Dia.	N210969X

CENTER SUPPORT

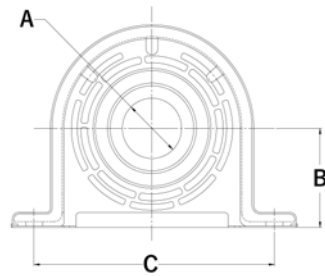

A Bore Inches	A Bore MM	B CL Of Bearing To Face	C CL To CL Of Mounting	Bolt Hole Dia.	Part Number
1.772	45.0	2.719	7.625	0.562 Dia.	N211172-1X

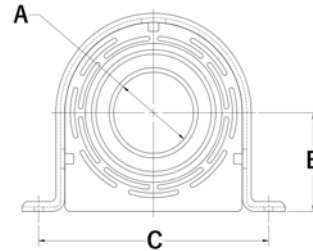

A Bore Inches	A Bore MM	B CL Of Bearing To Face	C CL To CL Of Mounting	Bolt Hole Dia.	Part Number
1.772	45.0	2.767	7.625	0.516 X 0.562 Slot	N212134-1X

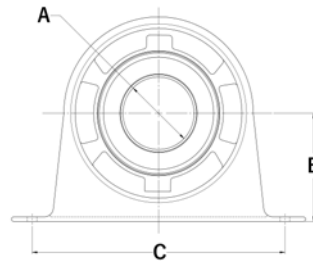

A Bore Inches	A Bore MM	B CL Of Bearing To Face	C CL To CL Of Mounting	Bolt Hole Dia.	Part Number
1.85	47.0	2.703	7.641	0.516 X 1.203 Slot	N214734

CENTER SUPPORT

DIMENSIONAL REFERENCE

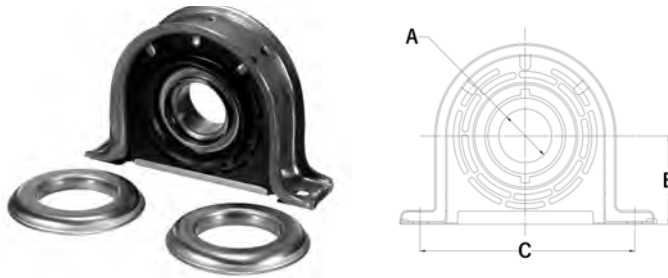

A Bore Inches	A Bore MM	B CL Of Bearing To Face	C CL To CL Of Mounting	Bolt Hole Dia.	Part Number
1.968	50.0	2.797	7.625	0.516 X 0.625 Slot	CN210121-1X

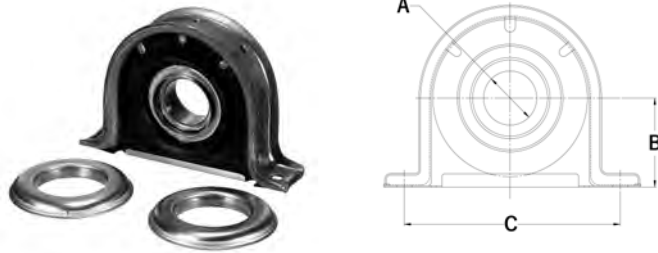

A Bore Inches	A Bore MM	B CL Of Bearing To Face	C CL To CL Of Mounting	Bolt Hole Dia.	Part Number
1.968	50.0	2.797	7.625	0.516 X 0.625 Slot	CN210881-1X

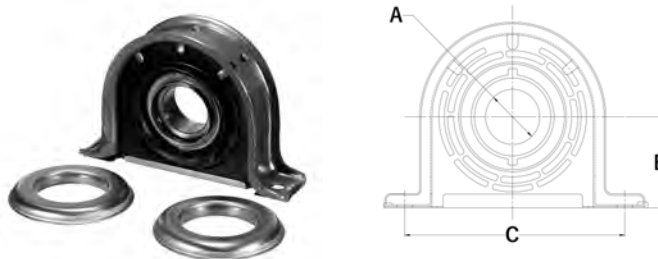

A Bore Inches	A Bore MM	B CL Of Bearing To Face	C CL To CL Of Mounting	Bolt Hole Dia.	Part Number
1.968	50.0	2.797	7.625	0.516 X 0.625 Slot	N210121-1X

CENTER SUPPORT

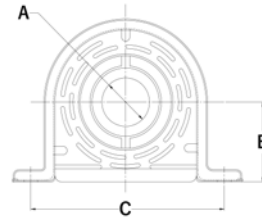

A Bore Inches	A Bore MM	B CL Of Bearing To Face	C CL To CL Of Mounting	Bolt Hole Dia.	Part Number
1.968	50.0	2.797	7.625	0.516 X 0.625 Slot	N210121-1XSA

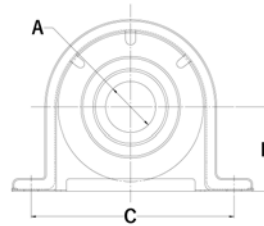

A Bore Inches	A Bore MM	B CL Of Bearing To Face	C CL To CL Of Mounting	Bolt Hole Dia.	Part Number
1.968	50.0	2.797	7.625	0.516 X 0.625 Slot	N210881-1X

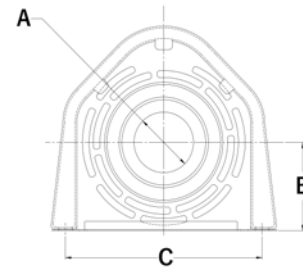

A Bore Inches	A Bore MM	B CL Of Bearing To Face	C CL To CL Of Mounting	Bolt Hole Dia.	Part Number
2.362	60.0	3.375	8.625	0.625 X 0.750 Slot	CN210661-1X

CENTER SUPPORT

DIMENSIONAL REFERENCE

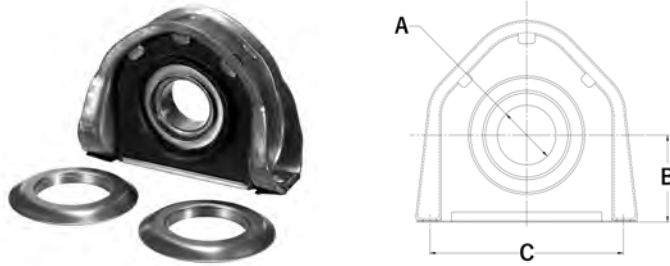

A Bore Inches	A Bore MM	B CL Of Bearing To Face	C CL To CL Of Mounting	Bolt Hole Dia.	Part Number
2.362	60.0	3.375	8.625	0.625 X 0.750 Slot	CN210875-1X

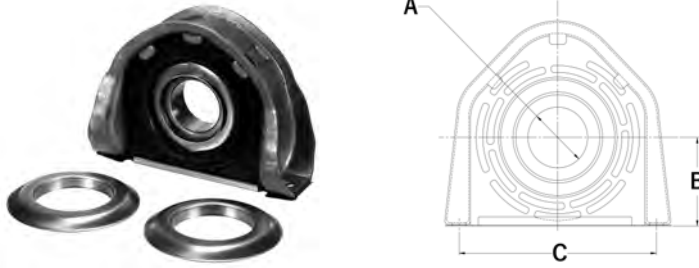

A Bore Inches	A Bore MM	B CL Of Bearing To Face	C CL To CL Of Mounting	Bolt Hole Dia.	Part Number
2.362	60.0	3.375	8.625	0.625 X 0.750 Slot	N210661-1X

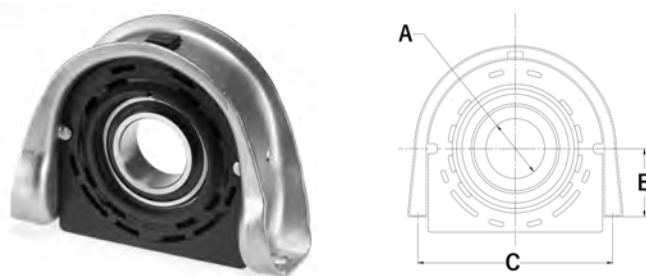

A Bore Inches	A Bore MM	B CL Of Bearing To Face	C CL To CL Of Mounting	Bolt Hole Dia.	Part Number
2.362	60.0	3.375	8.625	0.625 X 0.750 Slot	N210661-1XSA

CENTER SUPPORT

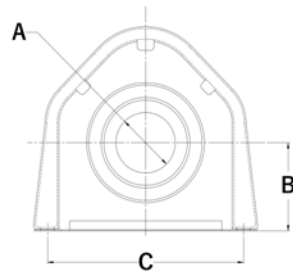

A Bore Inches	A Bore MM	B CL Of Bearing To Face	C CL To CL Of Mounting	Bolt Hole Dia.	Part Number
2.362	60.0	3.375	8.625	0.625 X 0.750 Slot	N210875-1X

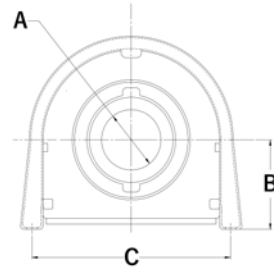

A Bore Inches	A Bore MM	B CL Of Bearing To Face	C CL To CL Of Mounting	Bolt Hole Dia.	Part Number
2.362	60.0	3.375	8.625	0.625 X 0.750 Slot	N210875-1XSA

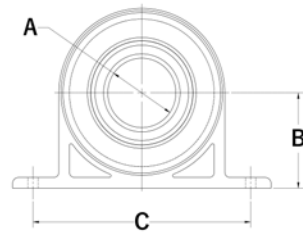

A Bore Inches	A Bore MM	B CL Of Bearing To Face	C CL To CL Of Mounting	Bolt Hole Dia.	Part Number
1.575	40.0	2.516	6.625	0.438 X 1.062 Slot	N215263

CENTER SUPPORT

DIMENSIONAL REFERENCE

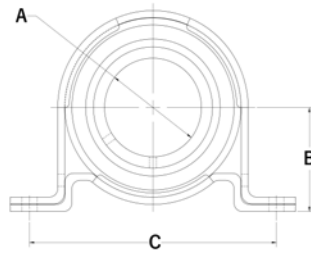

A Bore Inches	A Bore MM	B CL Of Bearing To Face	C CL To CL Of Mounting	Bolt Hole Dia.	Part Number
1.181	-	1.358	3.750	0.562 Dia.	NOE-08-0224-A

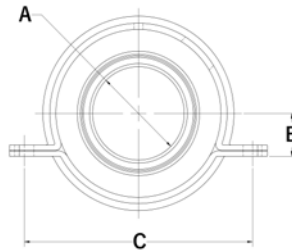

A Bore Inches	A Bore MM	B CL Of Bearing To Face	C CL To CL Of Mounting	Bolt Hole Dia.	Part Number
1.181	-	0.710	5.866	0.906 x 0.594 Slot	NOE-08-3806-A

NOTES



THE DRIVELINE EXPERTS

Aluminum Components

SECTION
12

SUB SECTION

Balance Weights

Tubing

Driveshaft Assemblies

Tube Yokes

Yoke Shaft Assemblies

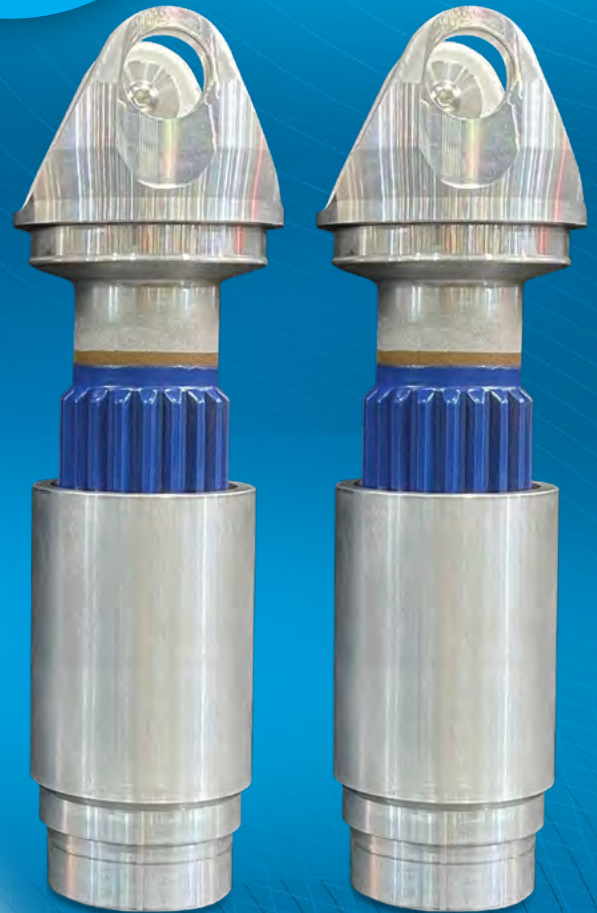

**Manufacturing Driveline Solutions®
in the USA Since 1921.**

NeapcoAftermarket.com

©Neapco LLC 2023

ALUMINIUM COMPONENTS

BALANCE WEIGHTS

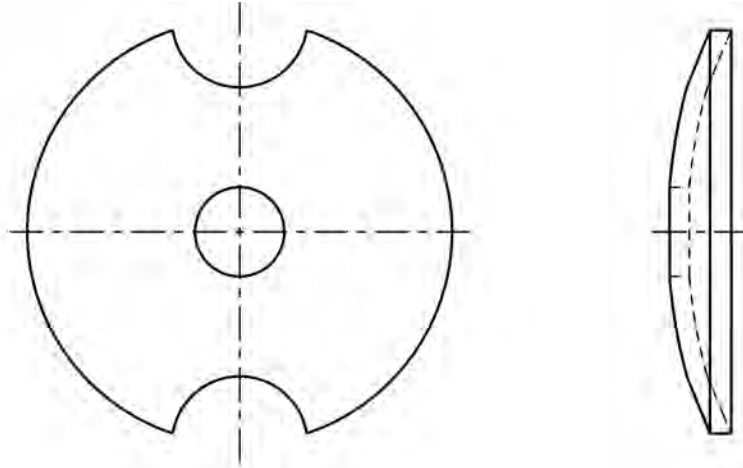

Unit Weight Grams	Unit Weight Ounces	Quantity Per Box	Thickness	Width	Tube Dia.	Part Number
2.6	0.092	50	0.075	1.250	3.500 AND 4.000	DLWA-41
2.6	0.092	50	0.075	0.710	3.000	DLWA-31
2.6	0.092	50	0.075	1.250	5.000	DLWA-51
4.3	0.152	50	0.075	1.250	3.500 AND 4.000	DLWA-42
4.3	0.152	50	0.075	1.120	3.000	DLWA-32
4.3	0.152	50	0.075	1.250	5.000	DLWA-52
5.5	0.194	50	0.075	1.410	3.000	DLWA-33
5.5	0.194	50	0.075	1.250	3.500 AND 4.000	DLWA-43
5.5	0.194	50	0.075	1.250	5.000	DLWA-53
8.0	0.282	50	0.075	1.980	3.000	DLWA-34
8.0	0.282	50	0.075	1.250	3.500 AND 4.000	DLWA-44
8.0	0.282	50	0.075	1.250	5.000	DLWA-54
9.0	0.317	50	0.250	0.760	3.000	DLWA-35
9.0	0.317	50	0.250	1.250	3.500 AND 4.000	DLWA-45
9.0	0.317	50	0.250	1.250	5.000	DLWA-55
10.6	0.374	50	0.250	1.250	5.000	DLWA-56
10.6	0.374	50	0.250	0.900	3.000	DLWA-36
10.6	0.374	50	0.250	1.250	3.500 AND 4.000	DLWA-46
20.0	0.705	25	0.250	1.250	5.000	DLWA-57
20.0	0.705	50	0.250	1.250	3.500 AND 4.000	DLWA-47
20.0	0.705	50	0.250	1.570	3.000	DLWA-37

ALUMINIUM COMPONENTS

TUBING

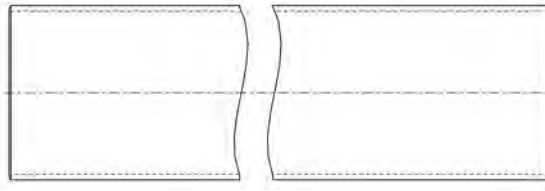
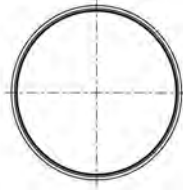

Tubing Type	Inside Dia.	Length	Outside Dia.	Wall Thickness	Part Number
Seamless	2.750	54.0	3.000	0.125	TAL-300-125-54
Seamless	2.750	54.0	3.000	0.125	TAL-300-125-54B58
Seamless	2.750	72.0	3.000	0.125	TAL-300-125-72
Seamless	2.750	72.0	3.000	0.125	TAL-300-125-72B58
Seamless	3.272	37.7	3.500	0.114	TAL-350-114-36
Seamless	3.272	62.0	3.500	0.114	TAL-350-114-62
Seamless	3.750	36.0	3.500	0.125	TAL-350-125-36
Seamless	3.250	54.0	3.500	0.125	TAL-350-125-54
Seamless	3.250	54.0	3.500	0.125	TAL-350-125-54B57
Seamless	3.250	72.0	3.500	0.125	TAL-350-125-72
Seamless	3.250	72.0	3.500	0.125	TAL-350-125-72B57
Seamless	3.830	54.0	4.000	0.083	TAL-400-083-54
Seamless	3.830	54.0	4.000	0.083	TAL-400-083-54B60
Seamless	3.834	72.0	4.000	0.083	TAL-400-083-72
Seamless	3.830	72.0	4.000	0.083	TAL-400-083-72B60
Seamless	3.826	62.0	4.000	0.087	TAL-400-087-62
Seamless	3.750	54.0	4.000	0.125	TAL-400-125-54
Seamless	3.750	54.0	4.000	0.125	TAL-400-125-54B60
Seamless	3.750	72.0	4.000	0.125	TAL-400-125-72
Seamless	3.750	72.0	4.000	0.125	TAL-400-125-72B60
Seamless	4.750	54.0	5.000	0.125	TAL-500-125-54
Seamless	4.750	54.0	5.000	0.125	TAL-500-125-54B59
Seamless	4.750	72.0	5.000	0.125	TAL-500-125-72
Seamless	4.750	72.0	5.000	0.125	TAL-500-125-72B59
Seamless	4.750	80.0	5.000	0.125	TAL-500-125-80
Seamless	4.750	80.0	5.000	0.125	TAL-500-125-80B59

ALUMINIUM COMPONENTS

DRIVESHAFT ASSEMBLIES

DL Series	Driveshaft Style	CL To CL Max. Extended Length	CL To Point Of Weld	Tubing Dia. And Wall	Part Number
1330 Series A-3.875 B-1.063					
1330	Unwelded	79.80	3.906	3.500 X .125	A133-7200-3.5HD
1330	Unwelded	87.00	3.454	5.000 X .125	A133-8000-5
1350 Series A-3.875 B-1.188					
1350	Unwelded	79.80	3.906	3.500 X .125	A135-7200-3.5HD
1350	Unwelded	87.00	3.454	5.000 X .125	A135-8000-5
1410 Series A-4.438 B-1.188					
1410	Unwelded	73.00	3.906	4.000 X .087	A141-6500-4
1410	Unwelded	87.00	3.454	5.000 X .125	A141-8000-5
1480 Series A-4.438 B-1.375					
1480	Unwelded	87.00	3.454	5.000 X .125	A148-8000-5

TUBE YOKES

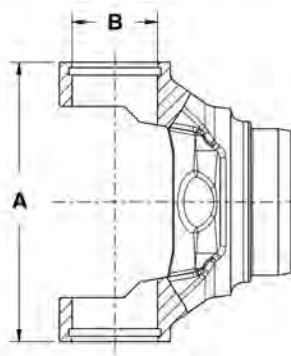

DL Series	Butt Dia.	CL To Point Of Weld	Tubing Dia. And Wall	Type Of Butt	Part Number
1330 Series A-3.875 B-1.063					
1330	3.843	3.901	4.000 X .083	***	A33-28-4008
1330	3.843	3.901	4.000 X .083	***	A33-28-4009
1350 Series A-3.875 B-1.188					
1350	3.843	3.901	4.000 X .083	***	A35-28-4008
1310 Series A-3.469 B-1.063					
1310	2.766	2.031	3.000 X .125	HO	A31-28-3012
1310	3.250	2.031	3.500 X .125	HO	A31-28-3512

ALUMINIUM COMPONENTS

TUBE YOKES (Cont'd)

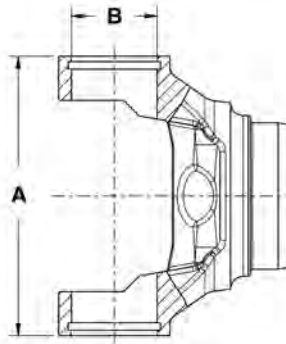

DL Series	Butt Dia.	CL To Point Of Weld	Tubing Dia. And Wall	Type Of Butt	Part Number
1330 Series		A-3.875 B-1.063			
1330	2.766	2.500	3.000 X.125	HO	A33-28-3012
1330	3.344	3.906	3.500 X.114	HO	A33-28-3511
1330	3.250	2.156	3.500 X.125	HO	A33-28-3512
1330	3.760	3.902	4.000 X.125	HO	A33-28-4012
1330	4.750	3.454	5.000 X.125	HO	A33-28-5012
1350 Series		A-3.875 B-1.188			
1350	3.344	3.906	3.500 X.114	HO	A35-28-3511
1350	3.250	1.750	3.500 X.125	HO	A35-28-3512
1350	3.760	3.902	4.000 X.125	HO	A35-28-4012
1350	4.750	3.454	5.000 X.125	HO	A35-28-5012
1410 Series		A-4.438 B-1.188			
1410	3.843	3.902	4.083	HO	A41-28-4008
1410	3.844	3.906	4.000 X.087	HO	A41-28-4009
1410	3.760	3.902	4.000 X.125	HO	A41-28-4012
1410	4.750	3.454	5.000 X.125	HO	A41-28-5012
1480 Series		A-4.438 B-1.375			
1480	4.750	3.454	5.000 X.125	HO	A48-28-5012

ALUMINIUM COMPONENTS

YOKE SHAFT ASSEMBLIES

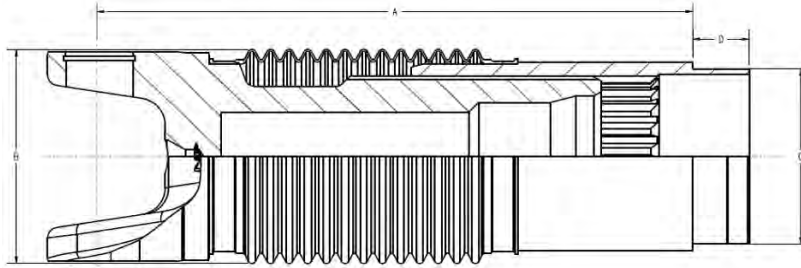

DL Series	Aluminum Tube OD and Wall	A Max Extended Length	A Min Compressed Length	A Recommended Boot Installation	B Boot Dia.	C Butt Dia.	D Butt Depth	Spline/Number Teeth	Part Number
1310 Series					A-3.469	B-1.063			
1310	3.000 x .125	11.500	7.500	10.500	4.000	2.758	1.000	2.500-19	N2-85-3130-AP
1310	3.500 x .125	11.400	7.400	10.400	4.000	3.258	1.000	3.000-23	N2-85-3135-AP
1350 Series					A-3.875	B-1.188			
1350	3.000 x .125	11.620	7.620	10.620	4.000	2.758	1.000	2.500-19	N3-85-3530-AP
1350	3.500 x .125	11.600	7.600	10.600	4.000	3.258	1.000	3.000-23	N3-85-3535-AP
1350	4.000 x .125	11.600	7.600	10.600	4.000	3.758	1.000	3.000-23	N3-85-3540-AP
1410 Series					A-4.438	B-1.188			
1410	4.000 x .125	13.320	7.800	12.320	5.000	3.758	1.000	3.500-27	N3-85-4140-AP
1480 Series					A-4.438	B-1.375			
1480	4.000 x .125	13.320	7.800	12.320	5.000	3.758	1.000	3.500-27	N3-85-4840-AP
1480	5.000 x .125	13.320	7.800	12.320	5.900	4.758	1.000	4.000-31	N3-85-4850-AP
1550 Series					A-5.250	B-1.375			
1550	5.000 x .125	13.710	8.200	12.710	5.900	4.758	1.000	4.000-31	N4-85-5550-AP

ALUMINIUM COMPONENTS

Notes

ALUMINIUM COMPONENTS



THE DRIVELINE EXPERTS

Wing Bearing Driveline Products

SECTION
13

SUB SECTION

- End Yoke
- Slip Yoke
- Stub Shaft
- Driveshaft Stub Shaft
- Tube Weld Yoke
- Yoke Shaft



**Manufacturing Driveline Solutions®
in the USA Since 1921.**

NeapcoAftermarket.com

WING BEARING

END YOKE

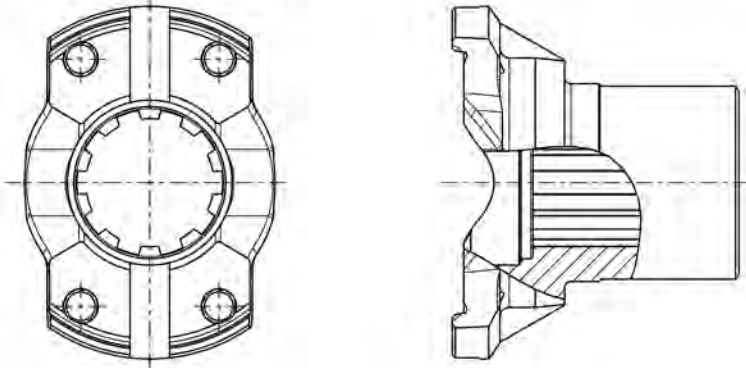

DL Series	Bore Type	Spline/Number Teeth	Face To End	Hole/ Thread Size	Hub Dia.	Length Thru Hole	Part Number
7C							
7C	Splined	1.750-10	3.438	0.470	2.375	2.188	10508J

SLIP YOKE

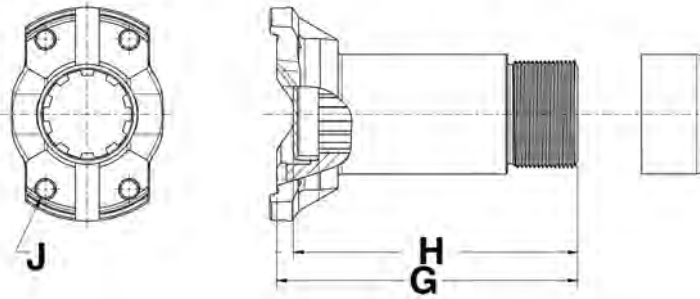

DL Series	Spline/ Number Teeth	G Overall Length	H Length To Dust Cap	J Hole/ Thread Size	Part Number
5C					
5C	1.560-16	5.625	4.500	3/8-24	5-67747
5C	1.500-10	5.375	N/A	3/8-24	6-5000
6C					
6C	1.750-10	5.625	4.375	3/8-24	6-6000
6C	1.750-16	9.500	8.375	3/8-24	6-6047
6C	1.750-16	6.125	4.875	3/8-24	6-6163
6C	1.750-16	8.875	7.625	3/8-24	6-67781

SLIP YOKE (Cont'd)

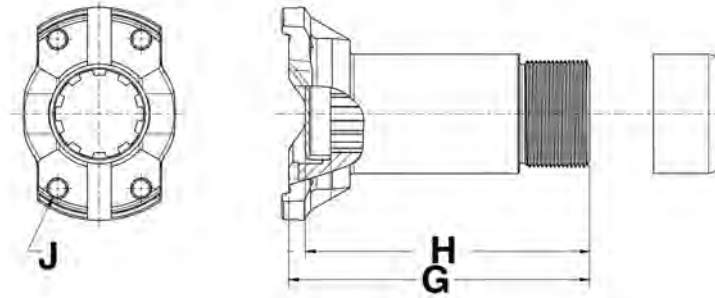

DL Series	Spline/ Number Teeth	G Overall Length	H Length To Dust Cap	J Hole/ Thread Size	Part Number
7C					
7C	2.000-16	7.062	6.062	1/2-20	6-67820
7C	2.000-10	7.062	6.062	1/2-20	6-7000
7C	2.000-10	9.125	8.125	0.469	6-7039
8C					
8C	2.500-16	8.625	7.500	1/2-20	8-78503
8.5C					
8.5C	2.500-16	8.625	7.375	1/2-20	85-67843
9C					
9C	3.000-16	9.625	8.565	1/2-20	9-67847

STUB SHAFT

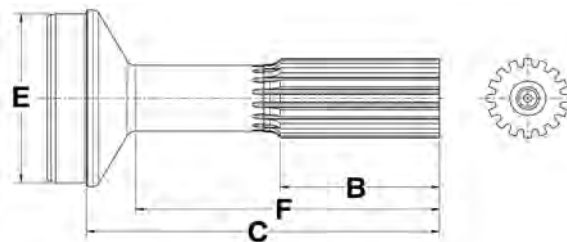

Spline/ Number Teeth	Tubing Dia. And Wall	B Length Of Spline	C End Of Spline To Weld	E Butt Dia.	F End Of Spline To Radius	Part Num- ber
1.750-16	3.500 X .095	3.000	9.625	3.312	8.750	17072J
1.500-10	2.500 X .095	3.000	6.750	2.312	6.047	3545J
1.750-10	3.000 X .095	3.000	7.000	2.812	6.281	3670J
1.562-16	2.500 X .095	3.000	6.375	2.281	5.562	5-61729

WING BEARING

STUB SHAFT (Cont'd)

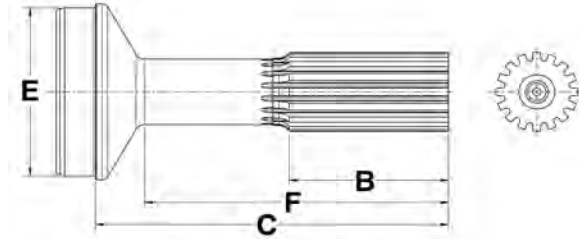

Spline/ Number Teeth	Tubing Dia. And Wall	B Length Of Spline	C End Of Spline To Weld	E Butt Dia.	F End Of Spline To Radius	Part Num- ber
1.750-16	3.000 X .095	3.000	7.000	2.812	6.281	6-61725
1.750-16	3.000 X .095	3.000	9.750	2.812	8.828	6-61747
2.000-16	3.500 X .120	3.875	8.500	3.266	7.438	7-61726
2.000-16	3.500 X .120	3.734	11.625	3.656	10.866	7-70825
2.500-16	4.000 X .187	4.500	10.000	3.625	8.812	8-61737
2.500-16	4.000 X .134	4.000	9.250	3.734	8.250	85-40541
3.000-16	4.500 X .250	5.375	11.188	4.000	9.656	9-61716
1.750-10	3.500 X .095	3.000	7.125	3.312	6.875	9146J
2.000-10	3.500 X .095	7.125	9.375	3.312	8.406	9276J
2.000-10	3.500 X .095	4.000	8.500	3.312	7.625	9281J

DRIVESHAFT STUB SHAFT

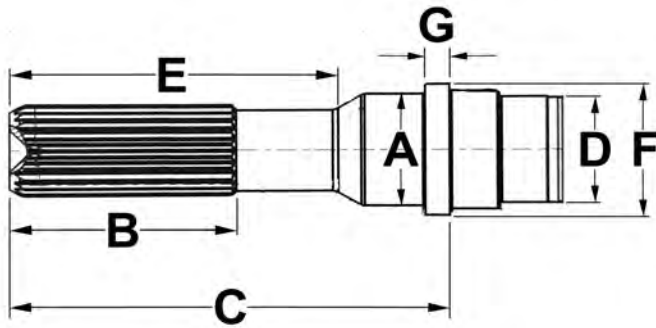

Spline/Number Teeth	Tubing Dia. And Wall	A Bearing Dia.	B Length Of Spline	C End Of Spline To Weld	D Butt Dia.	E End Of Spline To Radius	F Shoulder Dia.	G Length Of Shoulder	Part Number
0.958-22	1.259-.078	1.188	2.250	4.984	1.109	4.234	1.375	0.625	NOE-40-2531-A
0.958-22	1.259-.078	1.188	2.250	6.016	1.109	5.266	1.375	1.562	NOE-40-2539-A

WING BEARING

DRIVESHAFT STUB SHAFT (Cont'd)

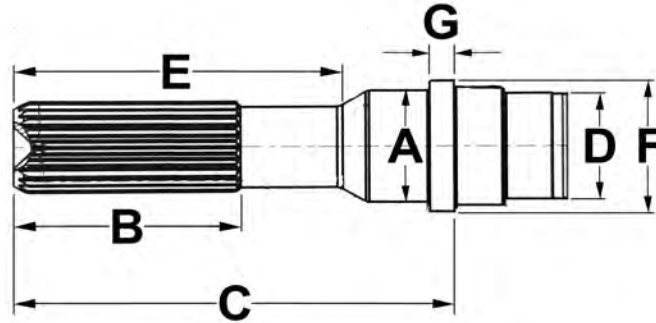

Spline/Number Teeth	Tubing Dia. And Wall	A Bearing Dia.	B Length Of Spline	C End Of Spline To Weld	D Butt Dia.	E End Of Spline To Radius	F Shoulder Dia.	G Length Of Shoulder	Part Number
0.958-22	1.259-.078	1.188	2.250	5.719	1.109	4.969	1.375	1.250	NOE-40-2541-A
0.958-22	1.625-.065	1.188	2.250	5.000	1.500	4.250	1.750	0.625	NOE-40-2543-A
0.958-22	1.259-.078	1.171	1.250	4.656	1.109	0.500	1.250	0.406	NOE-40-3512-A

WING BEARING

TUBE WELD YOKE

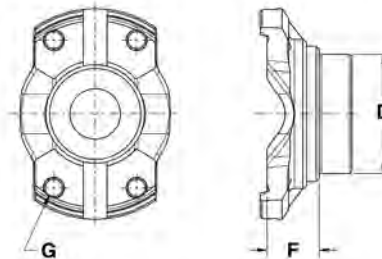

DL Series	Tubing Dia. And Wall	D Butt Dia.	F Face To Weld Point	G Hole/ Thread Size	Part Number
5C					
5C	2.500 X.095	2.312	1.120	3/8-24	5-65119
5C	2.500 X.109	2.281	1.120	0.410	5-65138
5C	2.500 X.109	2.281	1.120	3/8-24	5-65188

WING BEARING

TUBE WELD YOKE (Cont'd)

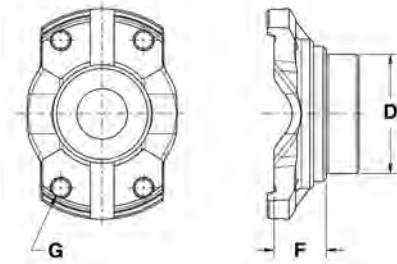

DL Series	Tubing Dia. And Wall	D Butt Dia.	F Face To Weld Point	G Hole/ Thread Size	Part Number
6C					
6C	3.000 X.095	2.812	1.875	0.410	6-65122
6C	3.500 X.095	3.312	1.875	3/8-24	6-65180
6C	3.000 X.095	2.812	1.875	3/8-24	6-65182
7C					
7C	3.500 X.095	3.312	2.125	1/2-20	7-65172
7C	3.500 X.120	3.266	2.125	1/2-20	7-65230
8C					
8C	4.000 X.187	3.625	2.688	1/2-20	8-65262
8.5C					
8.5C	4.000 X.134	3.750	2.625	1/2-20	85-6011
8.5C	4.000 X.187	3.625	2.125	1/2-20	85-74020
9C					
9C	4.500 X.250	4.094	2.500	1/2-20	9-65288

WING BEARING

YOKE SHAFT

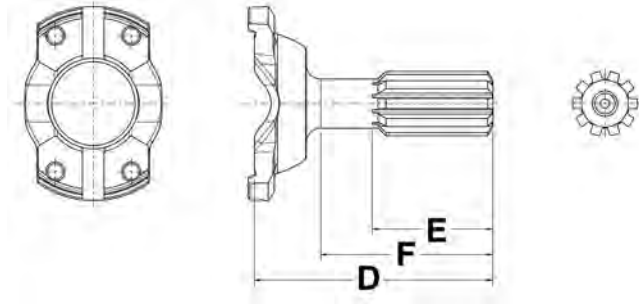

DL Series	Spline/Number Teeth	D Overall Length	E Length Of Spline	F End Of Spline To Radius	Part Number
7C					
7C	2.000-10	7.000	2.938	5.250	5505J

WING BEARING

WING BEARING

Notes



THE DRIVELINE EXPERTS

General Information

SECTION
14

SUB SECTION

- Universal Joints
- Driveline Components
- Driveline Fabrication
- Aluminum Components
- PTO Components
- Trouble Shooting Guide
- Glossary



**Manufacturing Driveline Solutions®
in the USA Since 1921.**

NeapcoAftermarket.com

GENERAL INFORMATION

Neapco Driveline Component Part Numbering System

EXAMPLE: N6-3-2651KX

<u>Neapco Series ID</u>	<u>Description</u>	<u>Part Number</u>	<u>Additional Items</u>
Ex: N6	3	2651	KX
1710 Series	Slip Yoke	Part No.	Dust Cap

SERIES ID NO	SERIES
N10	1000
N2	1310
	1330
	1350
N3	1410
	1480
	3R or S44
N3R	
N4	1550
N5	1610
N6	1710
N6.3	1760
N6.5	1810
N729	7290
N170	SPL170*
N250	SPL250*
N350	SPL350*

* SPL - Spicer® Life Series driveshafts is a registered trademark of Dana Limited.

GENERAL INFORMATION

Typical Methods Of Universal Joint Lock-up

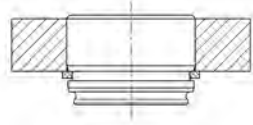

INSIDE

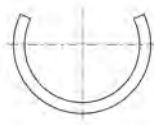

OUTSIDE

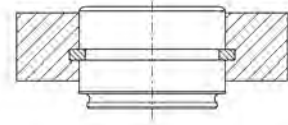
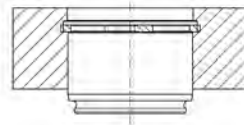

PLASTIC INJECTION



U - BOLT

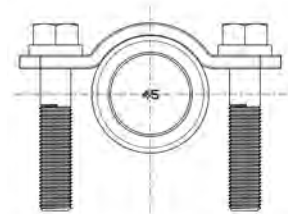

BEARING STRAP

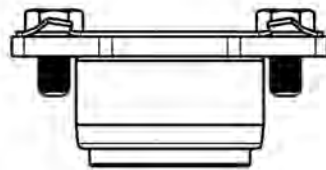

RETAINER PLATE

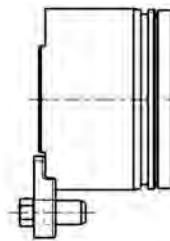
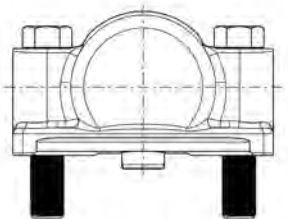
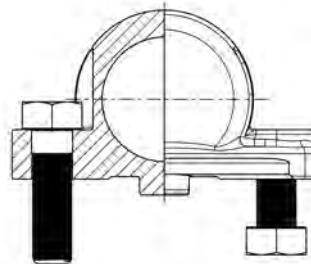

PLATE LOCK



DRILLED BLOCK
BEARING



WING BEARING:
1 DRILLED, 1
THREADED

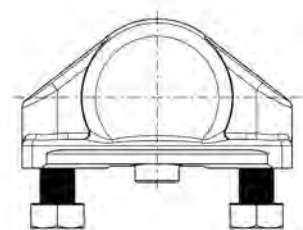

THREADED DELTA
WING BEARING

GENERAL INFORMATION

Neapco Driveline Components SECTION NUMBER (ID NUMBER) AND DESCRIPTION

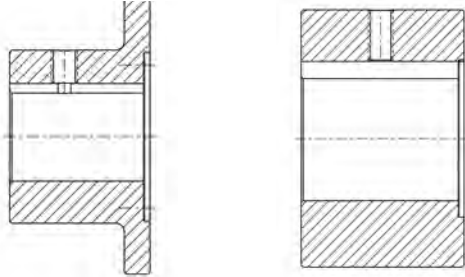

Section 1
(1) Companion Flange

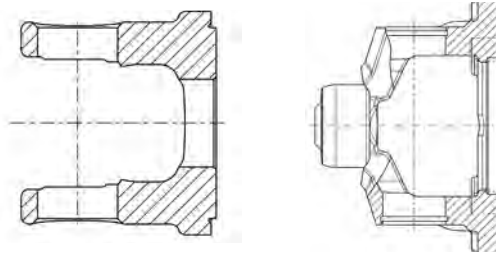

Section 2
(2) Flange Yoke (83) Flange Socket Yoke

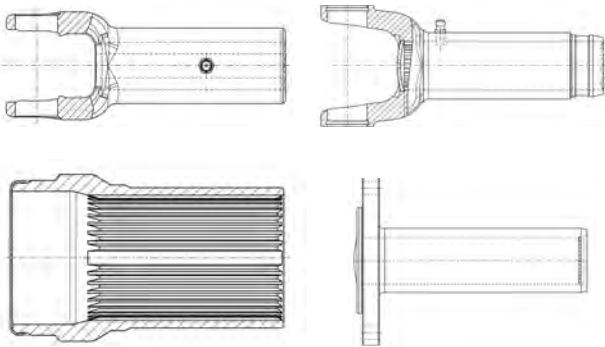

Section 3
(3) Slip Yoke (23) Flange Sleeve (55) Sleeve

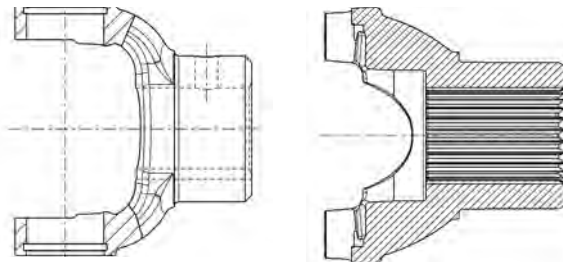

Section 4
(4) End Yoke

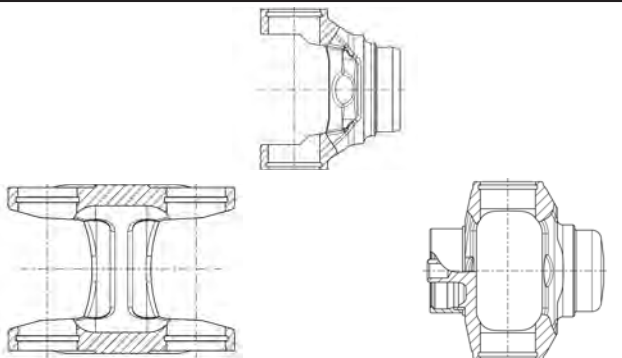

Section 5
(26) H-Yoke (26) or (28) Tube Yoke (28) Ball Stud Yoke

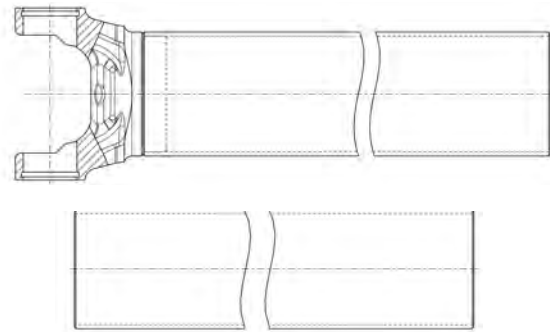

Section 6
(27) Yoke and Tube Assembly (30) Tubing

GENERAL INFORMATION

Neapco Driveline Components SECTION NUMBER (ID NUMBER) AND DESCRIPTION

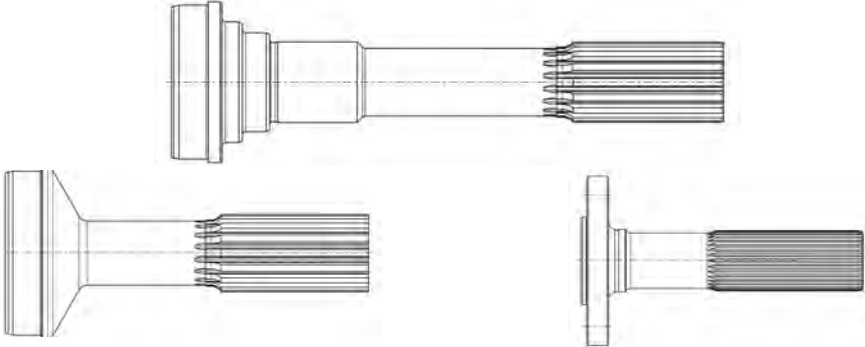
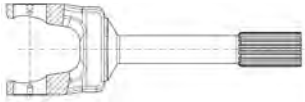
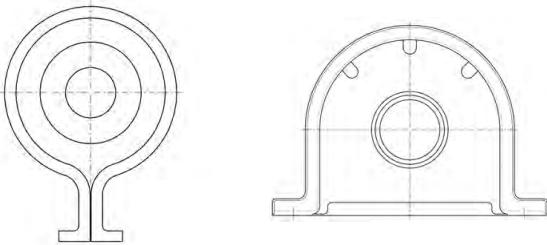
 <p style="text-align: center;">Section 7</p> <p>(40 & 42) Stub Shaft</p> <p>(53 & 54) Midship Stub Shaft</p> <p>(81) Flange Stub</p>	 <p style="text-align: center;">Section 8</p> <p>(82) Yoke Shaft</p>
<ul style="list-style-type: none"> · Double Cardan C.V. Repair Kit · Double Cardan C.V. Head Assembly · Double Cardan C.V. Head Components · PTO / AUX Shaft · Driveshaft · Driveshaft Components · Double Cardan Centering Repair Kits · PTO / AUX Shaft Shielding System <p style="text-align: center;">Section 9 Driveshaft Assemblies</p>	<ul style="list-style-type: none"> · Driveline Weights · Increasing Bushings · Pilot Reducer · Dust Seal · Welch Plug · Miscellaneous Fasteners · Miscellaneous Hardware · Driveshaft Boots · Centering Tools <p style="text-align: center;">Section 10 Small Parts</p>
 <p style="text-align: center;">Section 11 Center Support Bearings (N2xxxxx)</p>	

GENERAL INFORMATION

GENERAL INFORMATION

Typical Driveline Assemblies

SHORT COUPLED ASSEMBLY

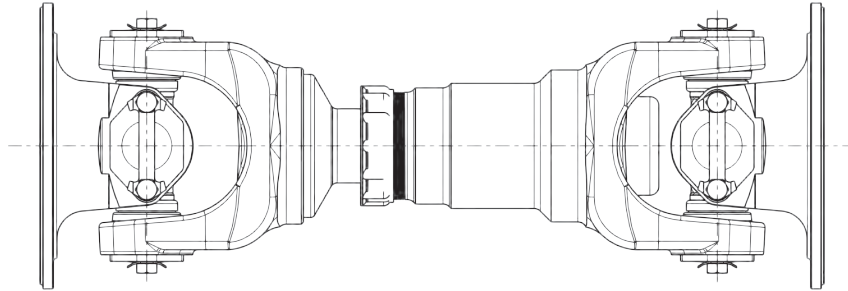

Short coupled assemblies are generally used in applications where space is limited and would not allow tubing to be utilized. A typical application would be between the axles of a tandem vehicle.

TWO JOINT ASSEMBLY

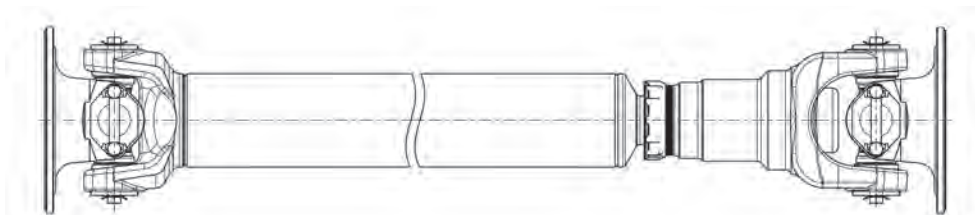

Two joint assemblies are used in applications that require the shaft assembly to lengthen and shorten due to movement by either or both of the connecting ends. A short wheel base vehicle is a typical application.

DOUBLE CARDAN CV ASSEMBLY

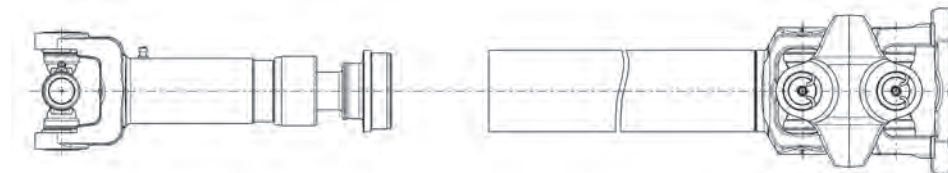

Double Cardan CV shaft assemblies are used in applications that require operating angles beyond the capability of standard single u-joints. The most common application is the front shaft of a 4 x 4 vehicle.

GENERAL INFORMATION

Typical Driveline Assemblies

CENTER BEARING STYLE

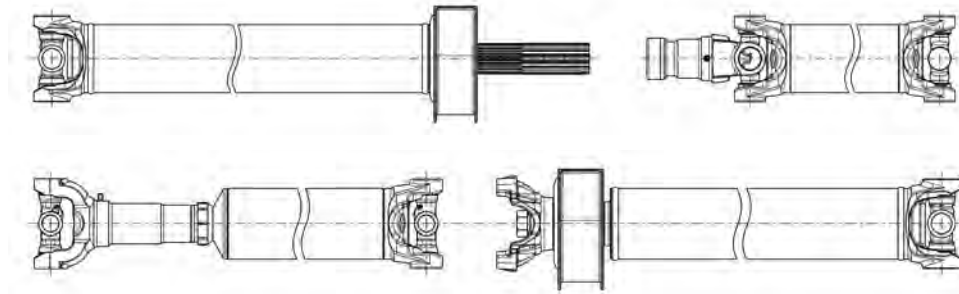

Shaft assemblies that use center bearings are typically used to span lengths beyond the capability of a single shaft. A minimum of one shaft assembly will have the ability to provide slip movement. An example is the main driveshaft of most medium duty straight chassis.

GENERAL INFORMATION

TYPICAL DRIVELINE ARRANGEMENT

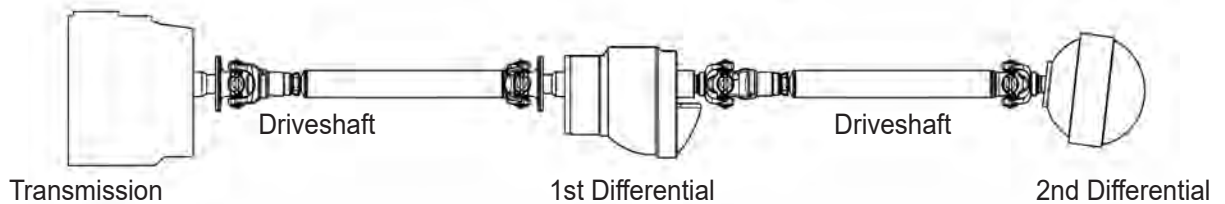

GENERAL INFORMATION

Basic Driveline Design Procedures & Precautions

In order to get the optimum service life out of any driveline and its components, it is important to start out with a driveline which is right for the application, and an application which allows the use of drivelines in their acceptable working ranges. There are five key elements that must be considered when building a driveline.

- 1 -OPERATING SPEEDS -TABLES I & II**
- 2 -OPERATING LOADS OR TORQUES -TABLE II**
- 3 -OPERATING U-JOINT ANGLES -TABLE III**
- 4 -LENGTH OF DRIVELINE -TABLE 1**
- 5 -DRIVELINE BALANCE**

Each of these elements, separately or in conjunction with each other, can lead to driveline problems and/or failure when not matched with the driveline capabilities.

The maximum operating speed must be held somewhat below the critical speed of the driveline, — 85% for passenger cars and light duty trucks and 75% for medium and heavy-duty trucks. The critical speed is a function of the tubing O.D., the tubing wall thickness, and the centerline to centerline length of the driveshaft. Operating at or near the critical speed of a driveline will cause substantial vibration and possible failure.

The maximum load that a driveline can carry is a function of joint rating, tubing O.D. and wall thickness, and component strength.

It is generally accepted that the major limiting factor in determining allowable U-joint operating angles is speed. Good design practice is to keep operating angles within the 0.5° to 3° range. Higher angles are permissible, depending on shaft speed. Another good design practice is to keep the difference in angles between two U-joints in the same driveshaft to within 1°.

Universal joint operating angles can be determined by measuring the angles of the various components and finding the resultant. A bubble or digital protractor is needed to measure the component angles. Measurements should be taken on machined surfaces, and partial disassembly of the driveline may be required to expose those surfaces. Common surfaces which are used to take angle measurements are: the outside face of yoke ears, flange faces and the outside diameter of the tubing.

Before Starting

When measuring drivelines to determine U-joint angles, it is good practice to start out with a sketch showing the basic driveline and where measurements are to be taken. Before measuring any angles, the vehicle must be parked on level ground with all tires inflated to their normal operating air pressures. Block the front tires to prohibit movement and place the transmission in neutral (Make sure that the parking brake is released). It may be necessary to jack up a rear wheel so that the driveline can be rotated to get the transmission output yoke ear parallel to the ground.

*Measure all angles on flat surfaces, which are clean and free from rust, scale or nicks.

The following is a typical procedure for determining U-joint operating angles:

1. Measure transmission output shaft angle and determine its direction (up or down), record.
2. Measure angle of driveshaft and determine its direction, record.
3. Measure angle of axle input yoke and determine its direction, record.
4. The difference between the transmission output shaft angle and the driveshaft angle is the transmission output U-joint operating angle.
5. The difference between the driveshaft angle and the axle input angle is the axle input U-joint operating angle.
6. Check difference of U-joint operating angle to make sure they are within 1° of each other.

Follow same pattern to determine U-joint angles in other driveshafts.

Below is a typical driveline arrangement and a sample U-joint angle calculation:

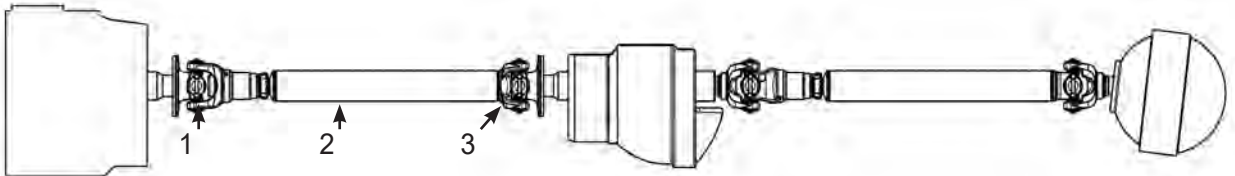

1. Transmission output angle = 3° (down)
2. Driveshaft angle = 4.5° (down)
3. Axle input shaft angle = 2.8° (down)
4. Difference between 3°(down) and 4.5°(down) = 1.5° This is the transmission output U-joint operating angle. (#1-#2)
5. Difference between 4.5°(down) and 2.8°(down) = 1.7° This is the axle input U-joint operating angle. (#2 -#3)
6. Difference between 1.5° and 1.7° = .2° This is less than the recommended 1° maximum. (#4-#5)

GENERAL INFORMATION

**Table I - Driveline Centerline To Centerline
MAXIMUM LENGTH AT MAXIMUM RATED RPM BY SERIES**

Series	Tube Size	Part No.	Max. RPM	Max. Length ¹
1000	2" x .083	N16-30-62	2500	54
1310	2"x .065	N16-30-32	6000	35
	2"x .083	N16-30-62	6000	35
	2"x .120	N16-30-102	6000	34
	2.5"x .065	N20-30-12	6000	39
	2.5"x .083	N20-30-22	6000	39
	2.16"x .065	N22-30-12	6000	41
	3"x .065	N24-30-82	6000	43
	3"x .083	N24-30-42	6000	43
	3.5"x .065	N28-30-42	6000	46
	3.5"x .083	N28-30-62	6000	46
1330	2.5"x .083	N20-30-22	5000	43
	3"x .065	N24-30-32	5000	47
	3"x .083	N24-30-42	5000	47
	3.5"x .083	N28-30-62	5000	51
1350	2.5"x .083	N20-30-22	5000	43
	2.75"x .083	N22-30-22	5000	45
	3"x .083	N24-30-42	5000	47
	3.5"x .083	N28-30-62	5000	51
1410	2.5"x .120	N20-30-62	5000	39
	3"x .083	N24-30-42	5000	47
	3.5"x .065	N28-30-42	5000	51
	3.5"x .083	N28-30-62	5000	51
1480	3.5"x .083	N28-30-62	5000	51
	3.5"x .095	N2&30-22	5000	50
	4"x .083	N32-30-22	5000	54
1550	3.5"x .095	N28-30-22	5000	50
	4"x .083	N32-30-22	5000	54
1610	3.5"x .134	N28-30-92	4500	53
1710	3.5"x .156	N28-30-52	4500	53
	4"x .134	N32-30-52	4500	57
	4.095"x .180	N32-30-72	4500	57
1760	4"x .134	N32-30-52	4500	57
	4.095"x .180	N32-30-72	4500	57
1810	4.5"x .134	N36-30~62	4500	60
SPL170*	4.73"x .197	N110-30-5	4000	60
	4.96"x .118	N120-30-3	4000	60
SPL250*	5.06"x .167	N120-30-4	4000	60
	5.12"x .197	N120-30-5	4000	60
	5.20"x .236	N120-30-6	4000	60

* SPL - Spicer ® Life Series driveshafts is a registered trademark of Dana Limited.

¹ Maximum centerline to centerline using a .75 safe speed factor generally accepted for medium and heavy duty trucks.

GENERAL INFORMATION

Table II- Universal Joint Torque Ratings

MAXIMUM OPERATING TORQUE CAPABILITY

SERIES	PART NUMBER	ELECTRIC	FUEL	MAXIMUM
		MOTOR	APPLICATION	
		(LBS-FT)	(LBS-FT)	
1000	1-0170	75	50	2500
1210	1-0315	95	65	6000
1280	1-0350	140	95	6000
1310	1-0153	195	130	6000
1330	2-4800	220	150	5000
1350	2-0053	310	210	5000
1410	2-0054	375	250	5000
1480	3-0188	500	335	5000
1550	3-0155	640	420	5000
1610	4-0279	975	640	4500
1710	5-0280	1330	895	4500
1760	6-0407	1630	1095	4500
1810	6-0281	1850	1245	4500
3C	3-3152	295	200	5000
4C	3-4138	375	250	5000
5C	4-5122	640	425	5000
6C	4-6143	875	575	5000
7C	5-7205	1150	775	4500
8C	6-8205	1750	1175	4500
9C	6-9016	2700	1800	3000
10C	6-1007	3800	2550	2500
7260	1-6301	195	130	5000
7290	2-1175	260	175	5000
3R	2-3011	260	175	5000
SPL170*	6-1170	1650	1125	4000
SPL250*	6-1250	1940	1306	4000

* SPL - Spicer ® Life Series driveshafts is a registered trademark of Dana Limited.

Table III - Operating Angles

Shaft RPM	Max Operating Angle	Shaft RPM	Max Operating Angle
1000	17°	3000	6°0'
1500	11°30'	3500	5°10'
2000	8°50'	4000	4°20'
2500	7°0'	4500	4°0'
		5000	3°20'

GENERAL INFORMATION

Basic Driveline Fabrication

TYPICAL TWO JOINT ASSEMBLY (1310 Series)

1. Stay within the boundaries of the five key elements in the basic driveline design procedures and precautions section.
2. Select appropriate components for the application. NOTE: We will use a typical hollow spindle lathe for assembly.
3. Cut the tubing to approximately 3/8 inch longer than the required length in a cutoff saw. Remove all burrs and weld flash from the inside of the tube.
4. Chuck the tubing in the lathe with approximately 2 inches protruding. Face the tubing to square it up, then chamfer I.D. and O.D.
5. Remove the tubing from the lathe and measure from the machined end to the required length. Scribe or mark the required length on the tube at two places (90 degree intervals).
6. Recheck the tubing with the marked end protruding from the chuck jaws approximately 2 inches. Rotate the tubing and mark the full diameter of the tube at the required length with a marker or grease pencil.

7. Face the tubi

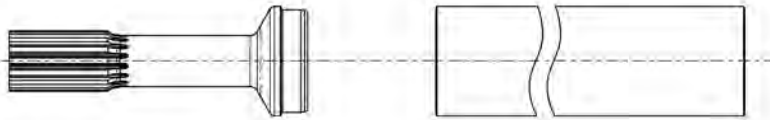

8. Remove the tubing from the lathe then tamp or press the slip stub into either end of the tubing. (NOTE: if tamping method is preferred, a lead plate should be the surface tamped against.)
9. Place back into lathe with approximately 3 3/4 inches of tubing protruding from the jaws and slip stub pointing toward the bed of the lathe.
10. Move tail stock into position with center located into the center hole in the slip stub.

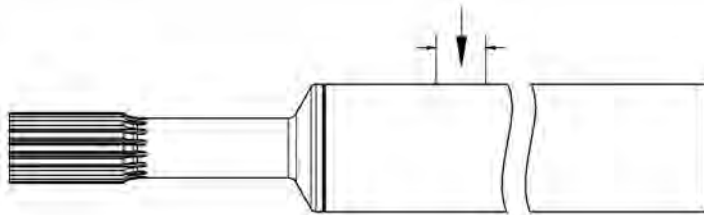

11. Clean the tubing approximately 3 inches from the slip stub around the full diameter of the tube. A 3/4 to 1 inch wide band will be sufficient. Emery cloth can be used.

GENERAL INFORMATION

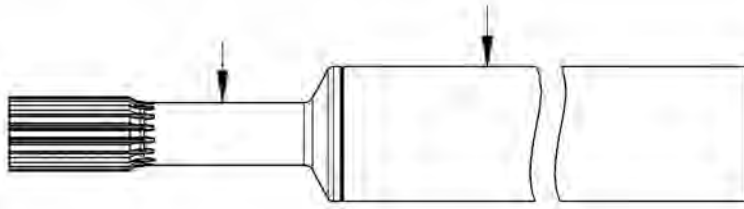

12. Check the runout on the ground diameter of the slip stub and 3 inches in on the tubing (cleaned area) with a dial indicator.

Maximum runout 3 inches on tubing = .020

TIR Maximum runout slip stub = .005 TIR

Correct, if necessary, to stay within the runout tolerance.

13. Tack weld in place at 90 degree intervals.

NOTE: Insure that the bed of the lathe is protected from welded spatter whenever welding with component in the lathe.

14. Recheck runout and correct, if necessary. (Refer to step 12)

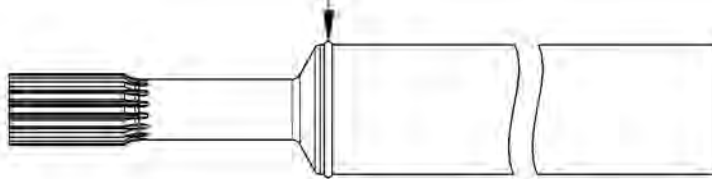

15. Weld single pass starting at the high point determined by the dial indicator.

16. Allow driveshaft to cool then recheck runout.

NOTE: Do not use any oil, water or an air jet to cool the driveshaft.

17. Remove shaft from lathe and partially tap new tube yoke into tube.

(a) The components must be properly phased at this time. (NOTE: Alignment arrows unique to Neapco slip yokes will ease the phasing procedure.)

(b) Some driveshafts are manufactured with special phasing. In this case, the equipment manufacturer's service manual or specifications must be consulted to obtain phasing angles and tolerances.

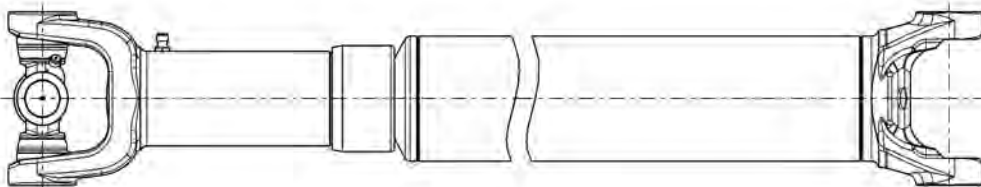

18. Clamp shaft in a pipe vise with slip yoke temporarily assembled on the slip stub with the ear lugs of the slip yoke and tube yoke pointing upwards. Pipe vise should be on the tube yoke end of the shaft.

19. Support the opposite end of the shaft with an open steady rest near the slip stub on the tubing.

GENERAL INFORMATION

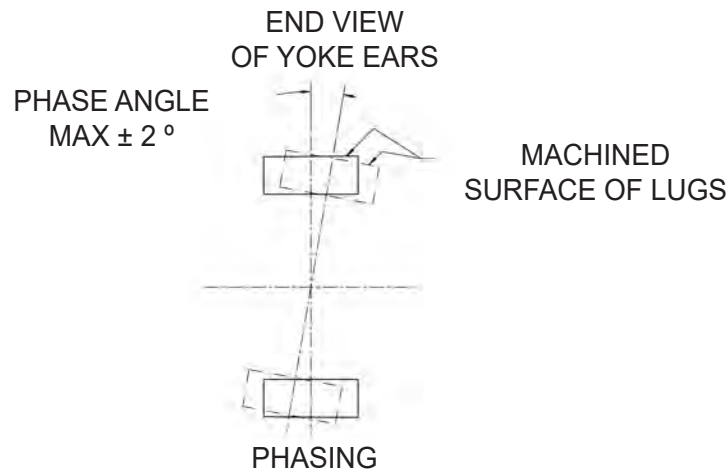

20. Place a straight edge on the machined surface of the lug on the slip yoke and align by eye with a second straight edge on the lug of the tube yoke. Correct if necessary.

21. Use a protractor level for final phasing. The cross holes of the 1310 Series drive line must be in line within plus or minus 2° maximum.

22. With tube yoke tapped into proper phasing, remove slip yoke and shaft from vise. Press or tamp tube yoke into position.

NOTE: Use a lead pad if tamping method is used.

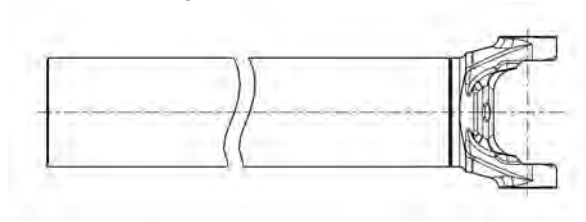

23. Place the shaft back into the lathe with the proper fixturing (adapters), tube yoke towards the tail stock.

24. Clean the tubing approximately three inches from the tube yoke around the full diameter of the tube. A 3/4 to 1 inch wide band will be sufficient. Emery cloth can be used.

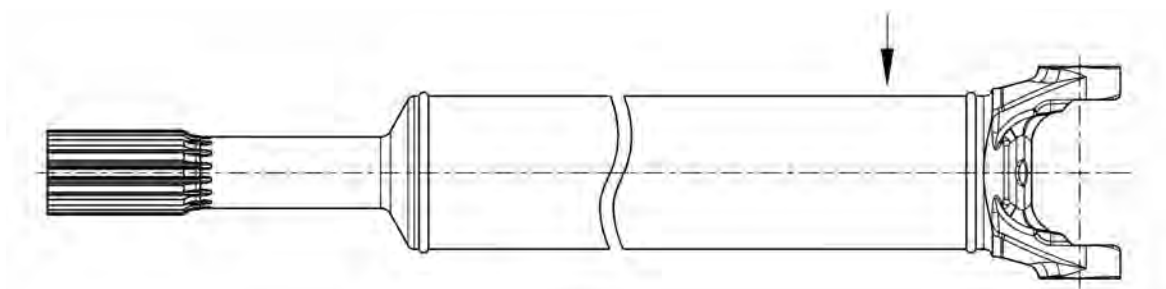

GENERAL INFORMATION

25. Check the runout three inches in on the tubing from the tube yoke end with a dial indicator. Maximum runout three inches on tubing = .020 TIR
26. Tack weld tube yoke in place at 90 degree intervals.
NOTE: Insure the bed of the lathe is protected from weld spatter.
27. Recheck runout and correct, if necessary. (Refer to step 25)
28. Weld single pass starting at the high point determined by the dial indicator.
29. Allow driveshaft to cool then recheck runout.
NOTE: Do not use any external cooling methods, i.e. water, oil or air jets.

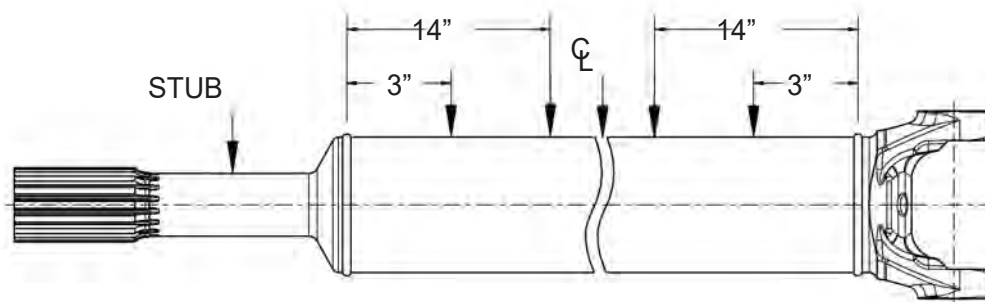

30. Adapt assembly to centers in the lathe and clean 3/4 to one inch wide bands using emery cloth at 14 inches from each weld on the tube and in the center of the tube. Check the runout at the following areas with a dial indicator:

- MAXIMUM RUNOUT THREE INCHES FROM EACH WELD = .020 TIR
- MAXIMUM RUNOUT 14 INCHES FROM EACH WELD = .010 TIR
- MAXIMUM RUNOUT ON GROUND DIAMETER OF SLIP STUB = .005 TIR
- MAXIMUM RUNOUT AT CENTER OF TUBE (OVER 30") = .010 TIR
- MAXIMUM RUNOUT AT CENTER OF TUBE (UNDER 30") = .020 TIR

NOTE: Do not include tubing ovality.
Refer to driveshaft straightness tolerances section for other series

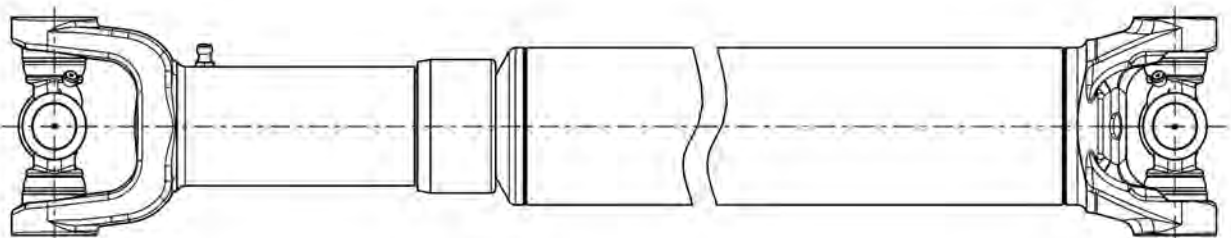

GENERAL INFORMATION

- 31. Assemble U-Joints and slip yoke into the newly fabricated driveshaft making sure that alignment arrows match up. Balance to specification. Balancing will vary depending on the type of balancer being used. Refer to the manufacturer's procedure for the type of equipment being utilized.
- 32. Paint the completed driveline and place a decal or sticker on it with your shop logo.

This procedure describes a typical 1310 two-joint assembly fabrication. Methods may vary due to type of equipment utilized. The method may also be followed when repairing a driveline: Simply follow the appropriate steps pertaining to the components in need of replacement. —To fabricate other than 1310 Series refer to the appropriate series data where noted in each procedure.

- ALWAYS REPLACE DAMAGED COMPONENTS
- ADHERE TO ALL SHOP SAFETY PROCEDURES
- ALWAYS STAY WITHIN SPECIFIED TOLERANCES
- ALWAYS BALANCE YOUR DRIVELINE

Phasing Specifications

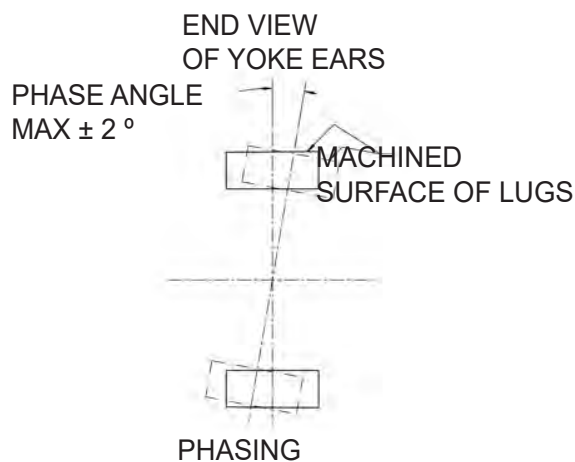

The cross holes of all two joint driveshafts must be in line within ± 2° Maximum.

GENERAL INFORMATION

Driveshaft Straightness Tolerances

1000 THRU 1480 — ALSO 7260, 7290, 3R, AND 3C

After welding, runout (not to include tubing ovality) should never exceed the TIR (total indicator reading) as detailed below.

FOR TUBE LENGTH OVER 30"

MAXIMUM RUNOUT 3 INCHES FROM EACH WELD = .020 TIR

MAXIMUM RUNOUT 14 INCHES FROM EACH WELD = .010 TIR

MAXIMUM RUNOUT ON GROUND DIAMETER OF SLIP STUB = .005 TIR

MAXIMUM RUNOUT ON BEARING DIAMETER IF CENTER BEARING STUB IS USED = .003 TIR

MAXIMUM RUNOUT AT CENTER OF TUBE = .010 TIR

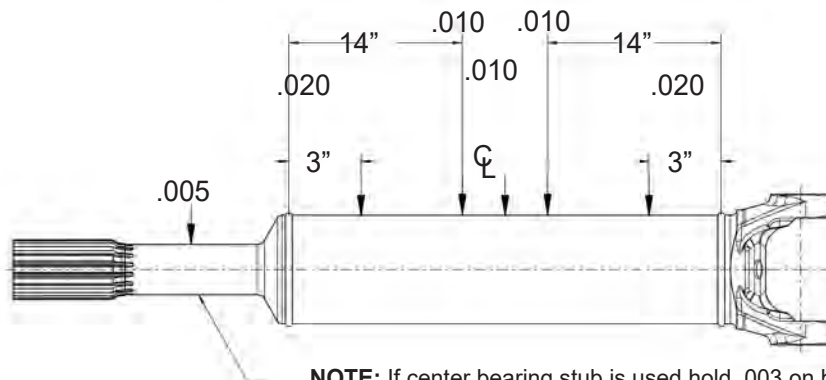

FOR TUBE LENGTH UNDER 30"

MAXIMUM RUNOUT 3 INCHES FROM EACH WELD = .020 TIR

MAXIMUM RUNOUT AT CENTER OF TUBE = .020 TIR

MAXIMUM RUNOUT ON GROUND DIAMETER OF SLIP STUB = .005 TIR

MAXIMUM RUNOUT ON BEARING DIAMETER IF CENTER BEARING STUB IS USED = .003 TIR

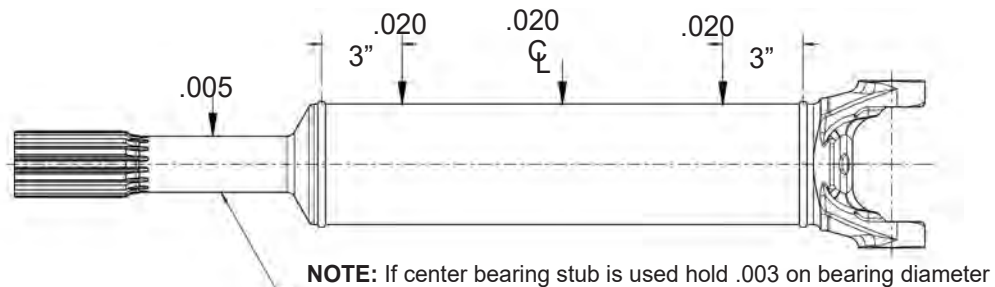

GENERAL INFORMATION

GENERAL INFORMATION

Driveshaft Straightness Tolerances

1550 THRU 1810 — ALSO 4C THRU 10C

After welding, runout (not to include tubing ovality) should never exceed the total indicator reading as detailed below.

FOR ALL TUBE LENGTHS

MAXIMUM RUNOUT 3 INCHES FROM EACH WELD = .010 TIR

MAXIMUM RUNOUT ON GROUND DIAMETER OF SLIP STUB = .005 TIR

MAXIMUM RUNOUT ON BEARING DIAMETER IF CENTER BEARING STUB IS USED = .003 TIR

MAXIMUM RUNOUT AT CENTER OF TUBE = .015 TIR

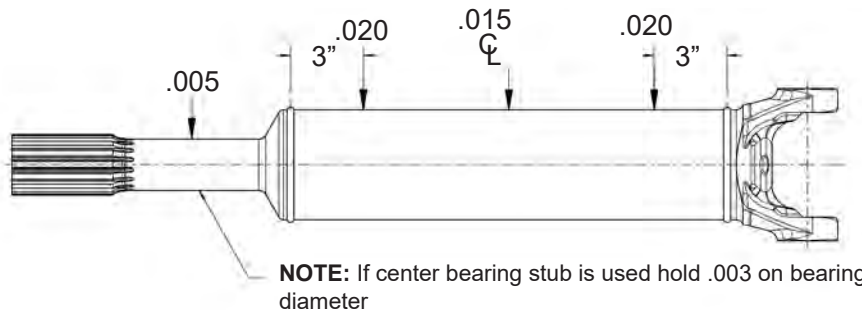

GENERAL INFORMATION

Lubrications

WHY LUBRICATE?

Proper lubrication of any moving parts in a driveline is essential to keep the driveline in proper working order and to obtain an acceptable service life.

WHAT SHALL I LUBRICATE?

All universal joints, slip yoke and stub shaft assemblies, as well as centering kits in CV heads should be greased regularly.

HOW?

Universal Joints

Secure grease gun on grease fitting and pump in grease until all four bearings are lubricated. To check for this, make sure that all four seals have purged out air and old grease. Grease until fresh grease appears at the base of all four seals. If a seal does not purge properly, move the driveline to free up the end to end clearance of the bearing cup. On bearing plate style U-joints, it may be necessary to loosen the bolts two or three turns to allow grease to flow. If the joint still does not grease properly, disassemble the kit to determine the source of the problem.

Slip Yoke and Stub Shaft Assemblies

Before putting the slip yoke onto the stub shaft, coat both parts uniformly with a layer of grease. After assembly, but before installation into vehicle, fully collapse the driveline and apply grease to the grease fitting until it comes out of the vent hole in the welch plug. Cover the hole and continue greasing until grease appears at the seal.

At relubrication it may be impossible to fully collapse the driveline. Follow the same general greasing procedure but be careful not to overfill. Overfilling may cause the welch plug to pop out during operation.

Centering Kits

A special needle nose grease gun adaptor is needed to grease the flush type fitting on centering kits. Apply grease until fresh grease appears at purge hole or at ball seal.

WHEN SHALL I LUBRICATE?

Frequency of lubrication is determined by the type of service which the driveline is subject to. A list of recommended relube cycles for various service conditions is shown below:

Service Conditions	Re-lube Period	Approximate Miles
City	Every 3 Months	6,500
Highway	Every 3 Months	15,000
Off Highway	Every 1 Months	6,500
Line Haul	Every 3 Months	20,000-30,000
Off Highway 4x4	Every 1 Month	2,500

(Relube on period or miles, which ever comes first)

WHAT TYPE OF GREASE SHOULD I USE?

A good quality Lithium Complex soap type EP (extreme pressure) grease, with an NLGI grade2, is recommended.

GENERAL INFORMATION

General Procedures For Assembling Aluminum Driveshafts

Tools Required:

Push-Up Press or Enerpac Hydraulic Press
Centering Tools (Available from Neapco)
“Weld Aid” Cleaning Agent

Assembly procedures for aluminum driveshafts are similar to the procedures Driveline Specialists are familiar with. The most significant difference is the set-up of the welding equipment to allow successful welding of aluminum. Neapco recommends that the Driveline Specialist contact the manufacturer of their welding equipment for set-up specifications and training for welding aluminum.

Preparing the Components:

The tubing and tube weld yokes should be clean and free of burrs. Aluminum is fragile compared to steel, so be careful when handling these components during and after assembly.

1. Chamfer the I.D. of the aluminum tubing to remove any burrs or sharp edges.
2. Clean the inside and outside of the aluminum propeller shaft tubing – a minimum of 2” in from each end using “Weld Aid” cleaning agent or similar cleaning product available from your local welding supply source. Repeat this cleaning procedure for the entire surface of both turned diameters on the aluminum tube weld yoke.
3. Wash both ends of the tubing and tube weld yoke in clean water. Wipe the I.D. and O.D. end of the tubing and the entire tube yoke with a clean, dry towel or cloth until completely dry. Note: Successful welding of aluminum is directly related to cleanliness. Towels or cleaning clothes should be used for aluminum work only and changed frequently. Rinsing water should be placed in a clean container and changed when any signs of contamination are evident. Oil, grease or any foreign material will cause a potential blow hole in the weld.
4. Using a push-up machine or Enerpac and fixtures specifically designed for driveshaft fabrication, assemble the aluminum tube weld yokes into the tubing. Correct phasing (alignment of the yoke ears) is critical to the satisfactory performance of the driveshaft. Adjust phasing so that the yoke ears are in line with each other. (This can be checked with a precision level.) Adjust, if necessary, before proceeding to press.
5. A .090” gap (approximately twice the thickness of the weld wire) should be left between the turned shoulder of the tube weld yoke and the end of the tubing. Spacers should be made for both ends and inserted into the gap between the two components to avoid over pressing. Press until shim stock is snug at both ends, but avoid over pressing. After removing shim stock there should be a minimum of .090” gap.
6. The assembled driveshaft is now ready to be set up for welding. The rotation rate should be set for the tube size you are welding.

Approximate Tube Rotation Rate

Tube Dia.	RPM	Seconds Per Rev.
3.0”	3.18	19
3.5”	2.73	22
4.0”	2.39	25
5.0”	1.60	32

GENERAL INFORMATION

General Procedures For Assembling Aluminium Driveshafts

The rotation rate is a guideline. Neapco recommends that you contact the supplier of your welding equipment or your local welding supply service for set up of your specific equipment.

A dial indicator should be used to check the runout at each end of the tubing. Using a dead blow hammer tap over the joint between the tube weld yoke and the tubing until the runout is close to 0.000" as possible, but not to exceed .005". This will help to keep the finish welded assembly within .010" TIR at the welds. The middle of the tube should have no more than .015" runout.

Tube Straightening Hint – An arbor press with a 2 ft. piece of wood mounted on the ram with a "V" cut in it to fit over the O.D. of the tube can be used to over press the tubing in the opposite direction of the measured runout. This extra step will not only ease the balancing operation; it is sound driveshaft fabrication practice.

7. The weld gun tip should be aligned with the center of the gap between the tube weld yoke and the tubing. The wire should be perpendicular to the tube/tube yoke surface and at a 12o-15o angle from the centerline of the tubing. The weld should start and end (with ½" overlap) in line with one of the yoke ears. The driveshaft is now ready to weld. Neapco recommends formal training in aluminum welding from your equipment supplier. There is no substitute for practice and hands-on experience.

After the shaft has cooled, the welds should be visually inspected. Any visible porosity is a sign that some contamination was present. Visible porosity in an aluminum weld is a sign of a potential failure point. Any sign of an inferior weld other than an occasional small pin hole should be cause for replacement of the product.

Balancing the Aluminum Driveshaft

1. Assemble end connections to the driveshaft (slip yoke and pinion yoke, if available). Balance the assembly to .250 oz./in. maximum at each end of the shaft.
2. Position the appropriate balance weight on the barrel / shoulder area of the yoke or yokes. Balance weights may be taped in place, using fiber reinforced duct tape, full length around the yoke barrel / shoulder area.
The driveshaft should be rechecked for proper specifications (within .250 oz./in. total at each end).
3. After verifying correct balance performance, the balance weights should be attached. While aluminum balance weights may be attached by spot welding, or epoxy. If using epoxy, Neapco recommends using a two-part chemical Epoxy bond for attaching balance weights. The exact position of the weights should be marked for reinstallation while removing the duct tape. Using Epoxy Quik-Bond from J-B Weld or similar product, coat each surface with a thin layer of the epoxy. The balance weight should carefully be pressed into position. The weight must not be disturbed after installation. The shaft should be set aside until initial curing occurs. The weight should then be taped in place until the epoxy has ample time to dry before the driveshaft is installed in the vehicle. Note: There are many fast dry epoxies on the market today. Choose the proper product for your needs.

GENERAL INFORMATION

Auxiliary Power Take-Off Technical Information

POWER-TAKE-OFF (PTO) BASICS

An auxiliary power-take-off shaft transmits power from the source to the driven accessory. The shaft must be capable of transmitting the peak torque and maximum R.P.M. required by the accessory, while withstanding any shock loads. The information in this publication is focused on 1000 and 1310 series auxiliary power-take-off products.

An auxiliary power shaft operates through constantly changing angles between the power source and the driven accessory. Chassis twisting and power train deflections due to torque contribute to these changes in operating angles. This deflection also will cause changes in the length of the auxiliary power shaft. Including a slip member (slip yoke and spline stub shaft) in the driveline system accommodates this.

Joint operating angles are very important considerations in the configuration of an auxiliary power-take-off application. The service life of the universal joint is directly affected by the operating angles experienced in the completed system. Guidelines for permissible operating angles are identified in the accompanying chart.

UNIVERSAL JOINT OPERATING ANGLES			
SHAFT RPM	MAXIMUM NORMAL OPERATING ANGLE	SHAFT RPM	MAXIMUM NORMAL OPERATING ANGLE
500	17°	2500	7°
1000	17°	3000	6°
1500	11°	3500	5°
2000	8°		

SPECIFYING SHAFT TYPE

Applications in auxiliary PTO use either solid shafting or tubular driveshaft assemblies.

Neapco tubular auxiliary PTO shaft kits are manufactured using 2" diameter by .083" wall (2" x .083) tubing. These unwelded assemblies are convenient for fabricating different length driveshaft requirements as needed. Neapco recommends using tubular auxiliary PTO shafts whenever possible. Neapco tubular shafts are designed to reduce vibration as a dynamically balanced assembly. Minimizing vibration increases the service life of the driveshaft, universal joints, bearings in the driving and driven units and helps keep end connections secure.

Solid shafting should only be used in auxiliary power-take-off applications designed for 1,000 R.P.M. or less intermittent service.

INSTALLING A PTO DRIVELINE

When installing a remote-mount PTO, one requiring a propeller shaft (driveline), please observe that there is a slight angle of inclination to the engine, and that you must install the driven shaft of the pump parallel to the PTO output shaft. In addition, the yokes of the PTO driveshaft should be in line, in phase, and in the same plane.

Auxiliary Power Take-Off Technical Information

Some light-duty under body hoist applications use a pump and tank combination, and there are many large tank trucks which have pneumatic blowers. Both require a level horizontal installation, making parallel input and output shafts difficult to configure. The correct remedy for this common driveline problem is to use a two-piece driveshaft. In close-coupled applications a center yoke assembly may be necessary to provide correct phasing and angularity.

To properly measure the driveline angle, use a bubble or digital protractor to determine TRUE JOINT ANGLE, which is a composite of vertical and horizontal components. This can also be calculated by measuring and using trigonometry. We recommend that you install with at least a two-degree angle, to insure that oscillations will properly rotate the needle bearings in the u-joints.

If a long driveshaft is necessary then critical speed problems must be taken into consideration. The solution is to use more than one driveshaft, installed with center support bearing assemblies, and design the driveshaft lengths to avoid critical and half-critical speeds. Usually the best solution is to install 60% of the driveline closest to the source of power, or the driving end, with the remaining 40% toward the driven end. Pillow blocks, flange bearings or hanger bearings used in two-piece driveshafts must be mounted solidly to the chassis.

WHERE TO INSTALL THE SLIP JOINTS

The purpose of the slip joint (slip yoke and spline stub shaft) is to allow proper flexing of the universal joints as they rotate through the entire circle of operation. If a slip joint is not installed, or if it is corroded from lack of lubricant, then severe stresses are imposed upon the bearings and seals in the PTO and pump. An additional purpose of the slip joint is to allow flexing of the chassis without putting lateral loads on the bearings and seals. Bearing and seal damage in PTOs and pumps, and overheating is nearly always attributable to driveline problems.

Our recommendation is that if you have enough space, ***the slip joint should be installed on the end closest to the PTO.*** If the PTO is inadvertently left in gear, the slip joint may leave the shaft during overspeeding, or operating above critical speed.

CAUSES OF DRIVELINE FAILURES

To review u-joint and driveline problems, most failures will be a result of one or more of the following:

- EXCEEDING TORQUE OR LOAD RATING
- LACK OF LUBRICANT OR DIRTY LUBRICANT
- HIGH DEGREE OF ANGULARITY
- U-JOINTS NOT IN PHASE
- U JOINT ANGLE NOT EQUAL
- DRIVELINE NOT ALLOWED TO SLIP
- DRIVELINE OUT OF BALANCE

If you must use a driveline, it is our recommendation that you use tubular assemblies, and that you purchase from a certified driveline specialist.

GENERAL INFORMATION

Neapco Auxiliary PTO Driveshaft Shielding System

Neapco®, has developed an Auxiliary PTO Driveshaft shield System that is compatible with many 1000 and 1310 Series power-take-off applications. The system consists of four (4) basic components that combine to form a total driveline enclosure system.

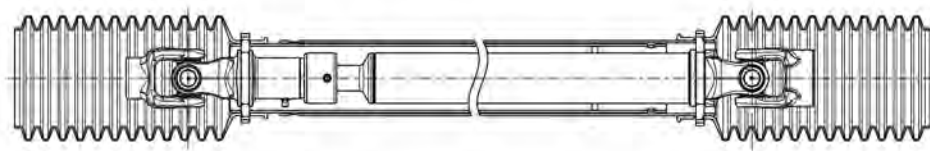

N10270-SF and N10271-SF are equipped with grooves for shield bearings. For all other part numbers choose the appropriate mounting collars.

- 1) A series of Bearing Races (collars) for installation on the driveshaft assembly by tack welding.
- 2) Flex Bell™ Yoke Enclosures with over 8" of coverage featuring fluted construction for easy length adjustment by cutting, providing custom installations.
- 3) Inner (2.75" O.D.) and Outer (3.00" O.D.) Telescoping Plastic Shield Tubes complete with bearing slots (4) and Danger Label. Designed for easy length adjustment by cutting to desired length with bearing slots aligned with bearing races (collars) mounted on the driveshaft. These shields must overlap (telescope) at least 5" or more, if design allows. To accomplish this the shield tube should be cut at least 2 1/2" past the center of the driveshaft with the bearing slots aligned with the bearing race (collars) on the driveshaft.
- 4) Inner (4) and Outer (4) Shield Bearing Sets. These bearing sets lock the Flex Bell™ Yoke Enclosure to the mating shield tube through the aligned slots and ride in the bearing races on the driveshaft collars.

Assembly is easily accomplished after a short orientation to the system. Disassembly (for service work or lubrication) takes only a few minutes with a blade screwdriver.

Shield Bearings must be installed properly in regards to the rotation of the driveline. This prevents the Shield Bearings from loosening or popping out of the Bearing slots.

DIRECTION OF ROTATION

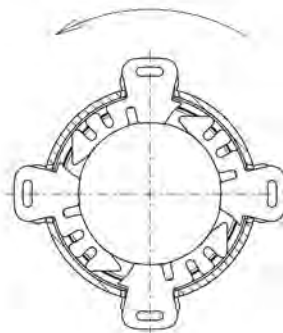

GENERAL INFORMATION

Troubleshooting Guide

PROBLEM	POSSIBLE CAUSE	CORRECTIVE ACTION
1. Fractured cross or trunnion or bearing cup.	A. Excessive running load. B. Shock load. C. Insufficient joint capacity. D. Excessive running angle.	A, B & C, Replace with higher capacity driveshaft and U-joint. D. Reduce U-joint angle.
2. Early life U-joint failure	A. Inadequate lubrication. B. Seal failure. C. Excessive running angle and excessive speed. D. Excessive running load.	A Lubricate at minimum recommended intervals with recommended lubricant. B. Replace U-joint. C. Reduce running angle. D. Replace with higher capacity driveshaft and U-joint.
3. Galling of U-joint trunnion end and bearing cup pad.	A. Excessive running angle and excessive speed. B. End to end fit too tight. C. Inadequate lubrication.	A. Reduce U-joint angle. B. Replace U-joint. If replacement kit is tight, check yoke alignment and lockup size: replace yoke. C. Lubricate at minimum recommended intervals with recommended lubricant.
4. Brinnelling of bearing surfaces.	A. Normal fatigue wear. B. Excessive running angle and excessive speed. C. Excessive running load. D. Needle skewing. E. Improper running angle. F. Inadequate lubrication.	A. Replace U-joint. B. Replace U-joint angle. C. Replace with higher capacity driveshaft and U-joint. D. Replace U-joint; check for yoke distortion. E. Maintain minimum recommended running angle (typically 1°). F. Lubricate at minimum recommended intervals with recommended lubricant.
5. Slip assembly seizes up.	A. Inadequate lubrication. B. Seal failure.	A, B. Replace components. Lubricate at minimum recommended intervals with recommended lubricant.

GENERAL INFORMATION

Troubleshooting Guide

PROBLEM	POSSIBLE CAUSE	CORRECTIVE ACTION
6. Slip assembly galling.	A. Seal failure leading to contamination. B. Excessive running load. C. Inadequate driveline design; length of spline engagement too short, normal running condition with spline at pulley extended position.	A. Replace assembly. B. Replace with higher capacity driveshaft and U-joint. C. Increase length of spline engagement with longer splined stub. Review driveshaft length requirements and rebuild with stub spline centered in yoke at normal running condition.
7. Stub shaft or tubing failure in torsion.	A. Excessive running load. B. Shock load. C. Inadequate driveline design: tube size too small.	A, B, C. Replace with higher capacity driveshaft.
8. Failure at tube weld.	A. Improper weld. B. Excessive running load. C. Balance weight welded too close to tube weld.	A, C. Replace tube. B. Replace with higher capacity driveshaft.
9. Yoke ear failure.	A. Ear, contacted yoke ear of other yoke in assembly while running.	A. Reduce running angles; use yoke with higher angle rating.
10. Yoke hub failure.	A. Excessive running load. B. Excessive secondary couple loads.	A. Replace with higher capacity driveshaft. B. Reduce running angles.
11. Center support bearing failure.	A. Seal failure. B. Mated with an oversized stub shaft	A, B. Replace with new components.
12. Center support rubber cushion failure.	A. Misalignment. B. Located too close to heat source.	A. Replace and align. B. Shield from heat or move away from heat source.
13. Driveline vibration.	A. Improper assembly. B. Excessive or unequal running angles. C. Defective U-joint. D. Driveshaft out of straightness and balance specifications. E. Worn slip assembly components. F. Driveline length exceeds maximum for speed range.	A. Make sure all snap rings or bolts are fully seated or torqued properly. B. Reduce and equalize running angles. C, E. Replace with new components. D. Straighten and balance. F. Redesign using larger diameter tubing or two piece driveline.

GENERAL INFORMATION

Glossary of Common Terms

Bearing Plate	A retainer plate fixed to the back of a round bearing used to position the bearing in the yoke.
Balancing	A procedure in which the distribution of mass in a rotating body is checked and altered where necessary to ensure that vibration does not occur during operation.
Ball Seat	A full or segmented angular contact bearing located in a socket that supports and centers the ball stud.
Ball Stud	A yoke generally used in CV applications which incorporates a stud onto which a ball is mounted.
Brinnelling	Failure that occurs when the static forces between two curved surfaces in contact result in local yielding of one or both mating members to produce permanent surface discontinuity. Example: Needle roller indents on a u-joint trunnion or trunnions.
Cardan Universal Joint	A non-constant velocity universal joint consisting of two yokes connected by a cross through four bearings and driveable by external sources.
Center Support	A rolling bearing element surrounded by rubber, mounted in a bracket configuration used to mount the support to an outside structure.
Centering Socket Yoke	A yoke assembly that functions as a self-aligning bearing and provides support and a means of centering in double cardan universal joints.
Companion Flange	A flanged member that attaches a driveline to drivetrain components, typically affixed by some bolt-together method.
Critical Speed	The speed at which the rotational speed of a shaft coincides with the natural vibration frequency of the shaft, causing a dynamically unstable condition.
Cross and Bearing Kit	Drive member with four equally spaced trunnions in the same plane and four bearing cups with attaching parts. Also referred to as a universal joint kit or u-joint kit.
Cross Hole	A through hole located in each ear of a yoke used to locate a round bearing.
Double Cardan Universal Joint	A near constant velocity universal joint consisting of two trunnion type Cardan universal joints whose trunnion yokes are connected by a coupling yoke or H-yoke with internal supporting and centering means.

GENERAL INFORMATION

Glossary of Common Terms

Driveline	An assembly of one or more driveshafts with provisions for axial movement, which transmits torque and/or rotary motion.
Driveshaft	An assembly of one or two universal joints connected to a solid or tubular shaft member.
Driveshaft Length Center to Center	The distance between the outermost universal joint centers on a driveshaft.
Drive Train	Term used for the unit of all components from the Transmission to Rear differential. Also referred to as Power Train.
Ear	One of two projecting parts of a yoke symmetrically located with respect to the rotational axis.
End Yoke	A yoke which attaches a driveshaft to another drive train component such as the transmission.
Flange Yoke	The yoke which attaches the driveshaft assembly to a companion flange.
Flinger	A protective shield used in front of and behind the bearing and rubber on many center supports and end yokes.
Galling	Failure that occurs when two sliding surfaces are subjected to such a combination of loads, sliding velocities, temperatures, environments, and lubricants, that massive surface destruction is caused by welding and tearing, plowing, and gouging. Example: Bearing cup/trunnion end galling on a cross and bearing kit.
H-Yoke	A double yoke which connects the two halves of a double cardan universal joint.
Half Round Yoke Cross Hole	A semicircular hole located on the end of each ear of some end yokes and used to locate a round bearing.
Hub	The central part of a yoke used for attachment to another member.
Inside Lock-up	Term referring to either a cross and bearing kit or a yoke that utilizes a snap ring seated in a groove in the bearing cups and located inside the yoke ears to retain the kit in the yoke.
Joint Angle	The angle described by the intersection of rotational axis of the input and output members of a universal joint and measured on the same plane described by these areas.
Liner	A sound and vibrational deadening material added to the inside surfaces of a tube.

GENERAL INFORMATION

Glossary of Common Terms

Lock-Up	The dimensional distance between the two retaining surfaces in a driveline component used to locate the bearing surfaces.
Midship Stub Shaft.	A short shaft, generally splined, used in applications requiring more than one driveshaft. It mounts through the center of a support bearing and allows an additional driveshaft component to be fixed.
Outside Lock-Up	Term referring to either a cross and bearing kit or a yoke that utilizes a retaining ring in a groove near the outside edge of the yoke ear, rested against the outside face of the bearing cup.
Phase/Phase Angle	The relative positioning of the universal joint yokes on a driveshaft or driveline.
Retaining Ring	A removable ring used as a shoulder to retain and position a round bearing in a hole.
Ring Groove Round Bearing	The surface used for positioning a round bearing with a retaining ring. Consists of a round bearing cup with needle rollers designed to ride on a trunnion.
Seal	A flexible member which prevents the escape of lubricant and the entrance of foreign matter.
Slip Movement	A permissible length of axial movement.
Slip Stub Shaft	A short, machined shaft, generally splined, which, when used with a slip yoke allows axial movement.
Slip Yoke	A yoke which allows axial movement.
Snap Ring	Same as retaining ring.
Strap Bearing Clamp	A semi circular device that conforms to the bearing profile holding them in place in half round and some DC yokes.
Swaged Tubing	A tube with one or both ends having a smaller diameter than the middle section.
Swing Diameter	The maximum diameter of the circular path described by a rotating universal joint.
Thrust End	The end of a cross trunnion used as a thrust surface.
T.I.R.	Total Indicator Reading on a specific point thru 1 revolution of a shaft.
Torsional Damper	A mechanical device, generally an inertia ring, attached to a drivetrain component by means of a rubber inner ring to minimize driveline vibration in addition to balancing.

GENERAL INFORMATION

Glossary of Common Terms

Trunnion	One of four projecting journals of a cross.
Tubing	The tubular connecting member of a driveshaft.
Tube Diameter	The outside diameter of a tube.
Tube Yoke	A yoke with a piloting hub for attachment of a tube.
U-Bolt	A clamping bolt with two parallel threaded legs used to retain a round bearing in certain end yoke designs.
Universal Joint	A device which can transmit torque and/or rotary motion from one shaft to another at fixed or varying angles of intersection of the shaft areas.
Wall Thickness	The measurement between the inside and outside diameter of a tube.
Weld Yoke	Same as tube yoke.
Wing Bearing	A member with a key and projecting wings used as the bearing base and positioning the thrust end of a cross trunnion.
Yoke Shaft	A one piece member designed to incorporate a tube yoke, tubing and stub shaft. It is used in close-couple applications and eliminates the need to use tubing.
Zerk	A lubrication fitting, usually threaded into a driveline component that will allow grease to be injected into the component, but does not allow grease to escape.



Off-Road / ATV / UTV



Commercial Vehicle



Industrial



Off-Highway-Ag

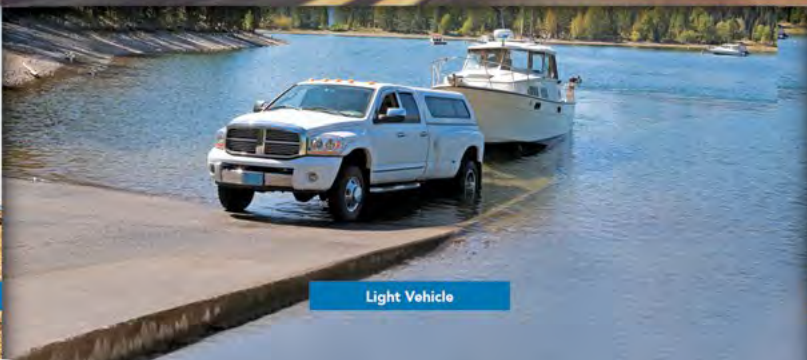

Light Vehicle



Performance

Notes



Off-Road / ATV / UTV



Commercial Vehicle



Industrial



Off-Highway-Ag

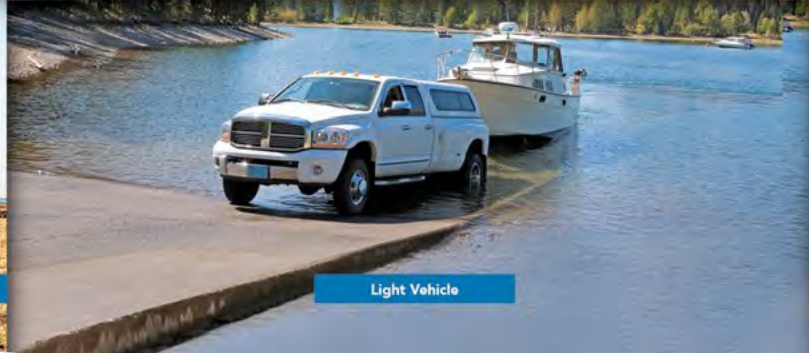

Light Vehicle



Performance

Notes



THE DRIVELINE EXPERTS

**THESE OE PLATFORMS TRUST NEAPCO.
YOU CAN TOO!**

I Q Z M S F I E S T A F O C U S A T
N J L O I X X E X P E D I T I O N J
S X W N E C O S P O R T Y U K O N V
I T S D R R A V I A T O R A N F T G
G D L E R J Y Y F F G D B C M V R A
N X D O A N A V I G A T O R E T A L
I S I L V E R A D O T D T V G S N A
A P B M U S T A N G J U Q K A K S X
S H E X P L O R E R H C B G N O I Y
X G M N E C O N O L I N E H E D T B
N X N J C O L O R A D O Q P N A A Y
A M U S T A N G S V T Y T N O N U Q

Find the following words in the puzzle.
Words are hidden → ↓ and ↘ .

AVIATOR
COLORADO
ECONOLINE
ECOSPORT
EXPEDITION
EXPLORER
F-150
FIESTA

FOCUS
GALAXY
INSIGNIA
MEGANE
MONDEO
MUSTANG
MUSTANG SVT
NAVIGATOR

SIERRA
SILVERADO
SKODA
TRANSIT
YUKON



THE DRIVELINE EXPERTS

**THESE OE PLATFORMS TRUST NEAPCO.
YOU CAN TOO!**

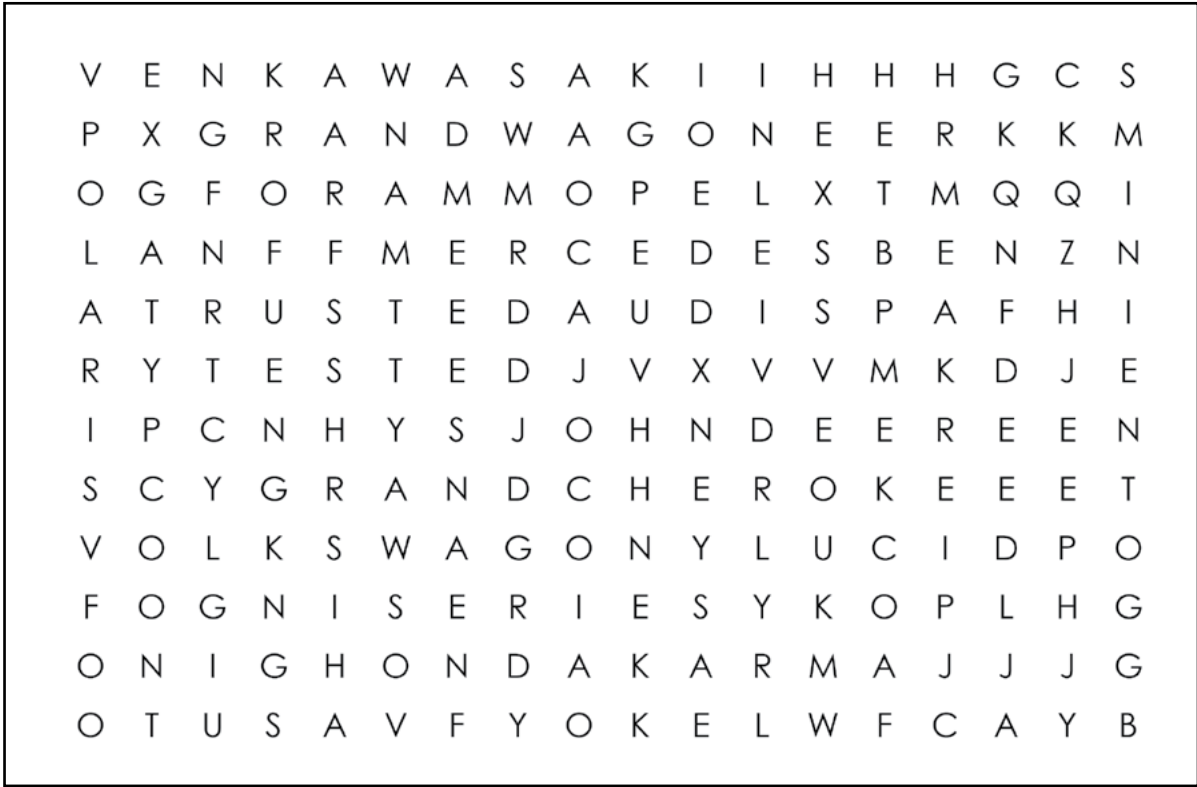

Find the following words in the puzzle.
Words are hidden → ↓ and ↘ .

- | | | |
|----------------|---------------|------------|
| AUDI | JOHN DEERE | RAM |
| CNH | KARMA | 3 SERIES |
| FCA | KAWASAKI | TESTED |
| GRAND CHEROKEE | LUCID | TOGG |
| GRAND WAGONEER | MERCEDES BENZ | TRUSTED |
| HONDA | MINI | USA |
| I20 | OPEL | VOLKSWAGON |
| JEEP | POLARIS | YOKE |

OEMs Trust Neapco for the First Installation.

OEMs around the world trust Neapco's quality, durability and performance for their vehicles as the original equipment installed at the factories.



You can trust us for the next installation.

You can trust Neapco's quality, durability and performance for all your aftermarket installations too.