

REVISION HISTORY		
REV.	DESCRIPTION	DATE
D	ADDED "CE" NOTE & CHANGED NONDISCLOSURE	1996-05-15
E	REPLACED SA950M2 PER CR# 1138	2003-05-15
F	CHANGED HOUSING PER P3# 03026	2003-09-05

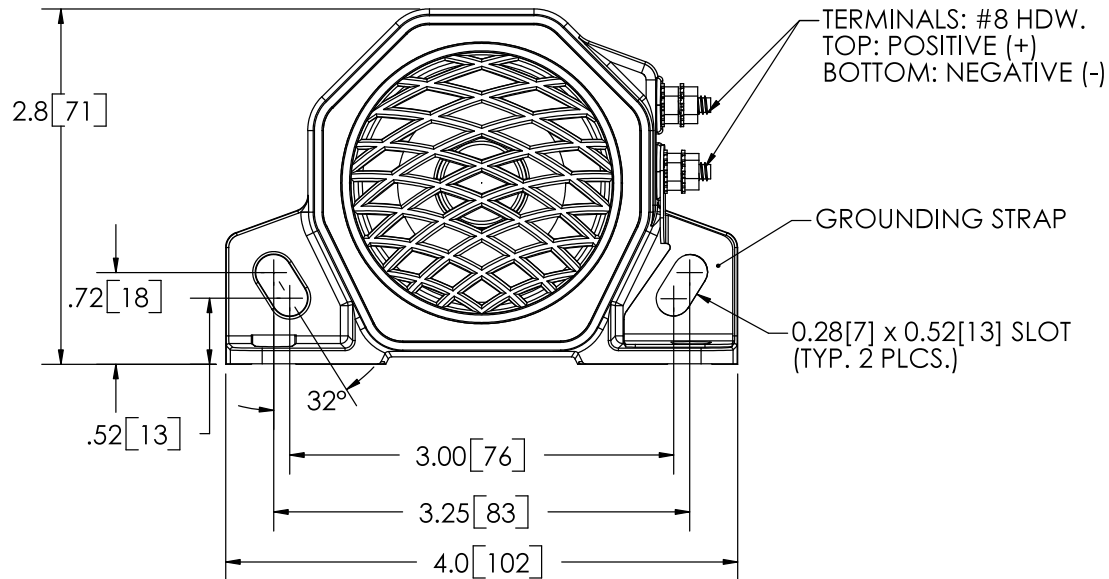

SPECIFICATIONS

- CERTIFICATIONS: **CE**; **UL**; e
- SOUND PRESSURE LEVEL: 82 to 102 ± 4 dB (A) @ 1.2m (4ft)
- VOLTAGE (NOMINAL): 12 to 24 VDC
- VOLTAGE (EXTREME): 10.5 to 32.0 VDC
- CURRENT (NOMINAL): 0.4 A
- POWER (NOMINAL): 9 W
- TEMPERATURE RANGE: -40°F (-40°C) TO 185°F (85°C)
- FREQUENCY: 960 to 1440 Hz
- CONNECTION: 8 - 32 UNI STUD CONNECTION
- RECOMMENDED MOUNTING: 1/4 - 20 UNC, GRADE 5 OR BETTER, 1/4" TYPE A, SERIES N OR W WASHER
- HOUSING MATERIAL: GLASS FILLED NYLON
- PRODUCT WEIGHT: 0.8 LBS

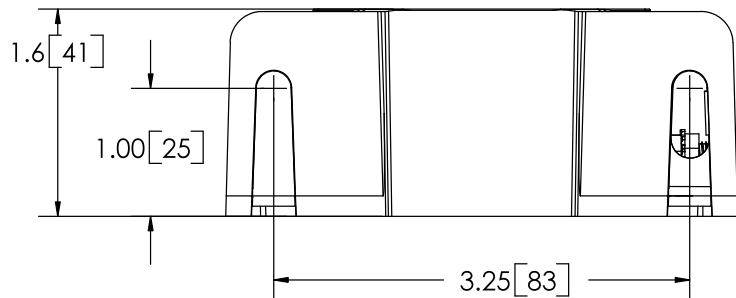

NOTES:
1. DIMENSIONS IN INCHES[MILLIMETERS]

NON DISCLOSURE AGREEMENT

THIS DRAWING AND THE DESIGN IT DISCLOSES ARE THE PRIVATE PROPERTY OF ECCO AND IS ISSUED IN CONFIDENCE FOR ENGINEERING INFORMATION ONLY. THE DRAWING AND / OR DESIGN MAY NOT BE USED, COPIED, REPRODUCED, OR OTHERWISE DISCLOSED IN PART OR AS A WHOLE TO OUTSIDERS OR USED FOR ANY OTHER PURPOSE WITHOUT THE PRIOR WRITTEN CONSENT OF ECCO. THE DRAWING IS SUBJECT TO RECALL AT ANY TIME. YOUR POSSESSION OF THIS DOCUMENT CONSTITUTES ACCEPTANCE OF THESE TERMS. © 2003 ECCO

CAD GENERATED DRAWING
DO NOT MANUALLY UPDATE.
MODEL REFERENCED:F

THIRD ANGLE PROJECTION

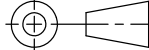

APPROVALS		DATE
DRAWN BY	RAM	
CHECKED		
ELEC. ENG.		
MECH. ENG.		
TEST ENG.		
SALES		

ECCO [®]		Electronic Controls Co. An Employee Owned Company 800-635-5900 P.O.BOX 7246,BOISE,ID 83707	
ALARM,SMART,82-102DBA,12-24VDC			
Project:		Date Created:1992-05-01	
SIZE	DWG. NO.	SA950	REV. F
SCALE 1:1.5	PREPARED PER ASME 14.100M-1998 / ASME Y14.1-1995	SHEET 1 OF 1	