



VIDEO INSTRUCTIONS

90150

# King Pin Press

## // Safety Warning

**Read all instructions and safety warnings prior to operation.**

**Failure to do so could result in equipment damage, personal injury, or even death.**

**CAUTION:** Use replacement parts and accessories provided by tiger tool only. All replacement parts and accessories are available. Keep hydraulic coupler protected when not in use. Dust caps should be used on couplers when not in use to avoid contaminants from entering the hydraulic cylinder and power source. This practice will help to extend the life of this product and ensure continued consistent operation.

- Stay Alert! Watch what you are doing and use common sense when operating this tool.
- Inspect product for damage prior to using; do not use if product is in unsafe condition.
- Do not operate tool while under the influence of drugs, alcohol, or medication.
- Always use safety equipment to prevent injuries. Approved face and eye protection must always be worn by the operator, as well as others in the work area.
- Do not overreach. Keep proper footing and balance at all times.
- Dress properly. Do not wear loose clothing or jewelry.
- Keep your hair, clothing and gloves away from moving parts.
- Keep hands clear of all pressurized hydraulic components.
- Always ensure hoses are free from sharp bends and kinks.
- Keep your work area clean and well lit.
- Cylinders are designed for 10,000 psi (700 bar) maximum working pressure. Do not connect to a pump with a higher rated pressure. Use a pressure gauge in the system at all times. Ensure all components in the system are rated for 10,000 psi (700 bar).

## Tiger Tool International Incorporated Warranty and Limit of Liability Terms and Conditions. For more information, visit [tigertool.com](http://tigertool.com)

**Warranties** - 1. Tiger Tool International Incorporated ("Tiger Tool") warrants to customers who purchase the tools from Tiger Tool or an authorized dealer of Tiger Tool that cast portions of the tools are free from defects in workmanship and materials at the time of sale and for as long as the original customer owns the tool pursuant to a contract of sale between the customer and Tiger Tool or its authorized dealer. 2. Tiger Tool warrants to its customers that threaded areas, bolts and machined components in or of the tools will not fail as a direct result of and caused solely due to defects in workmanship and materials not known at the time of purchase and not discovered by the purchaser or anyone on behalf of the purchaser for a period of two years from the date of original purchase. 3. Tiger Tool warrants to its customers that hydraulic components will not fail as a direct result of and caused solely by defects in workmanship and materials for a period of one year from the date of original purchase. 4. Tiger Tool makes no other warranty regarding the fitness for purpose, use, quality, merchantability, or functioning of the tools other than as stated in writing in these terms and conditions of warranty.

**Claims on Warranty** - 5. In order for Tiger Tool to assess any claim of warranty the customer of Tiger Tool agrees to deliver the tool to one of the addresses stated in paragraph 6 or such other place as Tiger Tool may designate, at the customer's sole expense such freight being fully pre-paid and insured by the customer to the addresses designated to the customer by Tiger Tool. 6. US returns: 115 first street PMB-T75520, Sumas, WA 98295, Canada returns: 160-34434 McConnell Road, Abbotsford, B.C., V2S 7P1

**Limit of Liability of Tiger Tool** - 7. The limit of liability of Tiger Tool for any claim of warranty made by any customer pursuant to these terms and conditions of warranty is that Tiger Tool may at its option, repair the tool, replace the tool or refund the purchase price for the tool to the customer. Tiger Tool is not liable for any damages or claims, monetary relief or any other damages or claims, including costs and legal costs except as set out in this paragraph. Tiger Tool is not liable for any economic loss, damages for bodily injury, or claims for property damages. The limit of the warranty and the liability of Tiger Tool to its customer is as set out in this warranty. The warranty does not extend into the secondary market and the limitation of liability set out in this warranty does extend into the secondary market for the tools of Tiger Tool. Tiger Tool is not responsible for any warranty of its tools to customers of its customer or those who otherwise come into possession or use of its tools through or by its original customer. Tiger Tool is not liable for any damages or claims, monetary relief or any other damages or claims, including costs and legal costs and Tiger Tool is not liable for any economic loss, damages for bodily injury, or claims for property damages to customers of its customer or those who otherwise come into possession or use of its tools through or by its original customer. 8. This warranty is null and void and is of no effect unless the tools purchased by the customer from Tiger Tool or its authorized representative are used in accordance with the terms and conditions of use and the instructions for use published by Tiger Tool in the instructions given with the tool and published on the website of Tiger Tool. 9. Tiger Tool does not warrant any of its tools that are subject to abnormal use, including without limitation misuse, accident, modification, unreasonable use, neglect, lack of maintenance or use after any portion of a tool is significantly worn. 10. In the case that Tiger Tool decides that the tools delivered to Tiger Tool pursuant to a claim made on this warranty do not meet the conditions for any liability of Tiger Tool to perform any obligation pursuant to this warranty, then the customer must at its own expense remove the tools from the premises of Tiger Tool. Tools that are subject to this paragraph and are rejected by Tiger Tool for any claim of warranty will be retained in Tiger Tool's warehouse facility for four months without any liability of Tiger Tool as a bailee or warehouse of the dealer or customer. These tools will be retained for pick up for four months in the warehouse of Tiger Tool at the sole risk of the dealer or customer, for insurance and loss howsoever caused including by the neglect of Tiger Tool or for anyone it is responsible. Tiger Tool will during the four month period make three attempts to contact the dealer or customer to pick up the tool, and after four months have expired from the first date that Tiger Tool gives notice to the dealer or customer that there is no valid warranty claim for the tools, then the dealer or customer agrees that Tiger Tool may dispose of the tools as it deems necessary, and the dealer or customer quit claims any property or other interest in the tools at the end of that four month period including any claim for refund of purchase price, loss or damage. 11. Without limiting anything in these terms and conditions of warranty, Tiger Tool shall not be liable for any indirect, consequential, exemplary, incidental, special or other similar damages incurred by a customer or any purchaser or user, or any person or entity who comes into possession of its tools, except for the warranties specifically between the customer and Tiger Tool as set out in paragraphs 1, 2 and 3 above. Tiger Tool is not in any case in any event in any circumstances whatsoever, liable for claims for lost profits, lost revenues, lost sales, lost business opportunities, lost or damaged goodwill, interruption of business or any other injury or damage to person or property howsoever connected to the possession or use of its tool(s). 12. The terms and conditions of warranties by Tiger Tool and the limits of liability as set out in these terms and conditions of warranty represent the sole and exclusive remedies of the customer and are in place of all other rights and remedies that the customer of Tiger Tool may have. 13. Tiger Tool reserves the right to change the design and construction of its tools at any time without any obligation to any customer who has purchased the tool or any user of the tool. Tiger Tool may in its sole discretion discontinue the sale or service of any tool at any time without obligation to any customer or user of the tool. 14. Any dispute, claim or other demand made by a customer or any party against Tiger Tool, arising out of this agreement, or regarding the sale, use, condition, or function of a tool sold by Tiger Tool shall be governed by the laws of British Columbia and such disputes, including any dispute brought by class or representative proceedings, shall be adjudicated in Vancouver, British Columbia by a sole arbitrator appointed pursuant to the provisions of the arbitration act R.S.B.C. 1996, C. 55, (As amended). Any party including any customer making any claim whatsoever against Tiger Tool arising of this warranty or otherwise hereby attorns to the jurisdiction of the province of British Columbia and agrees to the arbitration of those claims in Vancouver, British Columbia.



To make a return or to learn more about the Tiger Tool Return Policy, scan or visit [tigertool.com/policies/refund-policy](http://tigertool.com/policies/refund-policy)

U.S. Patent No.  
9511488

**TIGER TOOL**

Canada  
160-34434 McConnell Road,  
Abbotsford, BC V2S 7P1

USA  
115 First Street, PMB-T75520  
Sumas, WA 98295



**Did you know?**  
You can now call or text Technical Support.  
**1.800.661.4661**

# Operating Instructions

View the King Pin Press demonstration video online at [tigertool.com](http://tigertool.com)

**NOTE:** Hammering this tool will void your warranty.

VIDEO  
INSTRUCTIONS



## Using the 90150

**NOTE:** Both 1.25" diameter forcing screws share the same anvil.

**NOTE:** The 0.875 diameter forcing screw is designed for use with up to a 1/2" impact wrench. The 1.25" diameter forcing screw is designed for use with up to a 1" impact wrench.

- 1 Remove the hub
- 2 Remove the cotter pin and castle nut from the tie rod end and make sure tie rod end threads are clean and free of damage.
- 3 Select the corresponding sized Tie Rod End Remover. Thread on the tool until it bottoms out, then back it off one complete turn. **(Figure 1)**
- 4 Strike the top of the tool with a hammer, tie rod will "pop" loose. Remove the tool.
- 5 Remove the king pin wedge pins.
- 6 Place the Screw Plate (90150-21) over the king pin and insert two 5/8"x15" screws (90150-9) through the outer holes **(Figure 2)**. If the king pin is less than 1.25" in diameter, you'll need to swap the 1.25" threaded insert (90150-18) for the 0.875" threaded insert (90150-20) by removing the 5/16"-18 x 1/2" SHCS (90150-19). Tighten the 5/16"-18 x 1/2" SHCS by hand.
- 7 Position the Clearance Plate (90150-2) beneath the king pin and thread two 5/8"x15" screws (90150-9) into the outer holes **(Figure 3)**. For 2 1/2" king pins, use the Tiger Tool 90153 Clearance Plate. Visit [tigertool.com](http://tigertool.com) to purchase.

**NOTE:** If servicing an Isuzu NPR or GMC/Chevrolet W Series truck, use the Tiger Tool 90151 adapter (not included) in the bore of the clearance plate (90150-2). Visit [tigertool.com](http://tigertool.com) to purchase.

- 8 Install Tap Bolts (90150-10) into the torque arms with the hex heads facing the axle. Place the Torque Arms (90150-3) over the Clearance Plate (90150-2). Thread the inner two 5/8"x15" screws (90150-9) through the arms and into the Clearance Plate **(Figure 4)**. Hand tighten the Tap Bolts until the hex head touches the axle **(Figure 6)**. In some cases, you may not be able to use the Torque Arms. Be extra cautious when using the tool without them.



# Operating Instructions

- 9 Use an impact wrench to tighten all four 5/8"x15" screws (90150-9) until the Clearance Plate (90150-2) is snug against the bottom of the axle. Alternate tightening the four screws, ensuring the Clearance Plate and Screw Plate (90150-21) are parallel and concentric to the king pin (**Figure 5**).
- 10 Apply clean SAE 30 oil to the Forcing Screw and hand thread it into the Screw Plate (90150-21). If there is limited space above the tool, use the Forcing Screw - Short (90150-13) and transfer the 1.25" anvil (90150-16) from Forcing Screw (90150-4). Hand tighten until the Forcing Screw anvil touches the king pin.
- 11 Apply force to the Forcing Screw until the king pin falls through the bottom of the Clearance Plate (90150-2) (**Figure 7**).
- 12 Clean and lubricate the tool and put it back into the case.

## Preventative Maintenance

Keep forcing screw clean and lubricated at all times with SAE 30 lube for the threads.

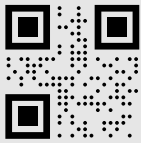
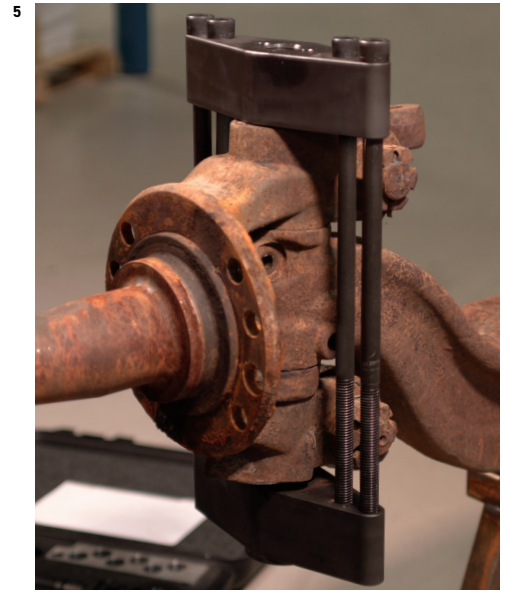

### Need some assistance with your Tiger Tool?

No worries! Scan this QR code with your phone to start texting with someone who can help out.

1.800.661.4661

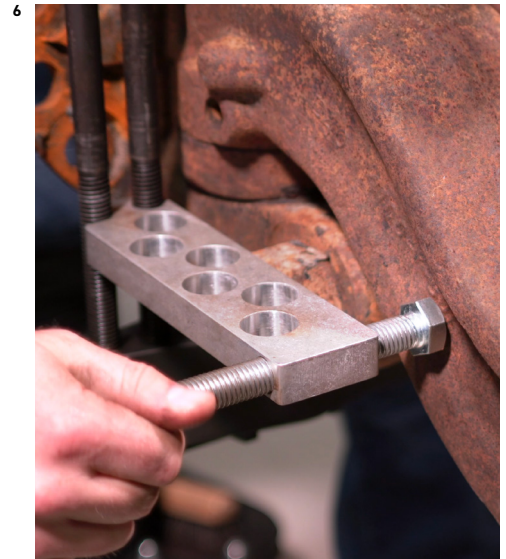

# Parts Breakdown

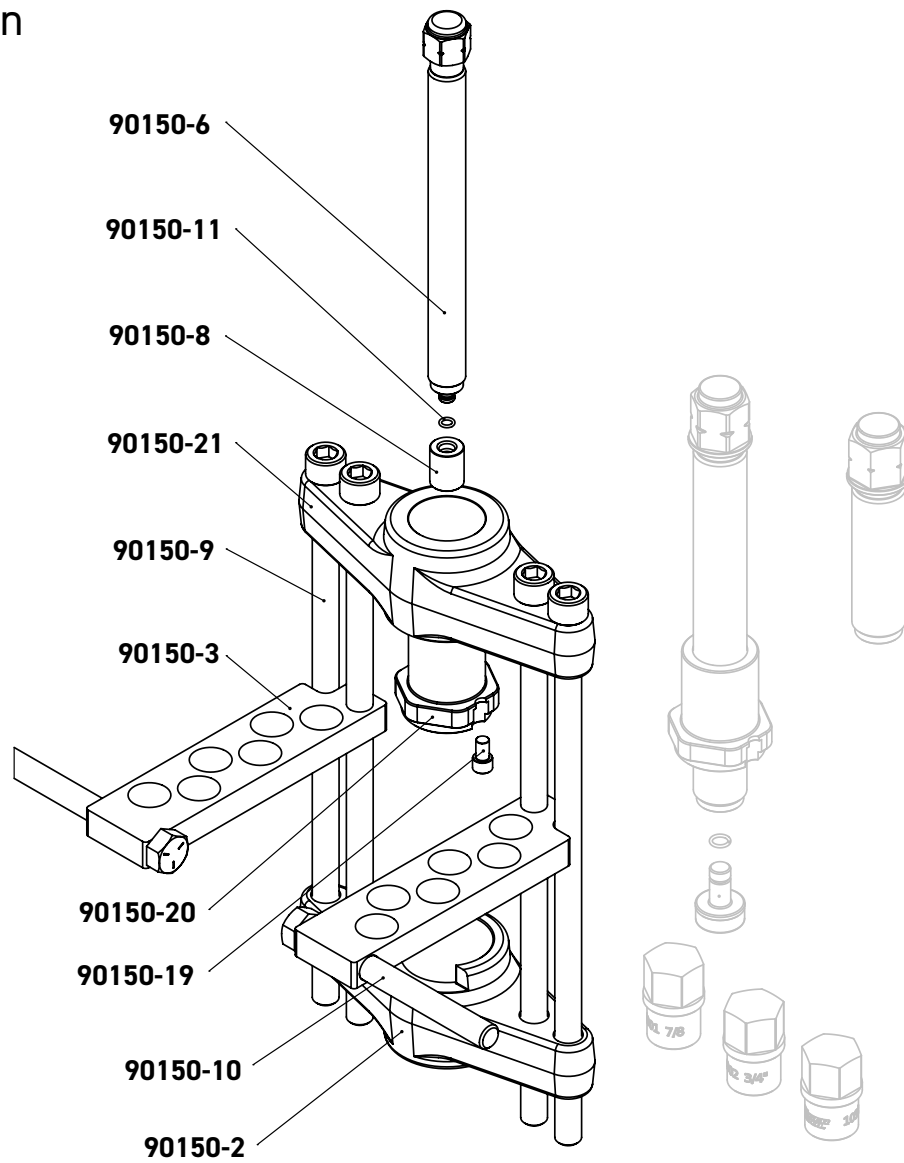

Part Number	Description	Qty.
90150-6	0.875" Forcing Screw	1
90150-11	O-Ring	1
90150-8	0.875" Anvil	1
90150-21	Screw Plate	1
90150-9	5/8"-11 X 15" SHCS	4
90150-3	Torque Arm	2
90150-20	0.875" Threaded Insert	1
90150-19	5/16"-18 X 1/2" SHCS	1
90150-10	5/8"-11 X 6" Tap Bolt	2
90150-2	Clearance Plate	1



# Parts Breakdown

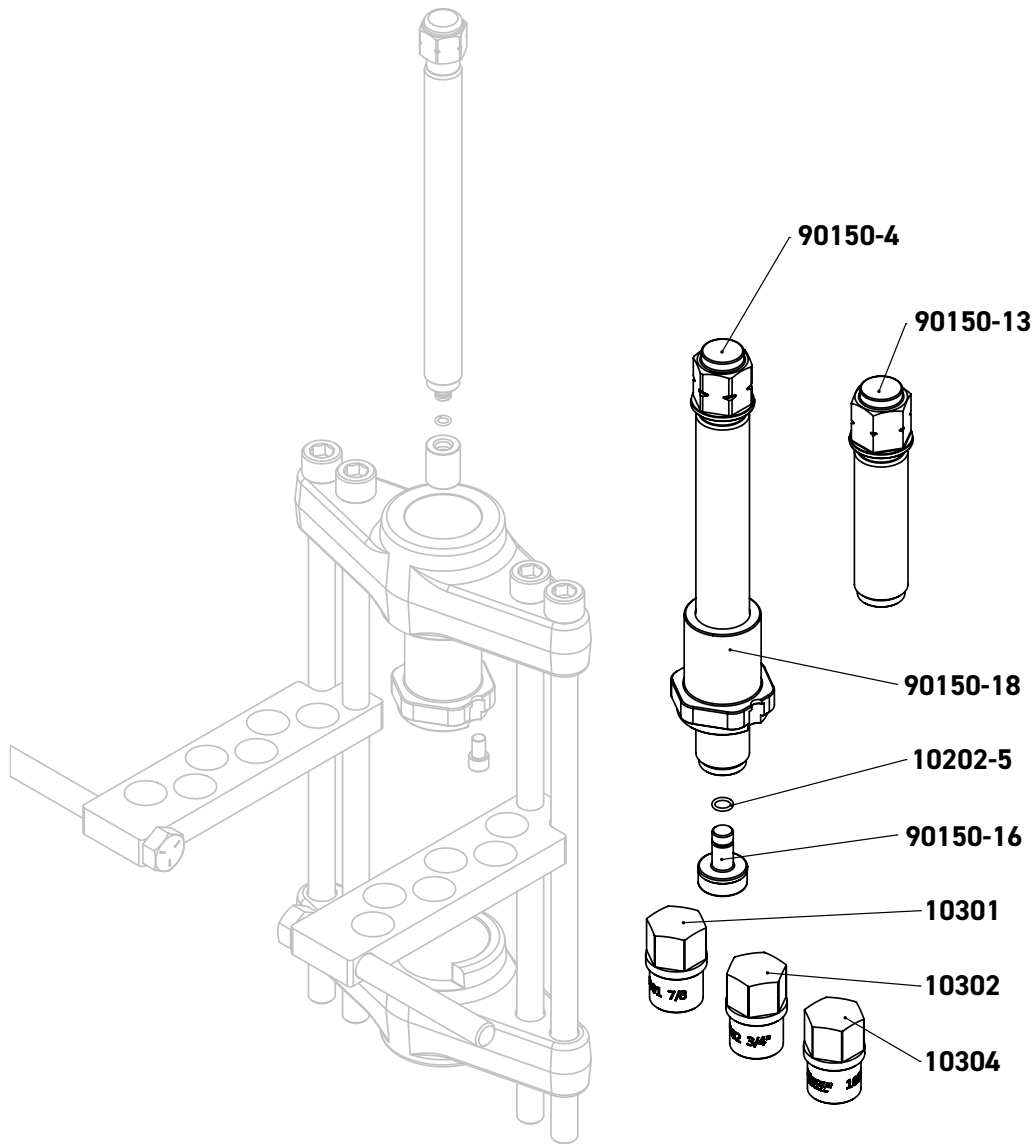

Part Number	Description	Qty.
90150-4	Forcing Screw	1
90150-13	Forcing Screw - Short	1
90150-18	1.25" Threaded Insert	1
10202-5	O-Ring	1
90150-16	1.25" Anvil	1
10301	Tie Rod End Remover - 7/8"-14 Unf	1
10302	Tie Rod End Remover - 3/4"-16 Unf	1
10304	Tie Rod End Remover - M20 X 1.5	1

